



**TILT-A WAY  
HYJG 1  
VERTICAL PIVOT GATE  
SINGLE PHASE VAC, THREE PHASE VAC  
AND 24 VDC**

**Vehicle Class  
I, II, III, and IV  
Operators & Parts Manual**



**NOTE: WHEN ORDERING PARTS, PLEASE HAVE YOUR SERIAL NUMBER  
TO ENSURE THE CORRECT PARTS ARE SENT TO YOU.**

**Manual subject to change with out notice.**

**Ideal Manufacturing, Inc. • 2011 Harnish Blvd. • Billings, MT 59101  
P (406) 656-4360 • F (406) 656-4363**

# GROUP 27 BATTERY

600 COLD CRANKING AMPS

160 MIN RESERVE CAPACITY

TABLE OF CONTENTS

DESCRIPTION	PAGE #
WARRANTY	
SAFETY INFORMATION / CLASS OF VEHICULAR GATE / PROTECTION AGAINST ENTRAPMENT	1
GATE SPECIFICATIONS	2
ALTERNATE FENCE SCHEMES	3
GENERAL INFORMATION	4
USER INTERFACE BOARD GENERAL INFORMATION	5
LOGIC BOARD GENERAL INFORMATION	6
MOTOR CONTROL BOARD GENERAL INFORMATION	7
ELECTRICAL DIAGRAM 24 VOLT DC	8, 9
MASTER GATE ELECTRICAL DIAGRAM 24 VOLT DC	10
SLAVE GATE ELECTRICAL DIAGRAM 24 VOLT DC	11
ELECTRICAL DIAGRAM SINGLE PHASE 208 / 240 VAC	12,13
MASTER GATE ELECTRICAL DIAGRAM SINGLE PHASE 208 / 240 VAC	14
SLAVE GATE ELECTRICAL DIAGRAM SINGLE PHASE 208 / 240 VAC	15
ELECTRICAL DIAGRAM THREE PHASE 208 / 240 VAC	16, 17
MASTER GATE ELECTRICAL DIAGRAM THREE PHASE 208 / 240 VAC	18
SLAVE GATE ELECTRICAL DIAGRAM THREE PHASE 208 / 240 VAC	19
ELECTRICAL DIAGRAM THREE PHASE 480 VAC	20,21
MASTER GATE ELECTRICAL DIAGRAM THREE PHASE 480 VAC	22
SLAVE GATE ELECTRICAL DIAGRAM THREE PHASE 480 VAC	23
REFLECTIVE TYPE PHOTO EYE DIAGRAM	24
SAFETY WARNING LIGHT DIAGRAM	25
ELECTROMAGNETIC LOCK	26
EMERGENCY STOP DIAGRAM 24 VDC	27
EMERGENCY STOP DIAGRAM SINGLE PHASE 208 / 240 VAC	28
EMERGENCY STOP DIAGRAM THREE PHASE 208 / 240 VAC	29
EMERGENCY STOP DIAGRAM THREE PHASE 480 VAC	30
MANUAL KEY SWITCH DIAGRAM	31
GATE OPEN INDICATOR LIGHT DIAGRAM 24 VDC	32
GATE OPEN INDICATOR LIGHT DIAGRAM SINGLE PHASE 208 / 240 VAC	33
GATE OPEN INDICATOR LIGHT DIAGRAM THREE PHASE 208 / 240 VAC	34
GATE OPEN INDICATOR LIGHT DIAGRAM THREE PHASE 480 VAC	35
SIREN OPERATED SENSOR DIAGRAM	36
SIREN OPERATED SENSOR INSTRUCTIONS	37, 38
ELECTRICAL LOOP LAYOUT	39
LOOP DETECTOR OPERATING INSTRUCTIONS	40, 51
LOOP DETECTOR SOCKET DIAGRAM	52
RADIO RECEIVER DIAGRAM THREE BUTTON	53
RADIO RECEIVER DIAGRAM SINGLE BUTTON	54
RADIO RECEIVER INSTRUCTIONS	55, 62
REMOTE CONTROL STATION PEDESTAL	63
MONITORED REVERSING EDGE INSTALLATION	64
STANDARD REVERSING EDGE INSTALLATION	65
CONTROL BOARD PROGRAM MENU	66,71
BLANK PAGE FOR NOTES	
OPERATOR ENCLOSURE	72
PROPORTIONAL VALVE SETTINGS	73
PROPORTIONAL VALVE DIAGRAM	74
COLD WEATHER PACKAGE 24 VDC	75
COLD WEATHER PACKAGE SINGLE PHASE 208 / 240 VAC	76
COLD WEATHER PACKAGE THREE PHASE 208 / 240 VAC AND 460 / 480 VAC	77
BARRIER UNIT	78
OPERATOR FIELD INSTALLATION FOR ASSEMBLED GATE	79, 80
OPERATOR FIELD INSTALLATION FOR UNASSEMBLED GATE	79, 80
BALANCE SYSTEM ADJUSTMENT AND SAFETY WARNINGS	81, 82
SPRING, CABLE, AND SHEAVE REPLACEMENT	83, 84
GENERAL ARRANGEMENT & GENERAL MAINTENANCE	85, 86
BARRIER CARRIAGE – SHORT & STANDARD	87, 88

ACTUATOR CYLINDER WITH COMPONENTS	89, 90
OMRON REFLECTIVE TYPE PHOTOEYE	91
BATTERY LOCATION 24 VOLT DC OPERATOR ONLY	92
BALANCE SYSTEM CABLE GUIDE	93
BALANCE SYSTEM – CABLE, SHEAVE & OPTIONAL ICE SCRAPER	94
BARRIER END STANCHION - PHOTO EYE / SURFACE MOUNT STANCHION - PHOTO EYE	95
MAGLOCK MOUNTING	96
BALANCE SYSTEM SPRING TENSIONER UNIT	97, 98
HYDRAULIC SYSTEM	99, 100
CUSTOM HYDRAULIC POWER UNIT	101, 102
TROUBLE SHOOTING GUIDE	103, 105
CAUTIONS AND WARNINGS IN FRENCH	END



Tilt-A-Way

HYJG 1

Serial Number \_\_\_\_\_

Barrier Size \_\_\_\_\_ Long \_\_\_\_\_ Tall

Barrier Type \_\_\_\_\_

Notes:



**2011 Harnish Blvd.  
Billings, MT 59101**

---

**INFO@TILTAWAY.COM  
406-656-4360 800-523-3888**

## **Ideal Mfg., Inc. - Tilt-A-Way Limited Warranty**

Ideal Manufacturing, Inc. ("Ideal") warrants that, at the time of sale, this Tilt-A-Way vertical pivot gate ("product") will, in all material respects, conform to its applicable specification and will be free from defects in material and manufacture. This warranty does not extend to electrical components, nor does it extend to products or components not manufactured by Ideal. Ideal disclaims all warranties for such products or components, which carry only the original warranty, if any, of their original manufacturer. Ideal designates its rights under such manufacturer warranties to buyer.

Ideal further warrants that the product will, with recommended maintenance and without being subjected to extraordinary or abnormal use or abuse, remain functional under this warranty for 3 years, which begins on the date of purchase.

**Any modification or alteration made to the product will void the warranty unless it is approved in writing by Ideal, and in advance of the change.** This exclusion does not apply to normal installation of approved accessories and/or safety devices. This warranty shall not apply to equipment that has been (1) improperly installed or installed inconsistent to instructions; (2) subjected to negligence, accident, vandalism, or damaged by severe weather, wind, flood, fire, or war; or (3) damaged through improper operation, maintenance, storage or abnormal use or abuse. **The proper operation of this product is dependent on your compliance with the instructions regarding installation, operation, maintenance and testing. The warranty does not cover damage(s) or defects resulting from the failure to comply strictly with those instructions.**

This warranty is exclusive and is the only warranty given by Ideal and is in place of all others. This warranty supersedes any prior, contrary or additional representations, whether oral, written, expressed or implied. In no event shall Ideal be liable or responsible for incidental or consequential damage or for any other direct or indirect damage loss, cost, expense or fee.

This warranty does not cover or extend to any incidental expenses for replacement of consumables (batteries, oil, grease, etc.), including labor, shipping, travel time, standby time, or loss of use that are incurred.

If the product fails to conform to the warranty parameters, the buyer must notify Ideal within a reasonable time and in no event more than thirty (30) days after the discovery of the nonconformity. Ideal will investigate and, in the event of an entitled warranty claim, will provide, at its option and

within a reasonable period of time, repair or replacement of any nonconforming products or components. Replacement products or components will conform to this warranty for the unexpired duration of the warranty period for the original, nonconforming product or component. Ideal reserves the right to supply used, reconditioned or repaired material for all warranty claims. This warranty does not cover or extend to any incidental expenses, including labor, shipping, travel time, standby time, or loss of use that are incurred for inspection or replacement of any nonconforming products or components.

In most cases replacement products or components will be handled as an advanced return scenario. This type of return is used when Ideal provides an advanced replacement of a suspect warranty part before the suspect part has been returned to Ideal. An invoice for the product or component cost and outgoing freight will be issued to the buyer. **Credit for the replacement product or component and shipping costs will be issued only after the suspect product or component has been returned to Ideal, inspected and approved as defective. Suspect products or components must be returned to Ideal no later than 60 days from the date the advanced replacement is shipped out to the buyer.** Replacement products or components will be shipped standard ground freight. If expedited shipping is required, the buyer will be responsible for any increase in shipping costs.

This warranty gives you specific legal rights. You may also have other rights which vary from state to state or province to province.

Contact Ideal Manufacturing Inc. for additional information and/or instructions about Ideal's warranty or warranty claim process.

I, as the buyer, acknowledge that I have reviewed and understand this, Tilt-A-Way Limited Warranty.

\_\_\_\_\_  
Signature

\_\_\_\_\_  
Date

## IMPORTANT SAFETY INFORMATION

**Before installing the installer should read and understand the owners manual and safety instructions. The owner should read, and keep this owners manual. Read and Follow All Instructions.**

### **WARNING-TO REDUCE THE RISK OF INJURY OR DEATH TO PERSONS**

1. Do not operate gate unless all safety devices are connected and working properly.
2. The gate must be properly installed and work freely in both directions prior to the installation of the gate operator. Do not adjust pressure relief valve to compensate for an improperly installed, improperly functioning, or damaged gate.
3. Do not permit children to play on or around a gate. Keep all controls out of reach from children.
4. Automatic gates are not intended for pedestrian use. Pedestrians must be supplied a separate entrance separate from the automatic gate.
5. Never operate an automatic gate system without visual contact so it can be shut down if necessary.
6. Permanently mounted controls intended for user activation must be located at least 6 feet away from the gate and operator.
7. Disconnect all power before performing any maintenance on your gate or operator.
8. Keep your gate properly maintained-have a qualified service person make all repairs.
9. A qualified technician should test your gate monthly. The gate MUST reverse on contact with a rigid object. After adjusting the force of the limit of travel, retest the gate operator. Failure to adjust and retest the gate operator properly can increase the risk of injury or death.
10. The gate and operator must have two appropriate safety devices to match the gate class installation. Type A – inherent, and Type B2- Contact sensor.
11. Operator and barrier must display warning signs on both sides, in view of operator.
12. Do not install added weight to the gate barrier, your barrier has been balanced at the factory, if you add weight to the barrier it will make your gate out of balance, which could cause it to malfunction.
13. Before turning the power on make sure that the correct voltage has been supplied to the electric motor and the equipment has been properly grounded.
14. Always keep people and objects away from the gate. NO ONE SHOULD CROSS THE PATH OF THE MOVING GATE.
15. Only qualified personnel should install this equipment. Failure to meet this requirement could cause severe injury and or death, for which the manufacturer cannot be held responsible.

## CLASS OF VEHICULAR GATES

### Glossary

#### **CLASS I-RESIDENTIAL VEHICULAR GATE OPERATOR (3.19)**

A vehicular gate operator (or system) intended for use in garages or parking areas associated with a residence of one to four single families.

#### **CLASS II-COMMERCIAL/GENERAL ACCESS VEHICULAR GATE OPERATOR (3.4)**

A vehicular gate operator (or system) intended for use in a commercial location or building such as multi-family housing unit (five or more single family unit), hotel, garages, retail store, or other buildings accessible by of servicing the general public.

#### **CLASS III-INDUSTRIAL/LIMITED ACCESS VEHICULAR GATE OPERATOR (3.11)**

A vehicular gate operator (or system) intended for use in an industrial location or building such as a factory or loading dock area or other locations not accessible by or intended to service the general public.

#### **CLASS IV-RESTRICTED ACCESS VEHICULAR GATE OPERATOR (3.20)**

A vehicular gate operator (or system) intended for use in a guarded industrial location or building such as an airport security area or other restricted access locations not servicing the general public, in which unauthorized access is prevented via supervision by security personal.

## INSTRUCTIONS FOR MANUAL OPERATION TILT-A-WAY MODEL HYJG

**Note: Use the manual operation only when the gate is not moving and with the power turned off**

1. *Locate two Brass colored knurled knobs on the top of the pump housing*
2. *(If equipped with a cold weather package, lift flap on the black cover to access knobs.)*
3. *Turn both knobs counter clockwise one full turn to open.*
4. *Gate barrier can now be lifted manually from out at the end of gate.*
5. *Turn knobs clockwise to close, then operate gate normally.*

## PROTECTION AGAINST ENTRAPMENT

Gate operator category	
Horizontal slide, vertical lift, and vertical pivot	Swing and vertical barrier (arm)
Entrapment protection types (a)	Entrapment protection types (a)
A, B1, B2, or D	A, B1, B2, C, OR D
<p>Note-The same type of device shall not be utilized for both entrapment protection means. Use of a single device to cover both the opening and closing directions is in accordance with the requirement; however, a single device is not required to cover both directions. A combination of one Type B1 for one direction and one Type B2 for the other direction is the equivalent of one device for the purpose of complying with the requirements of either entrapment protection means.</p> <p>(a) Entrapment protection types:                      Type A – Inherent entrapment protection system. See 31.1.5.                      Type B1 –Non-contact sensor (photoelectric sensor or the equivalent). See 31.1.6 – 31.1.9.                      Type B2 –Contact sensor (edge device or the equivalent). See 31.1.7 and 31.1.11 – 31.1.13.                      Type C – Inherent force limiting, inherent adjustable clutch or inherent pressure relief device. See 31.1.15 and 31.2.1.2 (b).                      Type D –Actuating device requiring continuous pressure to maintain opening or closing motion of the gate. See 31.1.16 and 31.1.17.</p>	

## Specifications

<b>Model#</b>		<b>HYJG 1</b>		
<b>Operator Size</b>		<b>28" W x 50" T x 120"L</b>		
<b>Operator Weight</b>		<b>1,800 lbs.</b>		
<b>Maximum Barrier Size</b>		<b>375 lbs</b>		
<b>Voltage</b>	<b>Phase</b>	<b>Hz</b>	<b>Cir. Reg. Amps.</b>	<b>Act. Draw</b>
208/240 VAC	1	60	20	14
208/240 VAC	3	60	10	9
480 VAC	3	60	5	3
<b>Control Board Voltage</b>				
24 VDC				
<b>For 24 VDC motor operator</b>				
<b>Voltage</b>	<b>Hz</b>	<b>Cir. Reg. Amps.</b>		
120 VAC	60	15	(for battery charger and accessories)	
<b>Motor Voltage</b>		<b>Control Board Voltage</b>		
24 VDC		24 VDC		
<b>Operator Speed to 90*</b>			<b>16-20 Seconds</b>	
<b>Hydraulic Fluid</b>			<b>Citgo-CP (this hydraulic fluid is blue in color)</b>	
<b>Maximum Operating Temperature</b>			<b>70 C / 158 F</b>	

**Note: Hydraulic pump pressure factor set at 385 PSI do not exceed this setting**

**Note: Wire size is very important. Measure the distance from your power source to the gate operator location. For wire sizes consult the NEC (National Electric Code).**

### Recommended Wire Size

**208/240 VAC AMPS 20 SINGLE PHASE**

Length of circuit in feet

20'-60' 60'-100' 100'-160' 160'-240' for circuit length greater than 240' consult a licensed electrician

Wire size 12      10      8      6

**208/240 VAC AMPS 10 THREE PHASE**

Length of circuit in feet

20'-120' 120'-180' 180'-300' 300'-480' 480'-760' 760'-1220' 1220'-1540' 1540'-1940' 1940'-2440'

Wire size 14      12      10      8      6      4      3      2      1

**460/480 VAC AMPS 5 THREE PHASE**

Length of circuit in feet

20'-500' 500'-800' 800'-1280' 1280'-2040' 2040-3260' 3260'-5200' 5200'-8240'

Wire size 14      12      10      8      6      4      3

**120 VAC AMPS 15**

Length of circuit in feet

20'-60' 60'-100' 100'-160' 160'-280' for circuit length greater than 260' consult a licensed electrician

Wire size 12      10      8      6

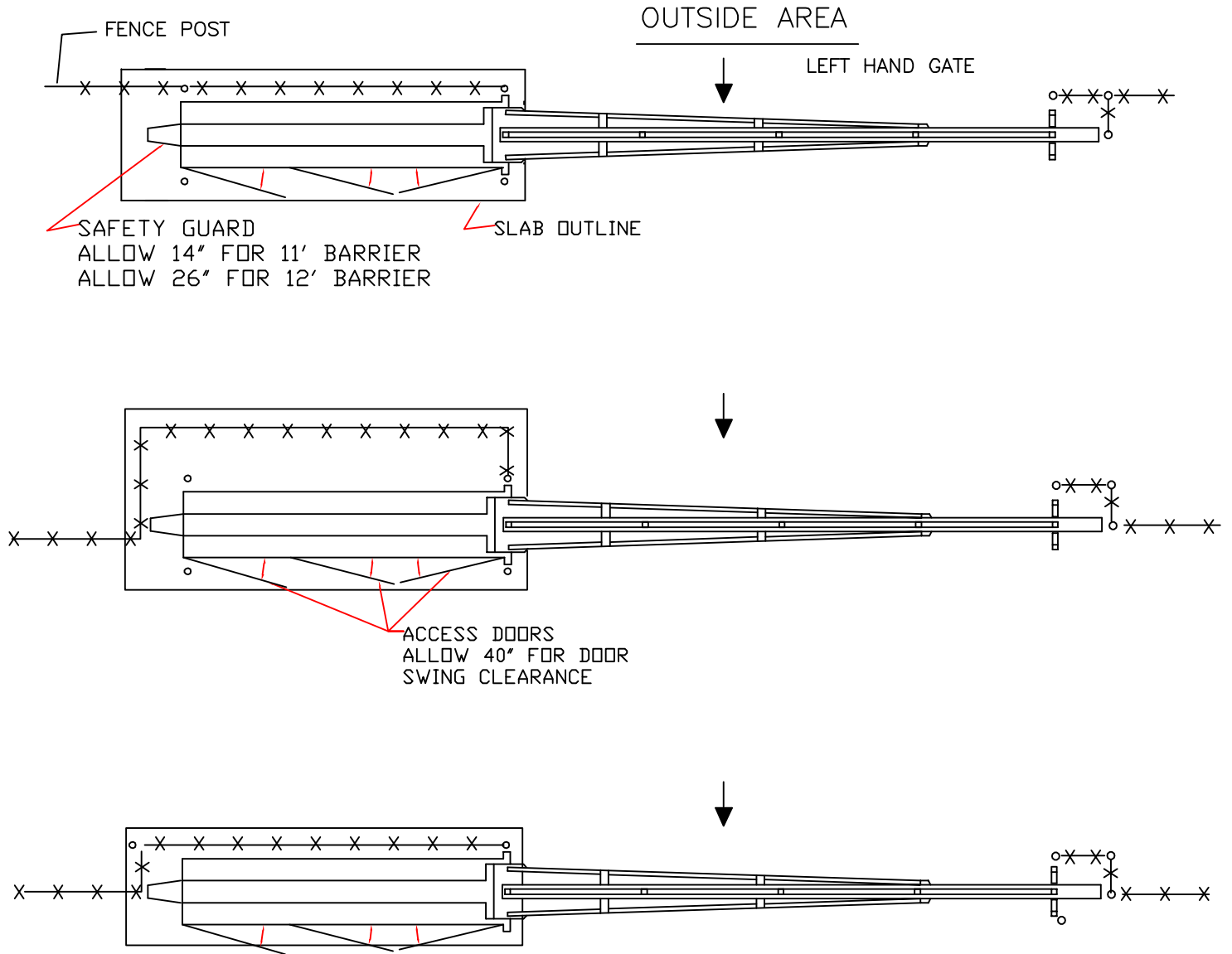

INDICATED ARE THREE MOST COMMON WAYS TO SET A TILT-A-WAY GATE  
INDIVIDUAL CONDITIONS MAY REQUIRE A SPECIAL ARRANGEMENT

### ALTERNATE FENCE SCHEMES HYJG 1

# Tilt-A-Way HYJG 1

## GENERAL INFORMATION

Tilt-A-Way HYJG vertical pivot gate operates on various voltages. They are 240-vac single phase, 240-vac three phase, 480-vac three phase, or 24-vdc. If the gate operates on 24-vdc it will need two 12-vdc batteries (batteries not included). We recommend two 12-volt dc maintenance free lead acid deep cycle series 27 battery 85 amp hours or equivalent. The two 12-volt batteries are wired in series to supply 24 volts to the control boards. The wiring harness is equipped with ring terminals designed to connect to bolt type battery post (red wire to positive and black wire to negative). See wiring diagram on page 9 of this manual. Do not reverse battery polarity at the battery or circuit board. Severe damage will occur. Disconnect the battery and all power sources before installing any devices. Do not perform any welding while the motor cable is connected to the control board or the battery connected. Serious damage to the control board and battery will occur.

Caution – Risk of explosion if battery is replaced by an incorrect type.

Dispose of used batteries according to the batteries manufactures instructions.

Tilt-A-Way HYJG vertical pivot gate has a programmable control board, which allows numerous programmable functions in various combinations (see programming section at in this manual). The control board has Position Feedback. If the gate reverses direction twice and stops because of the Position Feedback the control board will have to be UL reset.

A battery charger is supplied to keep the batteries charged on the 24-vdc model. See charger owner's manual for proper operation.

A qualified technician should check, and adjust all safeties monthly. The balance of the barrier should also be checked, and adjusted monthly by a qualified technician.

Tilt-A-Way HYJG vertical pivot gate is supplied with two entrapment protection devices. Type A, inherent entrapment protection system, manufacturer by Polytron on the logic control board part number PEO202L. Type B2, contact-sensor edge, manufacturer by ASO Safety Solutions, model 25.30. Both of the entrapment protection devices must be connected and functioning properly before the gate operator is put into service. This is the maximum number of entrapment protection devices to be connected to the operator.

Tilt-A-Way HYJG vertical pivot gate must be installed in a location so that enough clearance is supplied between the gate and adjacent structures when opening and closing to reduce the risk of entrapment.

TILT-A-WAY  
HYJG 1  
USER INTERFACE BOARD

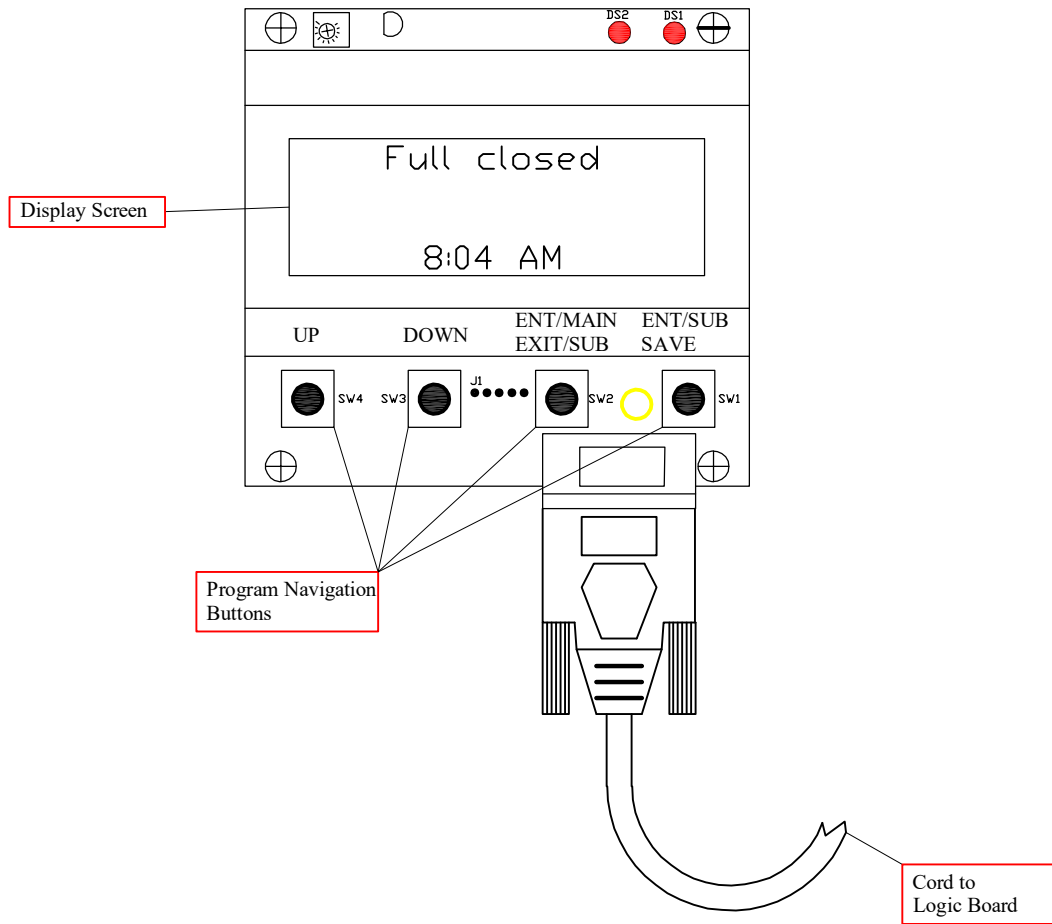

TILT-A-WAY  
INTERFACE BOARD

The interface board has many functions for the end user to access. The four push buttons on the board are used to navigate the programming. Push and hold button SW2 for about 4 seconds to enter the main program menu. When in the program menu push and release button SW2 to exit main menu, or sub menus. Button SW4 will scroll up in the menus, and adjustable settings in sub menus. Button SW3 will scroll down in the menus, and adjustable settings in sub menus. Button SW1 will enter into menus, and sub menus. When in sub menus, and after changing adjustable setting the SW1 button will save the change when pushed. The interface does not have to be connected to the Logic Board for the gate to open or close. See program section of this manual for full program menus.





TILT-A-WAY  
HYJG 1 MOTOR CONTROL BOARD

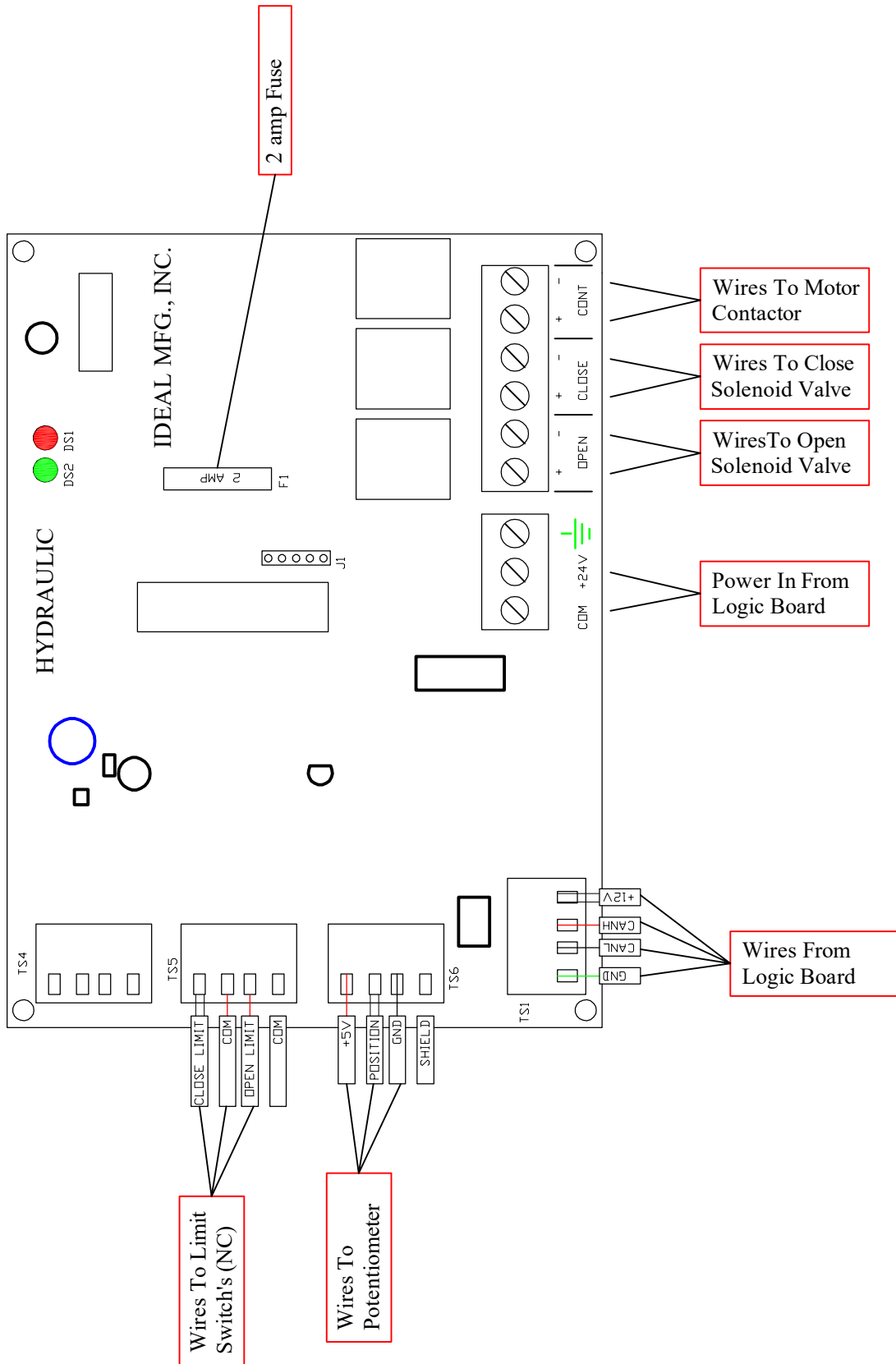

**TILT-A-WAY HYJG 1  
 BASIC ELECTRICAL HARDWARE 24-VDC  
 DRAWING HYJG-204 ON PAGE 9 SINGLE GATE  
 DRAWING HYJG-205 ON PAGE 10 MASTER GATE**

REF	PART NO.	DESCRIPTION	QTY
1	PEO961	ENCLOSURE	1
2	PEO670	CIRCUIT BREAKER (15 AMP)	1
3	PEO671	CIRCUIT BREAKER (40 AMP)	1
4	PEO202I	INTERFACE BOARD	1
5	PEO202L	LOGIC BOARD	1
6	PEO202H	MOTOR BOARD	1
7	PEO202C	CONNECTING CORD	1
8	PEO611	SAFETY SWITCH	2
9	PEO963A	LIMIT SWITCH (nc)	4
10	100234-1	POTENTIOMETER	1
11	PEO223	½" ROMEX	3
12	PEO275	¾" ROMEX	3
13	100127	ALARM	1
14	TWO448	BATTERY CHARGER (24 VOLT)	1
15	PEO605A	RELAY SOCKET 5 PIN	1
16	PEO679	RELAY 5 PIN SAFETY	1
17	PEO620	END BARRIER (not shown)	1
18	PEO621	GREEN TERMINAL BLOCK	1
19	PEO622	BLACK TERMINAL BLOCK	3
20	PEO623	RED TERMINAL BLOCK	3
21	PEO665	RADIO RECEIVER (optional not shown)	1
22	PEO663	RADIO TRANSMITTER (optional not shown)	as req.
23	PEO674	POWER CONTACTOR	1
24	100133	DIODE	1

**DRAWING HYJG-206 ON PAGE 11 SLAVE GATE**

REF	PART NO.	DESCRIPTION	QTY
1	PEO292	ENCLOSURE	1
2	PEO670	CIRCUIT BREAKER (15 AMP)	1
3	PEO671	CIRCUIT BREAKER (40 AMP)	1
5	PEO202H	MOTOR BOARD	1
8	PEO611	SAFETY SWITCH	2
9	PEO963A	LIMIT SWITCH (nc)	4
10	100234-1	POTENTIOMETER	1
11	PEO223	½" ROMEX	3
12	PEO275	¾" ROMEX	3
14	TWO448	BATTERY CHARGER (24 VOLT)	1
15	PEO605A	RELAY SOCKET 5 PIN	1
16	PEO679	RELAY 5 PIN SAFETY	1
17	PEO620	END BARRIER (not shown)	1
18	PEO621	GREEN TERMINAL BLOCK	1
19	PEO622	BLACK TERMINAL BLOCK	3
20	PEO623	RED TERMINAL BLOCK	3
23	PEO674	POWER CONTACTOR	1
24	100133	DIODE	1

# TILT-A-WAY HYJG 1 SINGLE GATE 24 VOLT DC

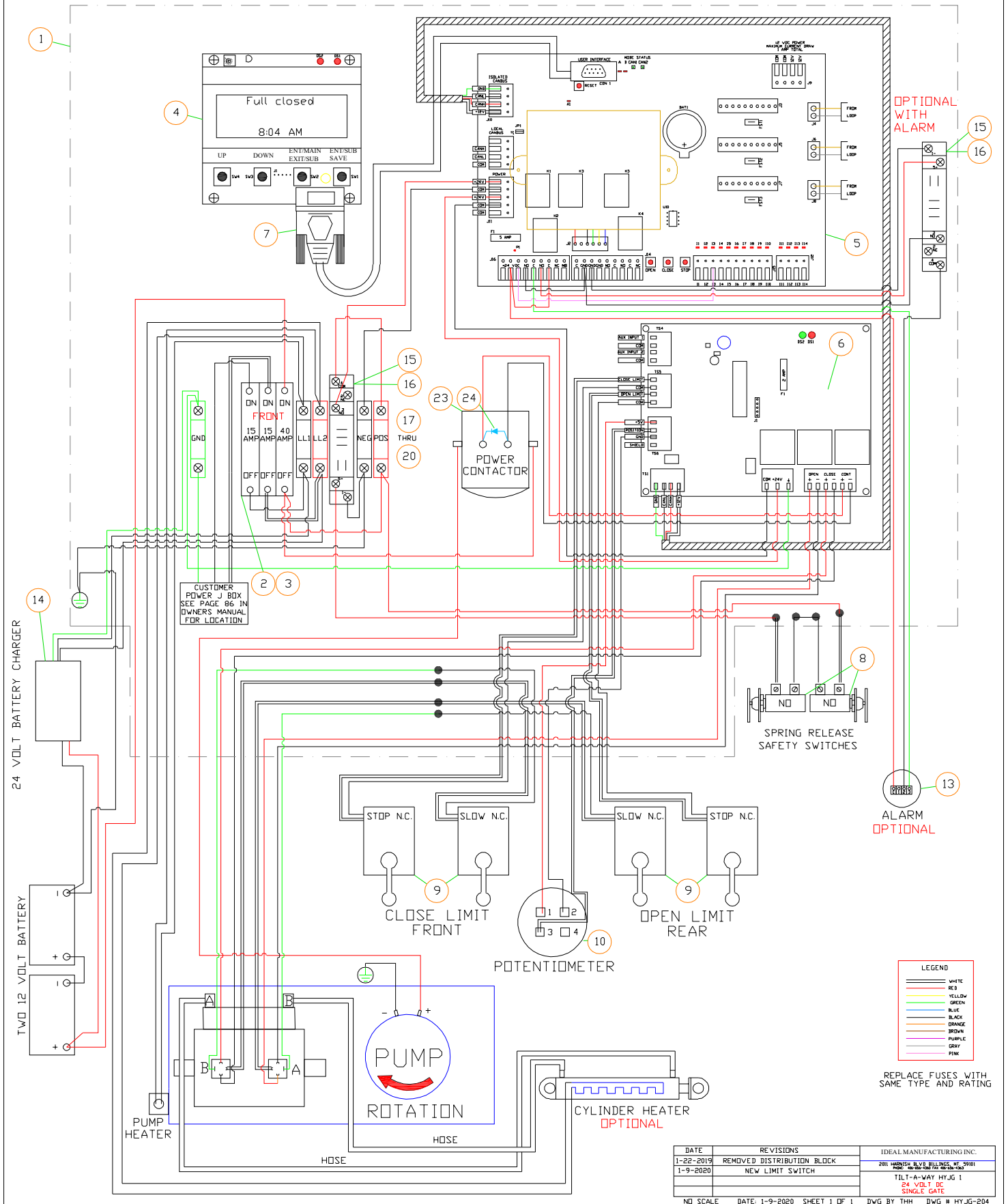

# TILT-A-WAY HYJG 1 MASTER GATE 24 VOLT DC

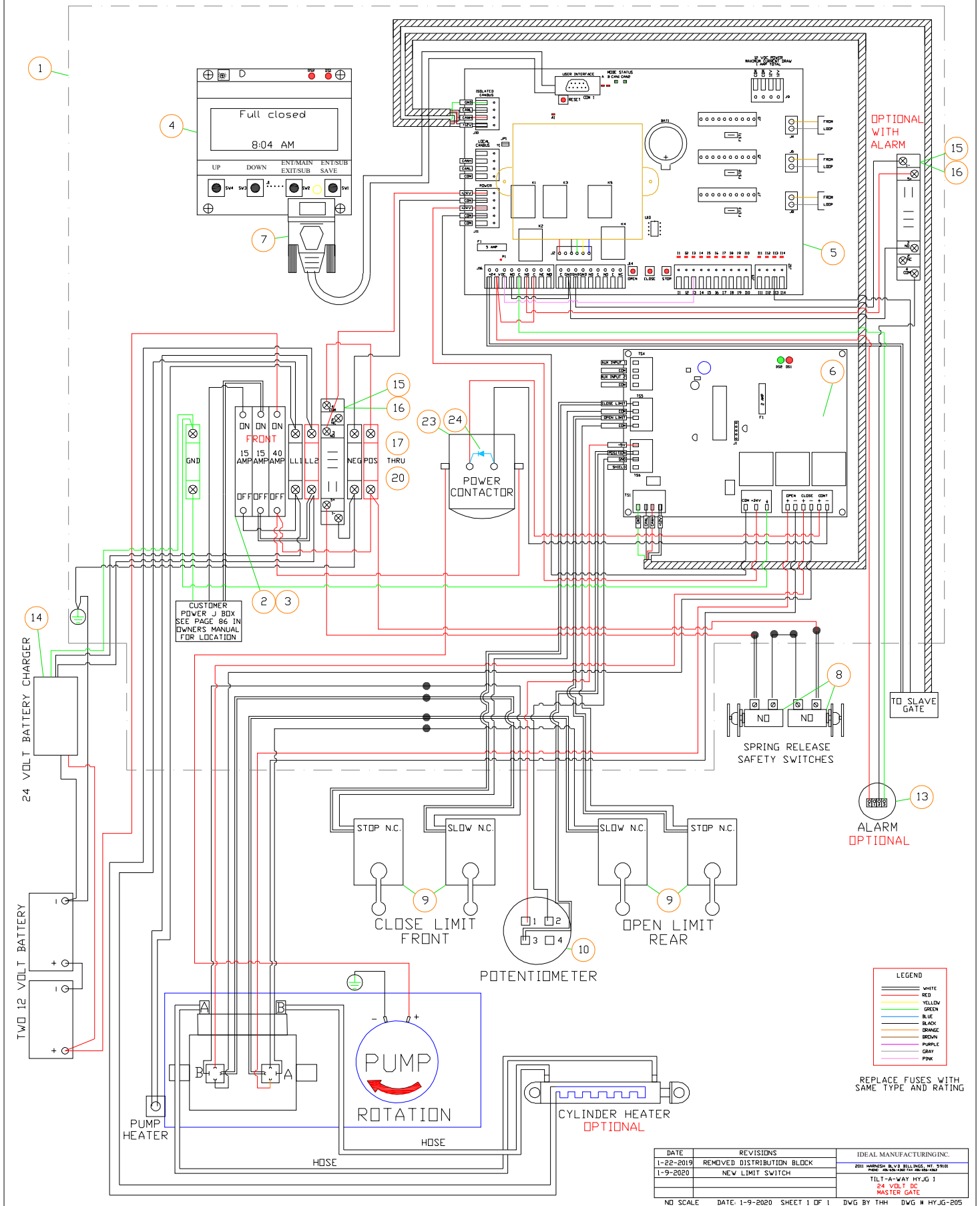

# TILT-A-WAY HYJG 1 SLAVE GATE 24 VOLT DC

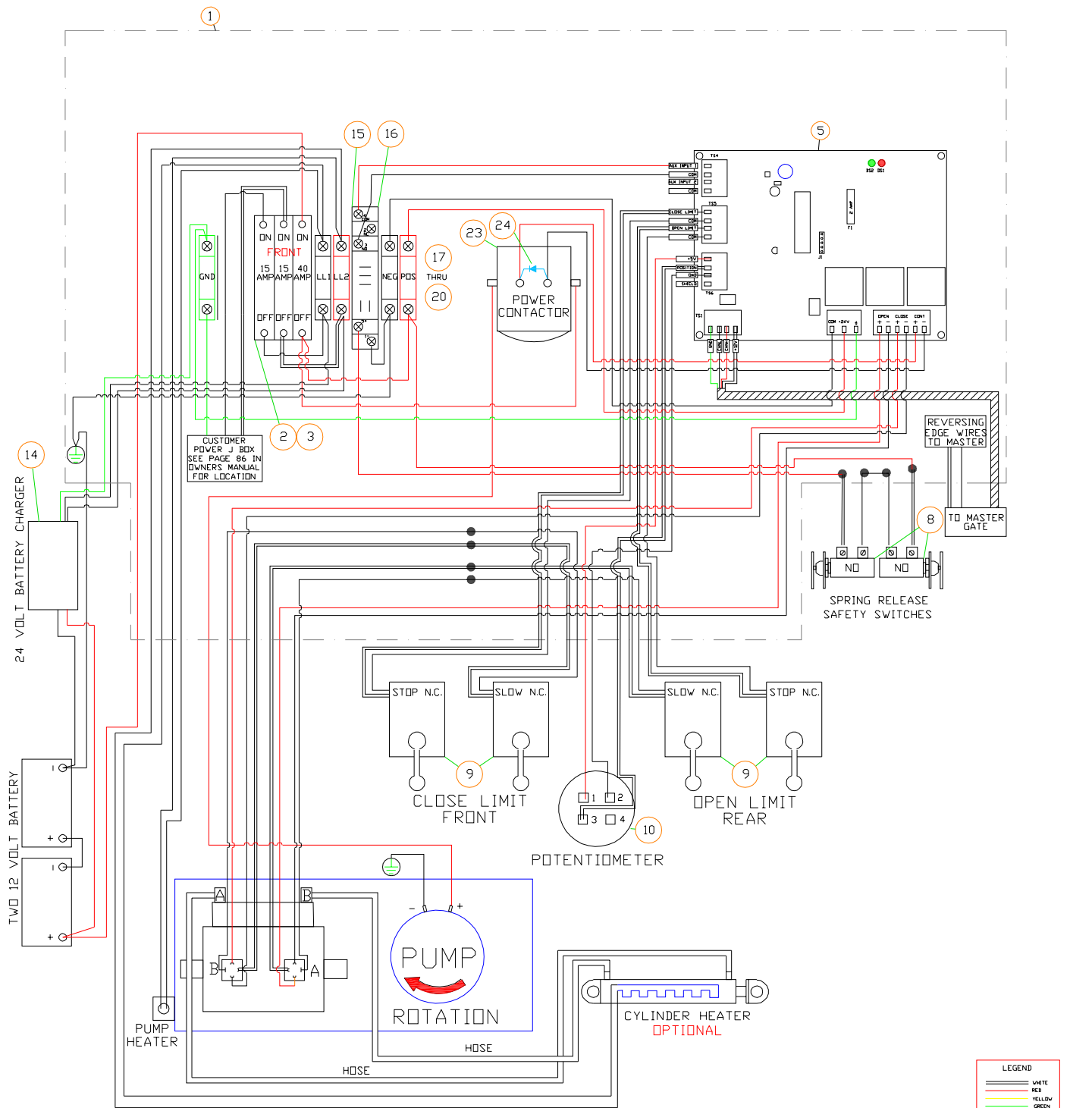

LEGEND	
—	WHITE
—	RED
—	YELLOW
—	GREEN
—	BLUE
—	BLACK
—	ORANGE
—	BROWN
—	PURPLE
—	GRAY
—	PINK

REPLACE FUSES WITH SAME TYPE AND RATING

DATE	REVISIONS	IDEAL MANUFACTURING INC.
1-22-2019	REMOVE DISTRIBUTION BLCK	2011 HANSON BLVD BILLINGS, MT 59101
1-9-2020	NEW LIMIT SWITCH	PHONE 406.253.7411 FAX 406.253.7567
		TILT-A-WAY HYJG 1
		24 VOLT DC
		SLAVE GATE

**TILT-A-WAY  
HYJG 1  
BASIC ELECTRICAL HARDWARE 240-VAC SINGLE PHASE  
DRAWING HYJG-207 ON PAGE 13 SINGLE GATE  
DRAWING HYJG-208 ON PAGE 14 MASTER GATE**

REF	PART NO.	DESCRIPTION	QTY
1	PEO961	ENCLOSURE	1
2	PEO602	CIRCUIT BREAKER	1
3	100117B	POWER SUPPLY (24-VDC)	1
4	PEO202I	INTERFACE BOARD	1
5	PEO202L	LOGIC BOARD	1
6	PEO202H	MOTOR BOARD	1
7	PEO202C	CONNECTING CORD	1
8	PEO611	SAFETY SWITCH	2
9	PEO963A	LIMIT SWITCH (nc)	4
10	100234-1	POTENTIOMETER	1
11	PEO223	½" ROMEX	3
12	PEO275	¾" ROMEX	3
13	100127	ALARM	1
14	PEO604	OVERLOAD RELAY	1
15	PEO605A	RELAY SOCKET 5 PIN	1
16	PEO679	RELAY 5 PIN SAFETY	1
17	PEO620	END BARRIER (not shown)	1
18	PEO621	GREEN TERMINAL BLOCK	1
19	PEO622	BLACK TERMINAL BLOCK	2
20	PEO623	RED TERMINAL BLOCK	2
21	PEO665	RADIO RECEIVER (optional not shown)	1
22	PEO663	RADIO TRANSMITTER (optional not shown)	as req.
23	100128	CONTACTOR	1

**DRAWING HYJG-209 ON PAGE 15 SLAVE GATE**

REF	PART NO.	DESCRIPTION	QTY
1	PEO292	ENCLOSURE	1
2	PEO602	CIRCUIT BREAKER	1
3	100117B	POWER SUPPLY (24-VDC)	1
6	PEO202H	MOTOR BOARD	1
8	PEO611	SAFETY SWITCH	2
9	PEO963A	LIMIT SWITCH (nc)	4
10	100234-1	POTENTIOMETER	1
11	PEO223	½" ROMEX	3
12	PEO275	¾" ROMEX	2
14	PEO604	OVERLOAD RELAY	1
15	PEO605A	RELAY SOCKET 5 PIN	1
16	PEO679	RELAY 5 PIN SAFETY	1
17	PEO620	END BARRIER (not shown)	1
18	PEO621	GREEN TERMINAL BLOCK	1
19	PEO622	BLACK TERMINAL BLOCK	2
20	PEO623	RED TERMINAL BLOCK	2
23	100128	CONTACTOR	1

# TILT-A-WAY HYJG 1 SINGLE GATE 240 VOLT SINGLE PHASE

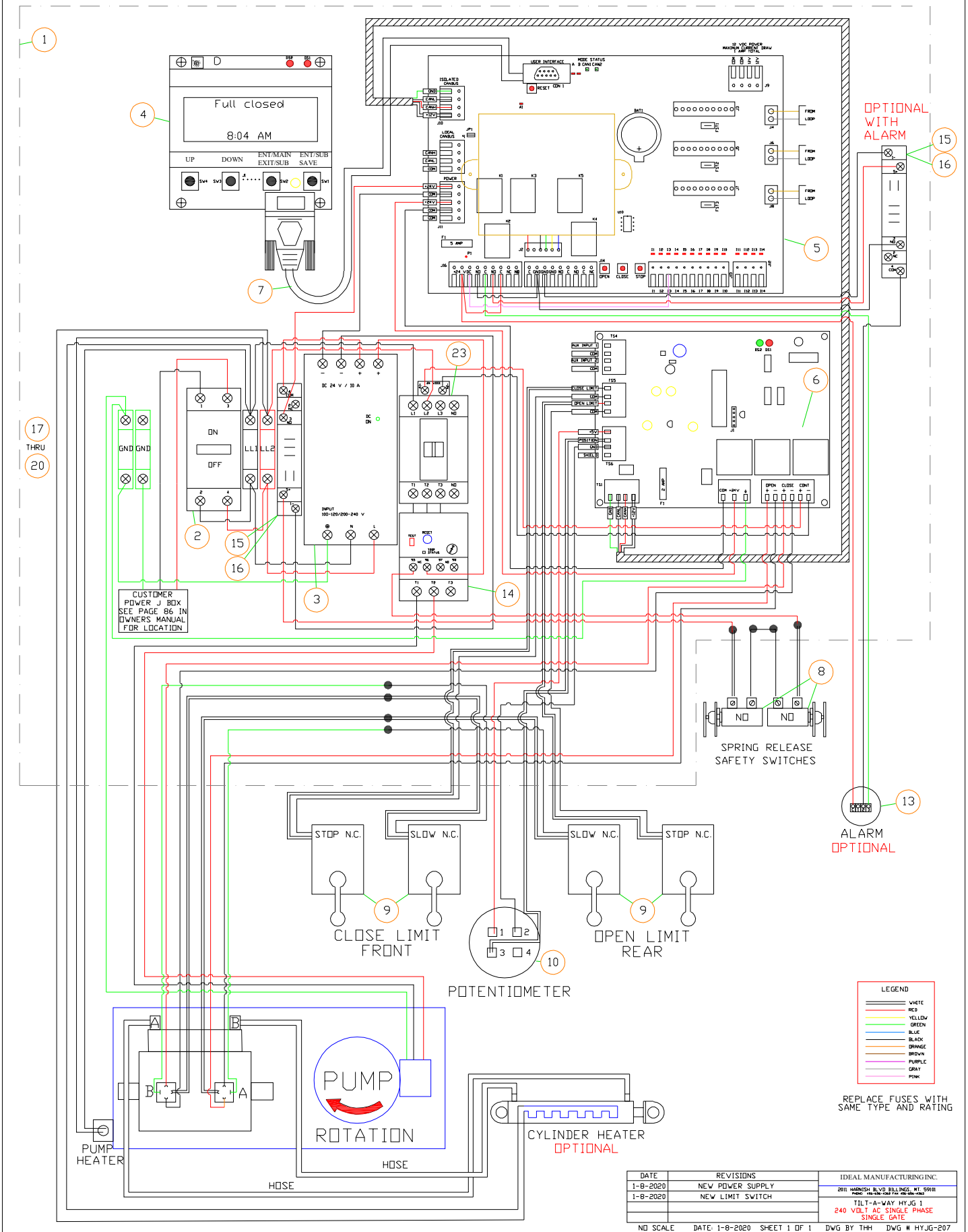

DATE	REVISIONS	IDEAL MANUFACTURING INC.
1-8-2020	NEW POWER SUPPLY	2011 HARDEN BLVD, BELLMEAD, NJ 07018 PHONE: 908-261-0000 FAX: 908-261-0001
1-8-2020	NEW LIMIT SWITCH	
		TILT-A-WAY HYJG 1 240 VOLT AC SINGLE PHASE SINGLE GATE
NO SCALE	DATE: 1-8-2020 SHEET 1 OF 1	DWG BY THH DWG # HYJG-207



# TILT-A-WAY HYJG 1 MASTER GATE 240 VOLT SINGLE PHASE

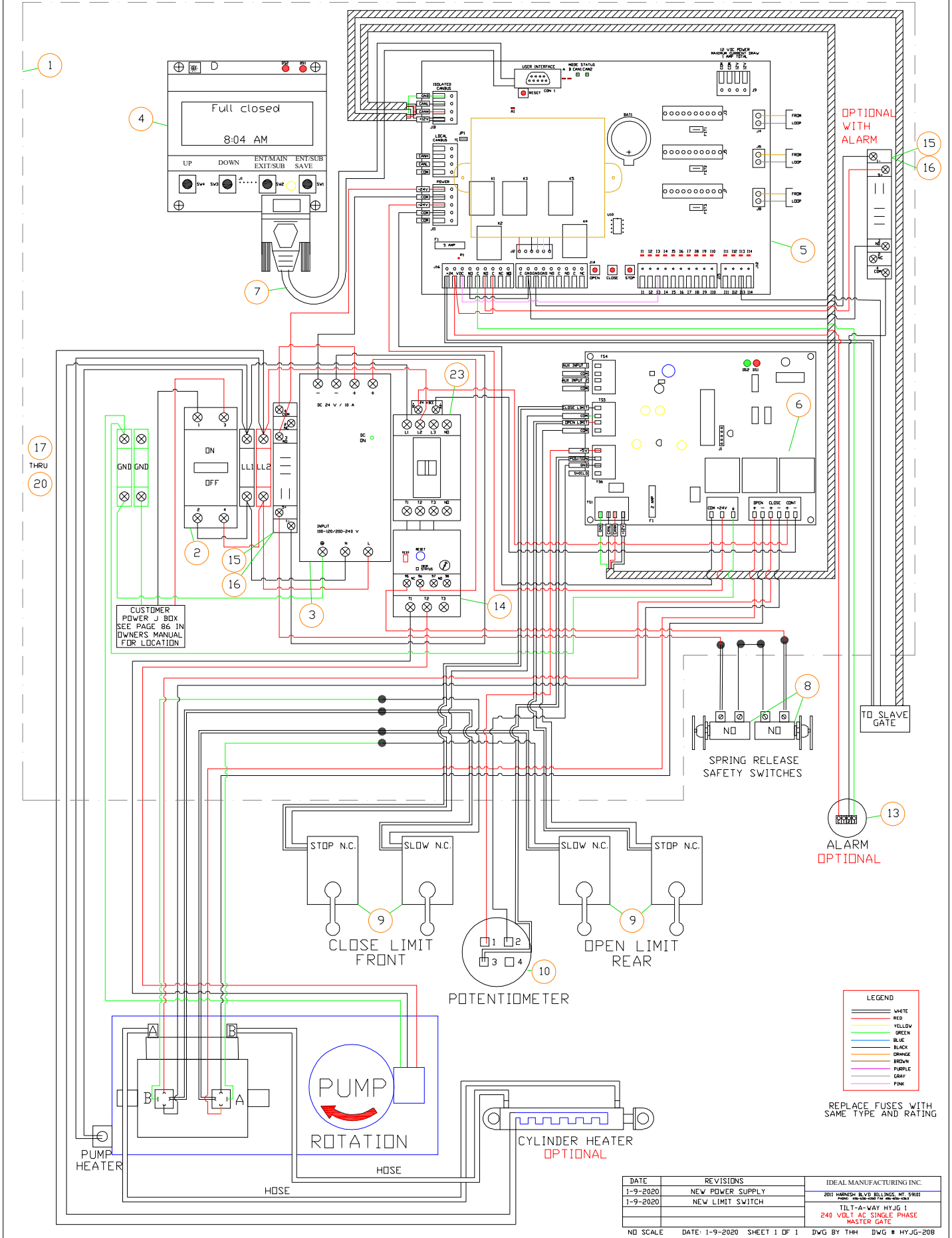

# TILT-A-WAY HYJG 1 SLAVE GATE 240 VOLT SINGLE PHASE

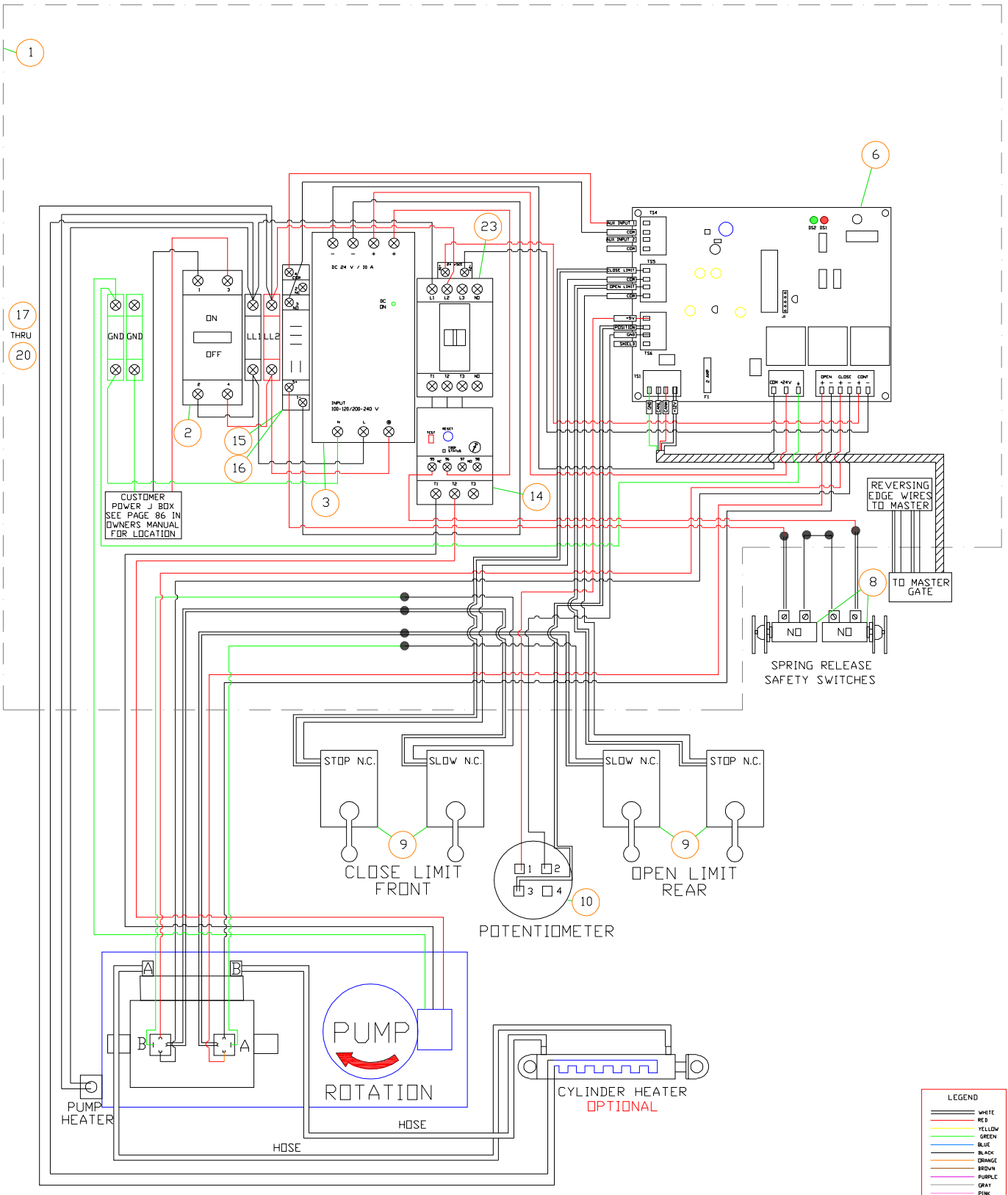

LEGEND	
—	WHITE
—	RED
—	YELLOW
—	GREEN
—	BLUE
—	BLACK
—	ORANGE
—	BROWN
—	PURPLE
—	GRAY
—	PINK

REPLACE FUSES WITH SAME TYPE AND RATING

DATE	REVISIONS	IDEAL MANUFACTURING INC.
1-9-2020	NEW POWER SUPPLY	2011 MANHATTAN BLVD. BILLINGS, MT. 59101
1-9-2020	NEW LIMIT SWITCH	PHONE: 406.248.7272 FAX: 406.248.7274
		TILT-A-WAY HYJG 1
		240 VOLT AC SINGLE PHASE
		SLAVE GATE

NO SCALE DATE: 1-9-2020 SHEET 1 OF 1 DWG BY THH DWG # HYJG-209

**TILT-A-WAY HYJG 1**  
**BASIC ELECTRICAL HARDWARE 240-VAC THREE PHASE**  
**DRAWING HYJG-210 ON PAGE 17 SINGLE GATE**  
**DRAWING HYJG-211 ON PAGE 18 MASTER GATE**

REF	PART NO.	DESCRIPTION	QTY
1	PEO961	ENCLOSURE	1
2	PEO640	CIRCUIT BREAKER	1
3	100117B	POWER SUPPLY (24-VDC)	1
4	PEO202I	INTERFACE BOARD	1
5	PEO202L	LOGIC BOARD	1
6	PEO202H	MOTOR BOARD	1
7	PEO202C	CONNECTING CORD	1
8	PEO611	SAFETY SWITCH	2
9	PEO963A	LIMIT SWITCH (nc)	4
10	100234-1	POTENTIOMETER	1
11	PEO223	½" ROMEX	3
12	PEO275	¾" ROMEX	3
13	100127	ALARM	1
14	PEO268-1	OVERLOAD RELAY	1
15	PEO605A	RELAY SOCKET 5 PIN	1
16	PEO679	RELAY 5 PIN SAFETY	1
17	PEO620	END BARRIER (not shown)	1
18	PEO621	GREEN TERMINAL BLOCK	1
19	PEO644	BROWN TERMINAL BLOCK	2
20	PEO645	YELLOW TERMINAL BLOCK	2
21	PEO646	ORANGE TERMINAL BLOCK	2
22	100128	CONTACTOR	1

**DRAWING HYJG-212 ON PAGE 19 SLAVE GATE**

REF	PART NO.	DESCRIPTION	QTY
1	PEO292	ENCLOSURE	1
2	PEO640	CIRCUIT BREAKER	1
3	100117B	POWER SUPPLY (24-VDC)	1
6	PEO202H	MOTOR BOARD	1
8	PEO611	SAFETY SWITCH	2
9	PEO963A	LIMIT SWITCH (nc)	4
10	100234-1	POTENTIOMETER	1
11	PEO223	½" ROMEX	3
12	PEO275	¾" ROMEX	2
14	PEO268-1	OVERLOAD RELAY	1
15	PEO605A	RELAY SOCKET 5 PIN	1
16	PEO679	RELAY 5 PIN SAFETY	1
17	PEO620	END BARRIER (not shown)	1
18	PEO621	GREEN TERMINAL BLOCK	1
19	PEO644	BROWN TERMINAL BLOCK	2
20	PEO645	YELLOW TERMINAL BLOCK	2
21	PEO646	ORANGE TERMINAL BLOCK	2
22	100128	CONTACTOR	1

# TILT-A-WAY HYJG 1 SINGLE GATE 240 VOLT THREE PHASE

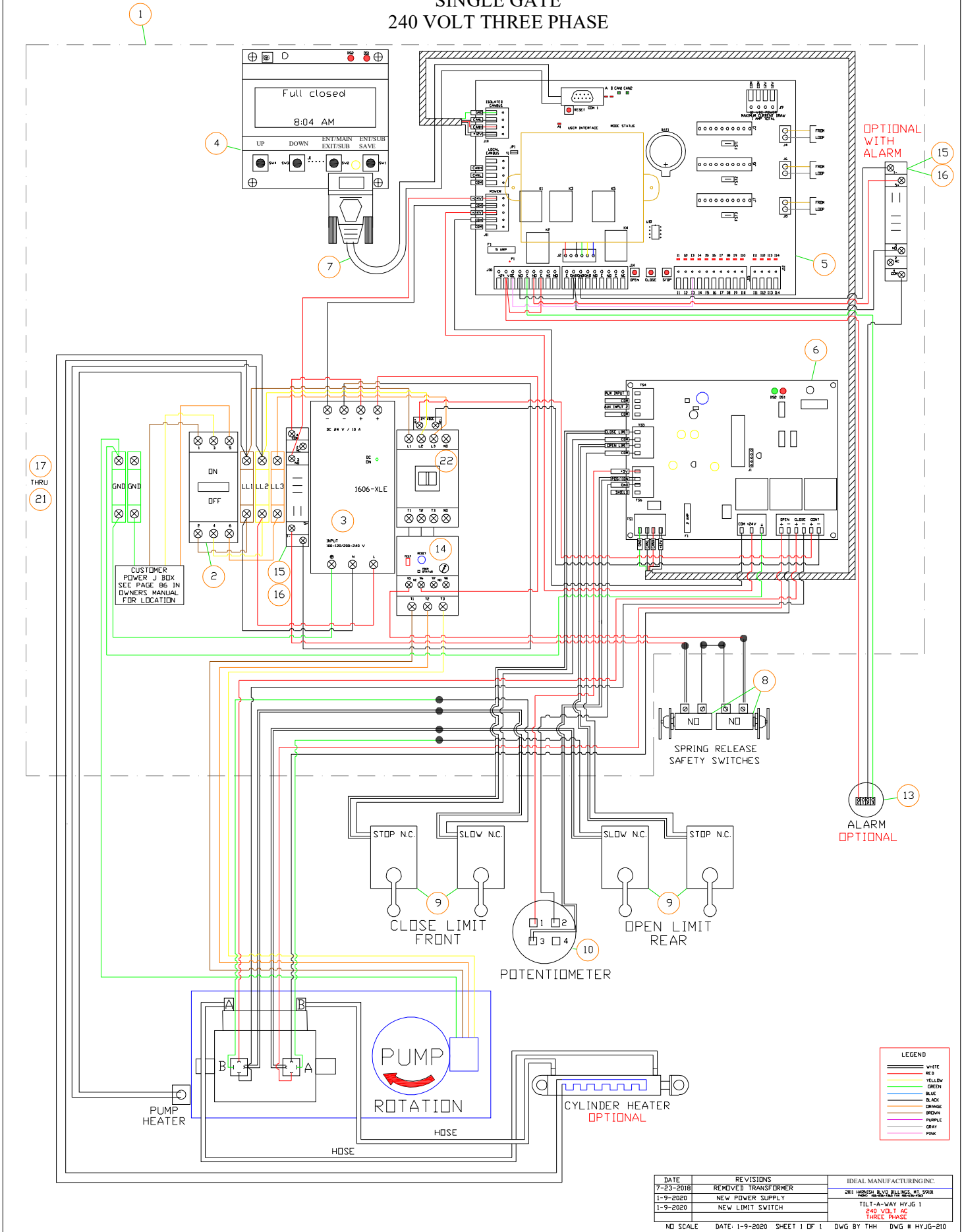

# TILT-A-WAY HYJG 1 MASTER GATE 240 VOLT THREE PHASE

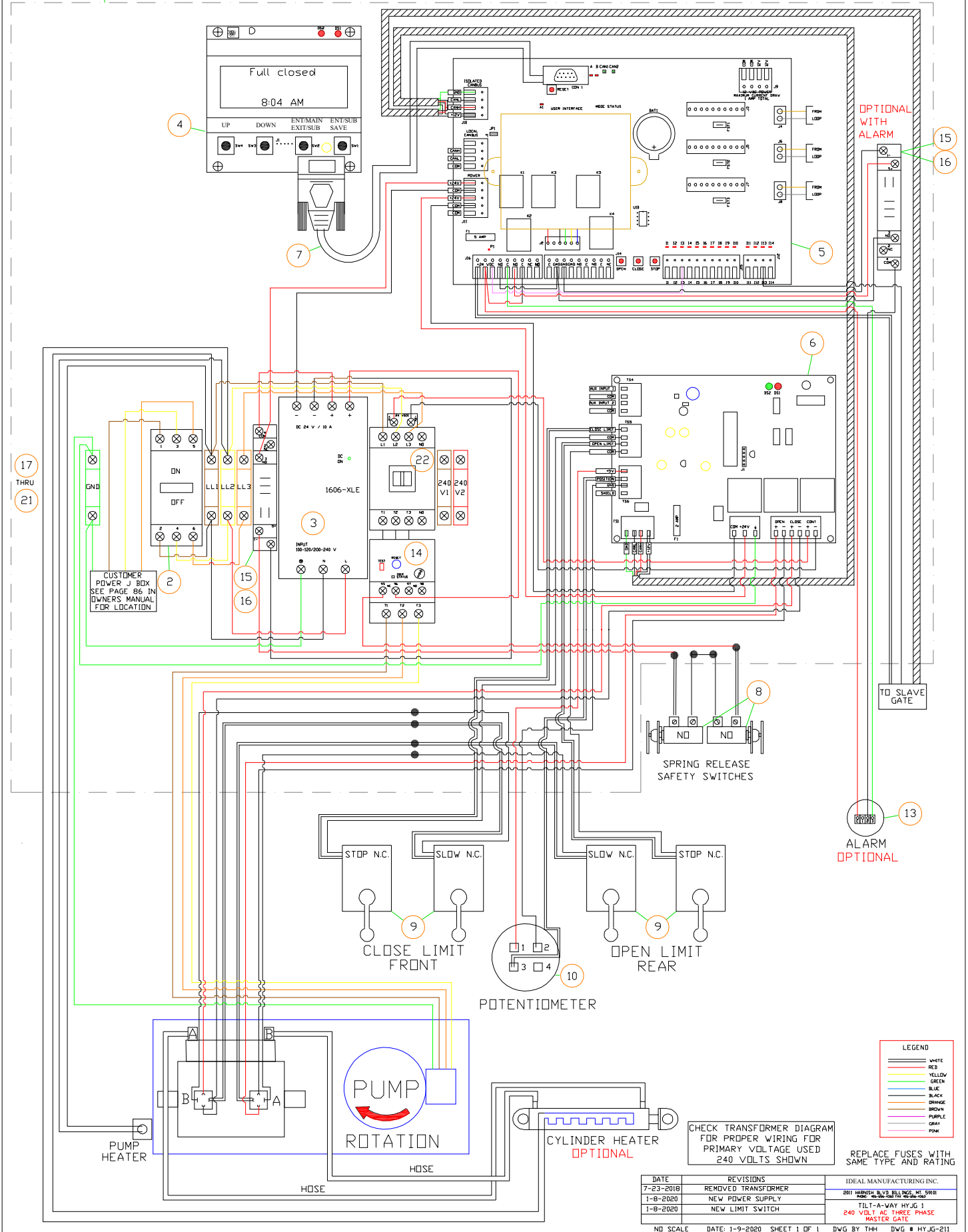

# TILT-A-WAY HYJG 1 SLAVE GATE 240 VOLT THREE PHASE

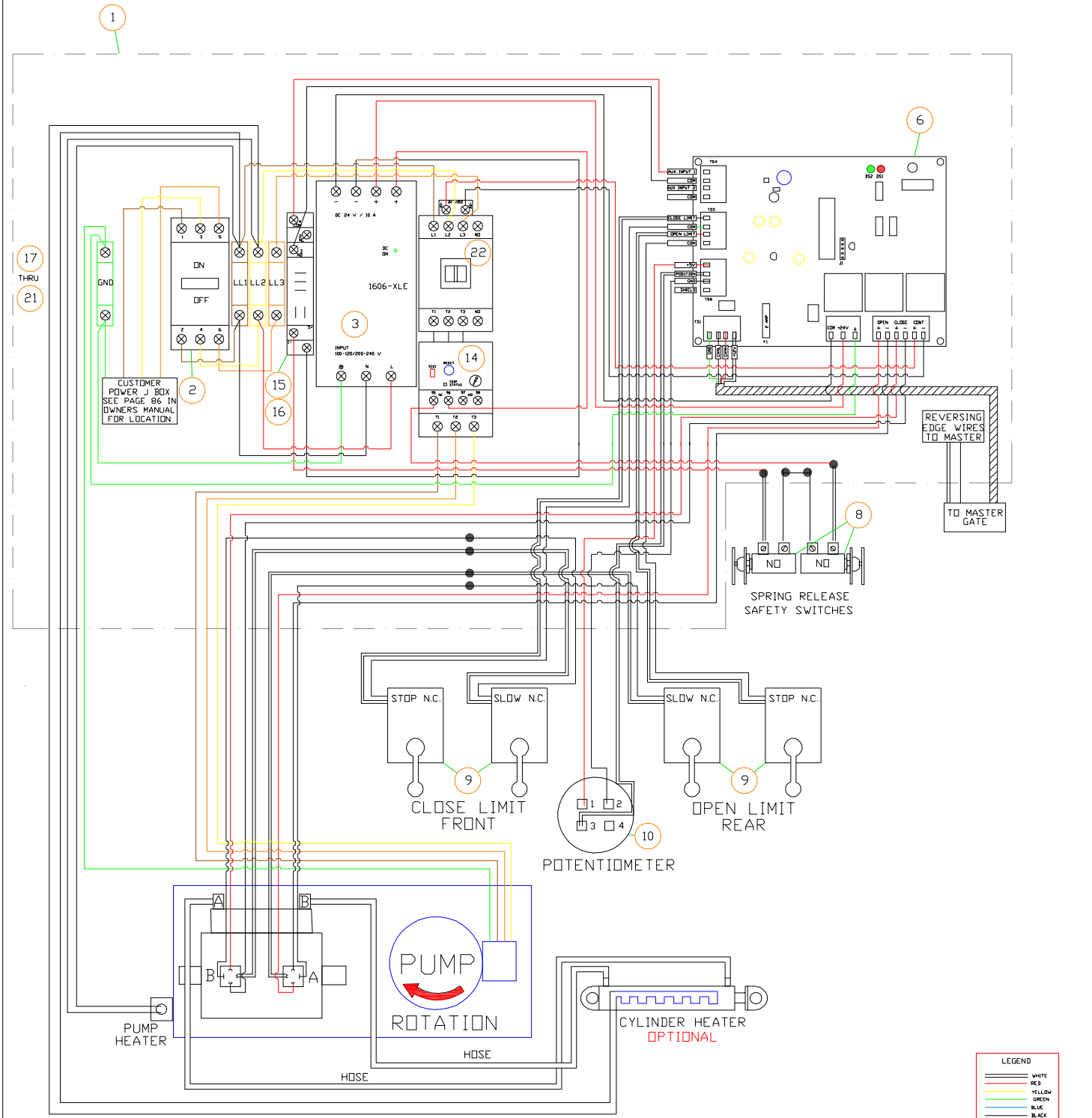

LEGEND	
WHITE	RED
YELLOW	GREEN
BLUE	BLACK
ORANGE	BROWN
PURPLE	GRAY
PINK	

REPLACE FUSES WITH SAME TYPE AND RATING

DATE	REVISIONS	IDEAL MANUFACTURING INC.
7-23-2018	REMOVED TRANSFORMER	2011 HARRIS BLVD. BELLINGHAM, WA 98101
1-8-2020	NEW POWER SUPPLY	PHONE: 360-885-5851 FAX: 360-885-5852
1-8-2020	NEW LIMIT SWITCH	TILT-A-WAY HYJG 1 240 VOLT AC THREE PHASE SLAVE GATE

NO SCALE DATE: 1-9-2020 SHEET 1 OF 1 DWG BY THH DWG # HYJG-212

**TILT-A-WAY HYJG 1**  
**BASIC ELECTRICAL HARDWARE 480-VAC THREE PHASE**  
**DRAWING HYJG-213 ON PAGE 21 SINGLE GATE**  
**DRAWING HYJG-214 ON PAGE 22 MASTER GATE**

REF	PART NO.	DESCRIPTION	QTY
1	PEO961	ENCLOSURE	1
2	PEO640	CIRCUIT BREAKER	1
3	100117B	POWER SUPPLY (24-VDC)	1
4	PEO202I	INTERFACE BOARD	1
5	PEO202L	LOGIC BOARD	1
6	PEO202H	MOTOR BOARD	1
7	PEO202C	CONNECTING CORD	1
8	PEO611	SAFETY SWITCH	2
9	PEO963A	LIMIT SWITCH (nc)	4
10	100234-1	POTENTIOMETER	1
11	PEO223	½" ROMEX	3
12	PEO275	¾" ROMEX	3
13	100127	ALARM	1
14	PEO268-1	OVERLOAD RELAY	1
15	PEO605A	RELAY SOCKET 5 PIN	1
16	PEO679	RELAY 5 PIN SAFETY	1
17	PEO620	END BARRIER (not shown)	1
18	PEO621	GREEN TERMINAL BLOCK	1
19	PEO644	BROWN TERMINAL BLOCK	2
20	PEO645	YELLOW TERMINAL BLOCK	2
21	PEO646	ORANGE TERMINAL BLOCK	2
22	PEO622	BLACK TERMINAL BLOCK	1
23	PEO623	RED TERMINAL BLOCK	1
24	PEO647	FUSE TERMINAL BLOCK	2
25	PEO648	FUSE 4 AMP 600 VOLT	2
26	100128	CONTACTOR	1
27	PEO280	TRANSFORMER 1PH .500 KVA	1

**DRAWING HYJG-215 ON PAGE 23 SLAVE GATE**

REF	PART NO.	DESCRIPTION	QTY
1	PEO292	ENCLOSURE	1
2	PEO640	CIRCUIT BREAKER	1
3	100117B	POWER SUPPLY (24-VDC)	1
6	PEO202H	MOTOR BOARD	1
8	PEO611	SAFETY SWITCH	2
9	PEO963A	LIMIT SWITCH (nc)	4
10	100234-1	POTENTIOMETER	1
11	PEO223	½" ROMEX	3
12	PEO275	¾" ROMEX	2
14	PEO268-1	OVERLOAD RELAY	1
15	PEO605A	RELAY SOCKET 5 PIN	1
16	PEO679	RELAY 5 PIN SAFETY	1
17	PEO620	END BARRIER (not shown)	1
18	PEO621	GREEN TERMINAL BLOCK	1
19	PEO644	BROWN TERMINAL BLOCK	2
20	PEO645	YELLOW TERMINAL BLOCK	2
21	PEO646	ORANGE TERMINAL BLOCK	2
22	PEO622	BLACK TERMINAL BLOCK	1
23	PEO623	RED TERMINAL BLOCK	1
24	PEO647	FUSE TERMINAL BLOCK	2
25	PEO648	FUSE 4 AMP 600 VOLT	2
26	100128	CONTACTOR	1
27	PEO280	TRANSFORMER 1PH .500KVA	1

# TILT-A-WAY HYJG 1 SINGLE GATE 480 VOLT THREE PHASE

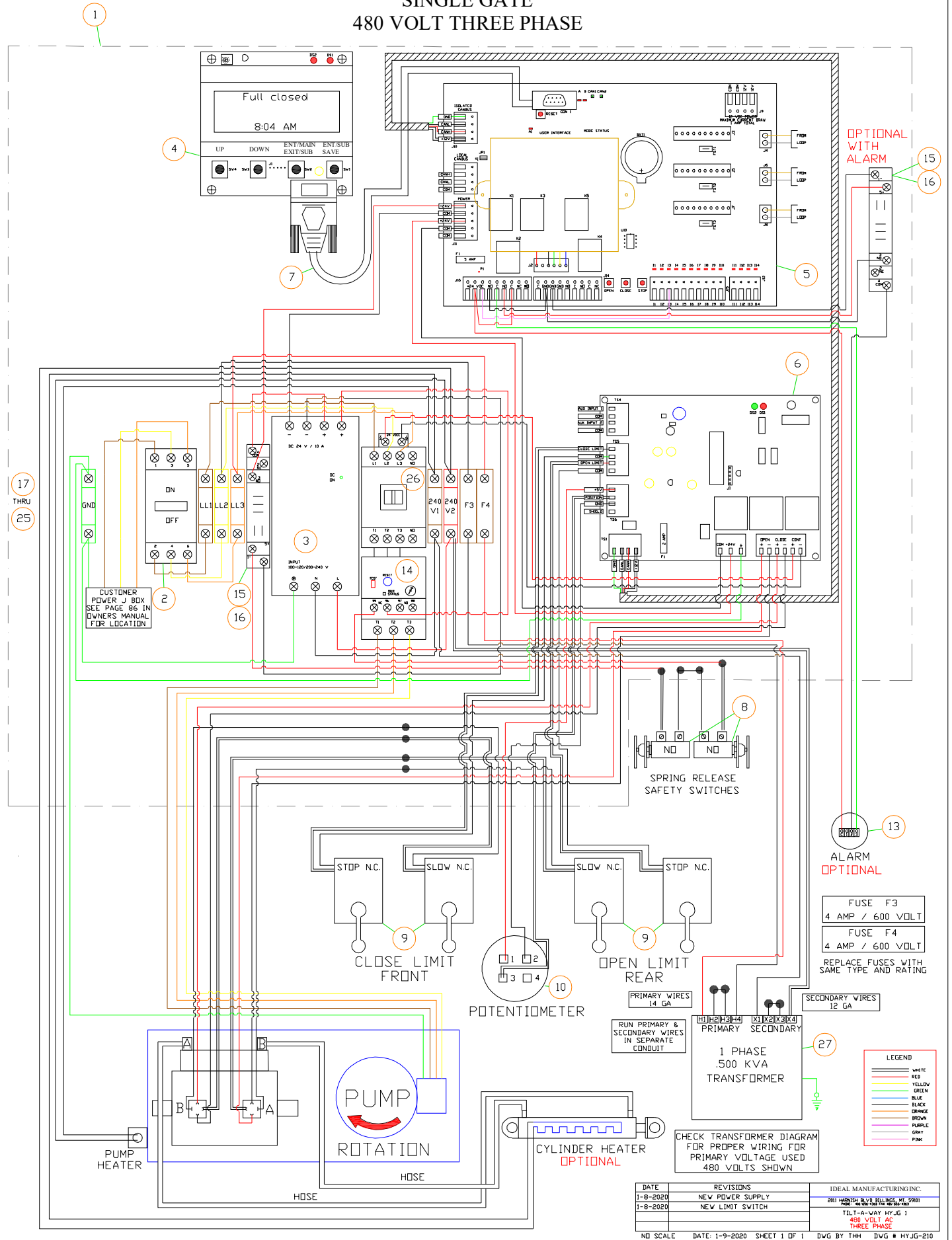



# TILT-A-WAY HYJG 1 MASTER GATE 480 VOLT THREE PHASE

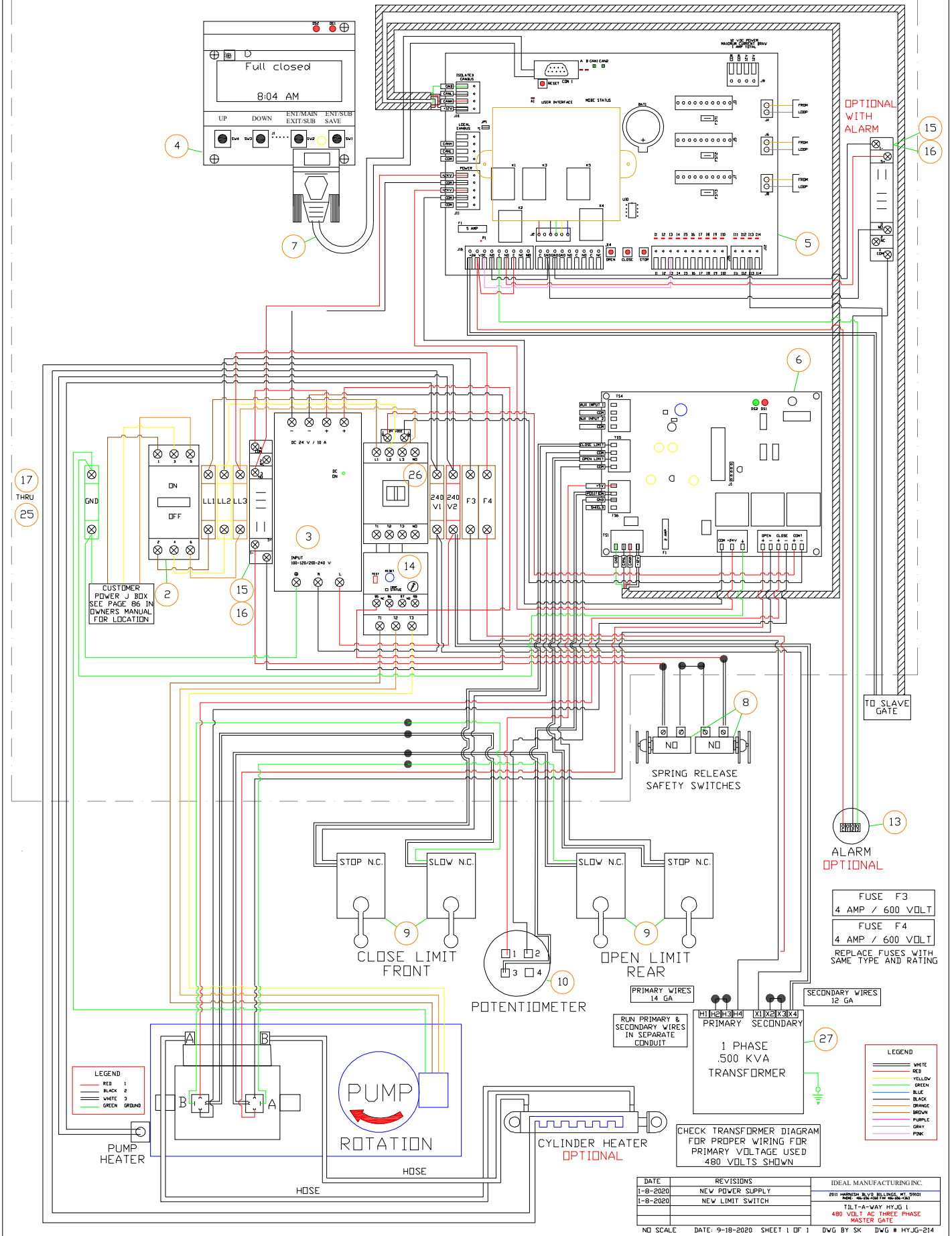

# TILT-A-WAY HYJG 1 SLAVE GATE 480 VOLT THREE PHASE

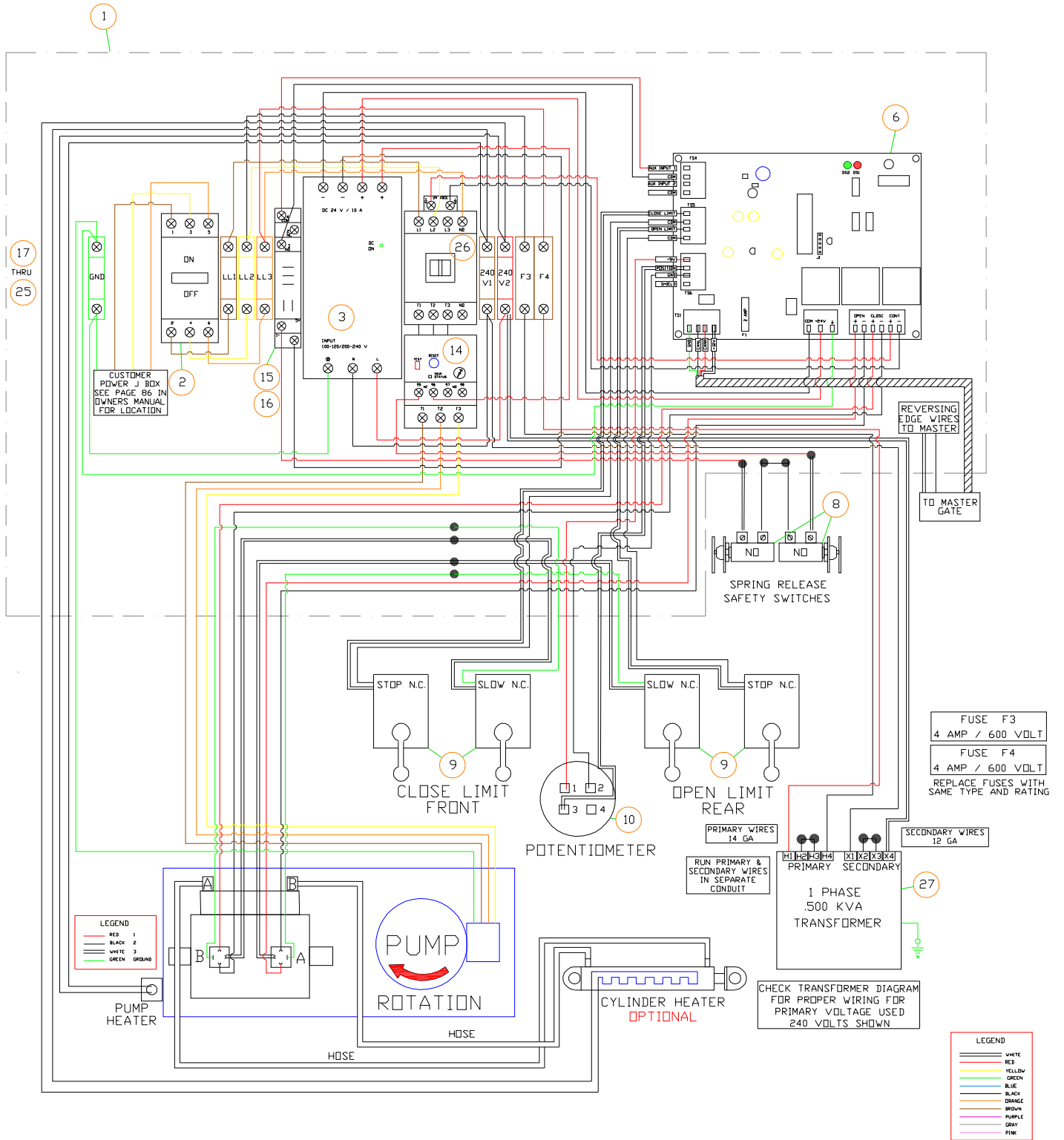

DATE	REVISIONS	IDEAL MANUFACTURING INC.
8-10-2020	NEW POWER SUPPLY	201 HANSHI BLVD BELLINGHAM, WA 98221 PHONE: 360-338-7777 FAX: 360-338-7778
8-10-2020	NEW LIMIT SWITCH	TILT-A-WAY HYJG 1 480 VOLT AC THREE PHASE SLAVE GATE
NO SCALE	DATE: 9-18-2020 SHEET 1 OF 1	DWG BY SK DWG # HYJG-215

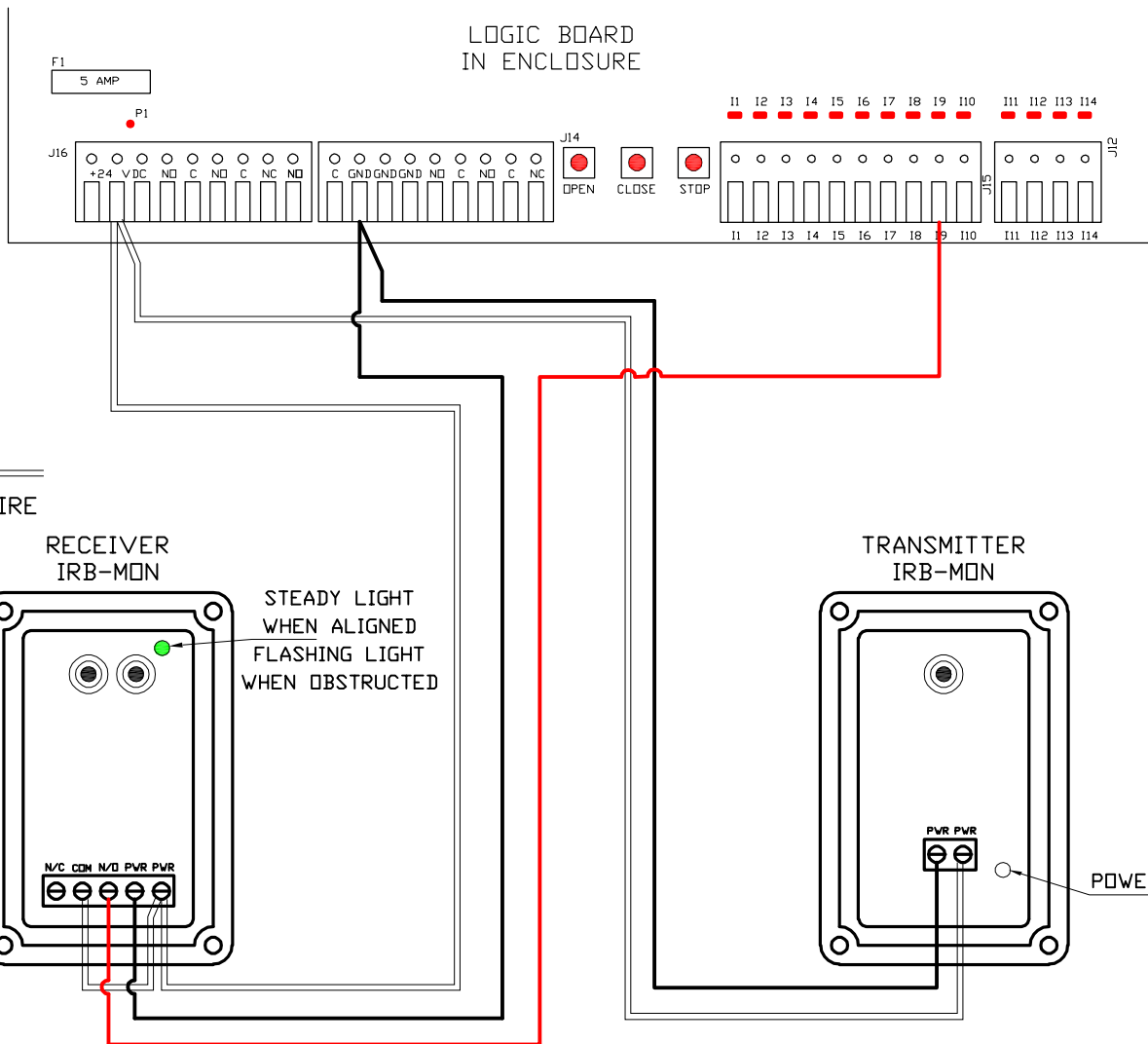

THE RECEIVER N/O CONTACT IS CONNECTED TO TERMINAL 19 ON THE LOGIC BOARD.  
FOR THE PHOTO EYE TO ACT AS A SAFETY AUXILIARY #1 INPUT FUNCTION ASSIGNMENT WILL BE SET TO  
"REVERSE OPEN LOOP"  
PRESS AND HOLD BUTTON SW2 ON THE INTERFACE BOARD UNTIL DISPLAY CHANGES THEN RELEASE THE BUTTON  
PRESS BUTTON SW4 AND RELEASE UNTIL THE DISPLAY SHOWS  
"TIMING AND OPTIONS"  
PRESS AND RELEASE BUTTON SW1 TO ENTER THE MENU THE DISPLAY WILL CHANGE TO  
"TIMINGS AND OPTIONS"  
"BASIC SETTINGS"  
CONTINUE TO PRESS AND RELEASE BUTTON SW4 UNTIL THE DISPLAY SHOWS  
"TIMINGS AND OPTIONS"  
"AUXILIARY I / O"  
PRESS AND RELEASE BUTTON SW1 TO ENTER THE SUBMENU THE DISPLAY WILL SHOW  
"AUXILIARY # 1 INPUT FUNCTION ASSIGNMENT"  
PRESS AND RELEASE BUTTON SW1 TO ENTER  
PRESS AND RELEASE BUTTON SW4 UNTIL THE DISPLAY SHOWS  
"REVERSE OPEN LOOP"  
PRESS AND RELEASE BUTTON SW1 TO SAVE  
PRESS AND RELEASE BUTTON SW2 UNTIL YOU EXIT ALL MENUS  
THE GATE WILL STOP AND REVERSE WHEN CLOSING TO FULL OPEN AND SET THE AUTO CLOSE TIMER

### TILT-A-WAY HYJG 1 REFLECTIVE TYPE PHOTO EYE

REF NO.	PART NO.	DESCRIPTION	REQ NO
1	PEO404 (set)	Photo Eye 24-VDC	1
2	PEO405	Hood ( not shown)	2

**TILT-A-WAY  
HYJG 1  
12 VOLT DC  
SAFETY WARNING LIGHT**

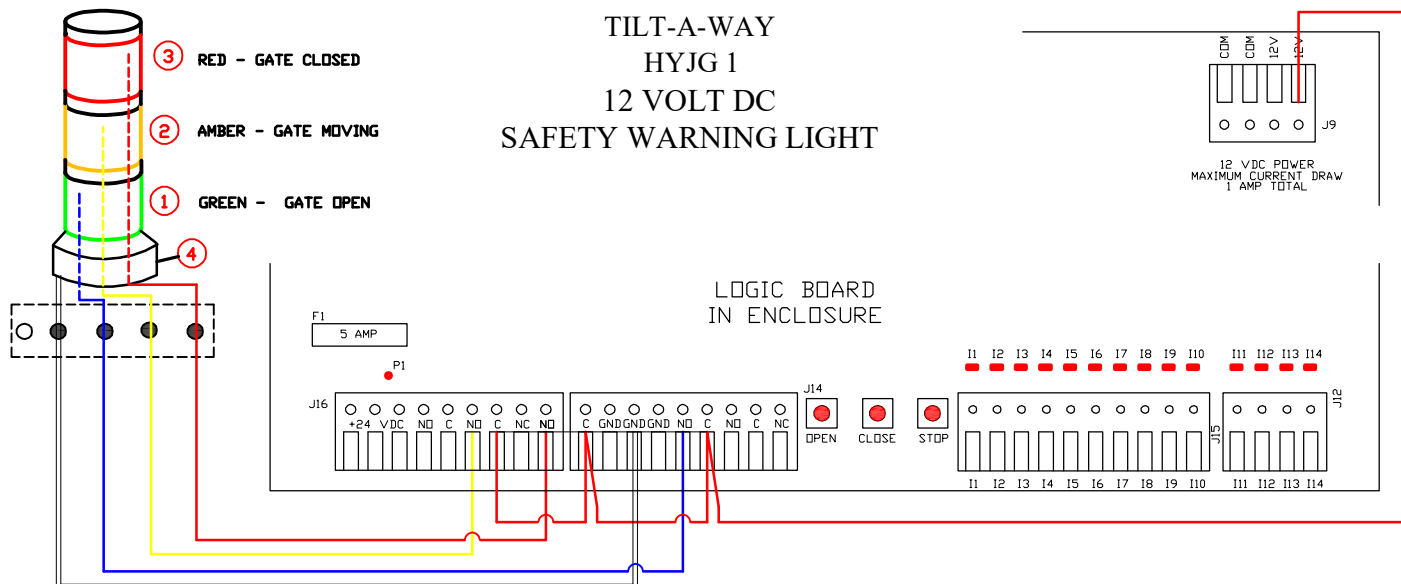

WHITE WIRE

TILT-A-WAY HYJG  
24 VOLT DC SAFETY WARNING LIGHTS ARE CONNECTED TO THE NORMALLY OPEN CONTACTS  
RED LIGHT "GATE CLOSED" IS CONNECTED TO AUXILIARY OUTPUT # 1  
AMBER LIGHT "GATE MOVING" IS CONNECTED TO PREWARN OUTPUT  
GREEN LIGHT "GATE OPEN" IS CONNECTED TO AUXILIARY OUTPUT # 2  
THE OUTPUT FUNCTIONS FOR AUXILIARY OUTPUT # 1 AND # 2 NEED TO BE SET AS FOLLOVED  
PRESS AND HOLD BUTTON SW2 ON THE INTERFACE BOARD UNTIL THE DISPLAY CHANGES  
RELEASE THE SW2 BUTTON AND THE DISPLAY WILL SHOW

**MAIN MENU**

**UP / DOWN - VIEW MENUS**

**SELECT - VIEW / EDIT**

**RESET - EXIT**

PRESS AND RELEASE BUTTON SW4 UNTIL THE DISPLAY SHOWS

**TIMING AND OPTIONS**

PRESS AND RELEASE BUTTON SW1 TO ENTER THE MENU

PRESS AND RELEASE BUTTON SW4 UNTIL THE DISPLAY SHOWS

**AUXILIARY I / O**

PRESS AND RELEASE BUTTON SW1 TO ENTER THE SUBMENU

PRESS AND RELEASE BUTTON SW4 UNTIL THE DISPLAY SHOWS

**AUXILIARY OUTPUT # 1 FUNCTION**

PRESS AND RELEASE BUTTON SW1 TO ENTER THE SUBMENU

PRESS AND RELEASE BUTTON SW4 UNTIL THE DISPLAY SHOWS

**HOLD AUX RELAY ON CLOSE LIMIT SWITCH**

PRESS AND RELEASE BUTTON SW1 TO SAVE SELECTION

PRESS AND RELEASE BUTTON SW2 TO EXIT SUBMENU

PRESS AND RELEASE BUTTON SW4 UNTIL DISPLAY SHOWS

**AUXILIARY OUTPUT # 2 FUNCTION**

PRESS AND RELEASE BUTTON SW1 TO ENTER THE SUBMENU

PRESS AND RELEASE BUTTON SW4 UNTIL THE DISPLAY SHOWS

**HOLD AUX RELAY ON OPEN LIMIT SWITCH**

PRESS AND RELEASE BUTTON SW1 TO SAVE SELECTION

PRESS AND RELEASE BUTTON SW2 UNTIL YOU HAVE EXITED ALL MENUS

REF. NO.	PART NO.	DESCRIPTION	REQ. NO.
1	PEO366	Light Module - Green - Steady 12 VDC	1
2	PEO368	Light Module - Amber - Flashing 12 VDC	1
3	PEO367	Light Module - Red - Steady 12 VDC	1
4	PEO360	Pole Mount Base	
	PEO369	Single Tone Sound Module (not shown) (Optional) 12 VDC	
	PEO370	Incandescent Lamp (not shown) (replacement) 12 VDC	

# TILT-A-WAY HYJG 1 ELECTROMAGNETIC LOCK

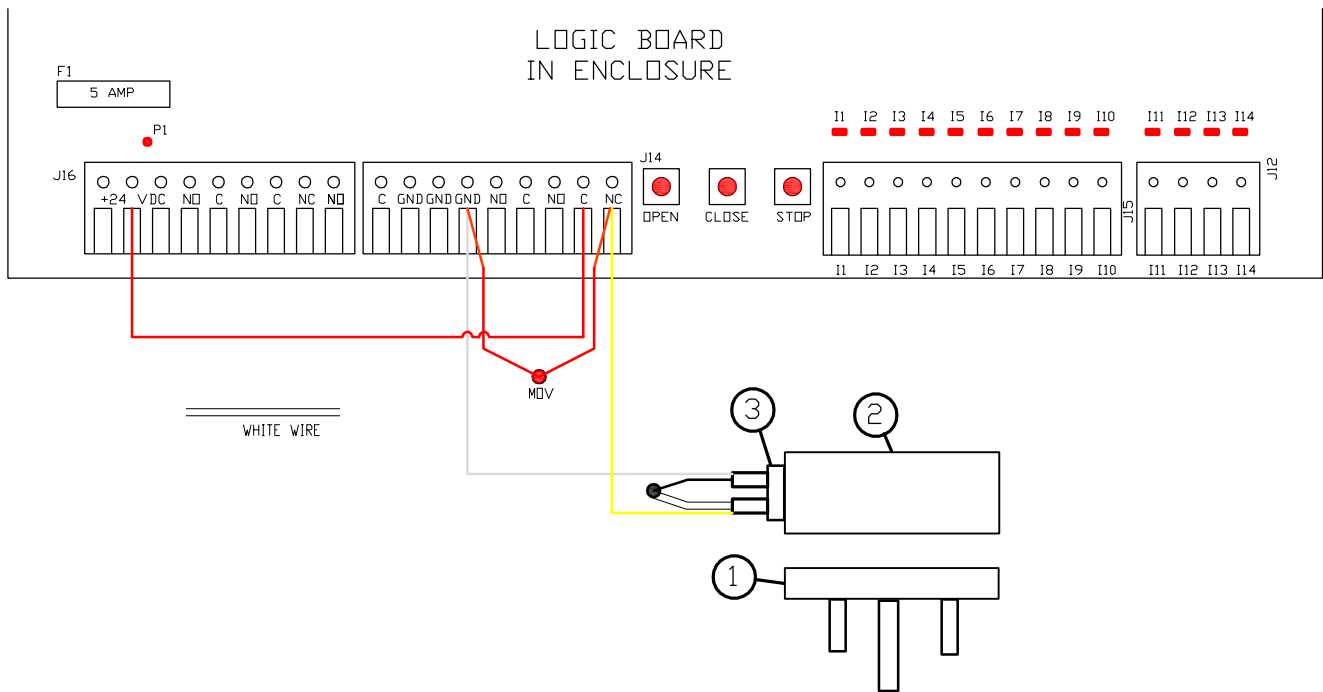

THE ELECTROMAGNETIC LOCK IS CONNECTED TO AUXILIARY OUTPUT RELAY # 3  
 THE AUXILIARY OUT PUT RELAY NEEDS TO BE SET TO UNLOCK PULSE  
 PRESS AND HOLD BUTTON SW2 ON THE INTERFACE BOARD UNTIL THE DISPLAY CHANGES  
 RELEASE THE SW2 BUTTON AND THE DISPLAY WILL SHOW

**MAIN MENU**

**UP / DOWN - VIEW MENUS**

**SELECT - VIEW / EDIT**

**RESET - EXIT**

PRESS AND RELEASE BUTTON SW4 UNTIL THE DISPLAY SHOWS

**TIMING AND OPTIONS**

PRESS AND RELEASE BUTTON SW1 TO ENTER THE MENU

PRESS AND RELEASE BUTTON SW4 UNTIL THE DISPLAY SHOWS

**AUXILIARY I / O**

PRESS AND RELEASE BUTTON SW1 TO ENTER THE SUBMENU

PRESS AND RELEASE BUTTON SW4 UNTIL THE DISPLAY SHOWS

**AUXILIARY OUTPUT # 3 FUNCTION**

PRESS AND RELEASE BUTTON SW1 TO ENTER THE SUBMENU

PRESS AND RELEASE BUTTON SW4 UNTIL THE DISPLAY SHOWS

**UNLOCK PULSE**

PRESS AND RELEASE BUTTON SW1 TO SAVE SELECTION

PRESS AND RELEASE SW2 SWITCH

PRESS AND RELEASE SW4 BUTTON UNTIL THE DISPLAY SHOWS

**AUXILIARY OUTPUT #3 PULSE DURATION**

PRESS AND RELEASE BUTTON SW1 TO ENTER THE SUBMENU

PRESS THE SW4 BUTTON TO CHANGE TO 5.00 SECONDS

PRESS AND RELEASE BUTTON SW2 UNTIL YOU HAVE EXITED ALL MENUS

REF NO.	PART NO.	DESCRIPTION	REQ NO
1	PEO277	Electromagnetic Armature (Located stationary at outer end of barrier or at outer end of an opposite barrier)	1
2	PEO277	Electromagnetic Lock ( Located at outer end of barrier 24 VDC)	1
3	PEO246	1/2" Strain Relief Fitting (one at barrier lower pipe)	1

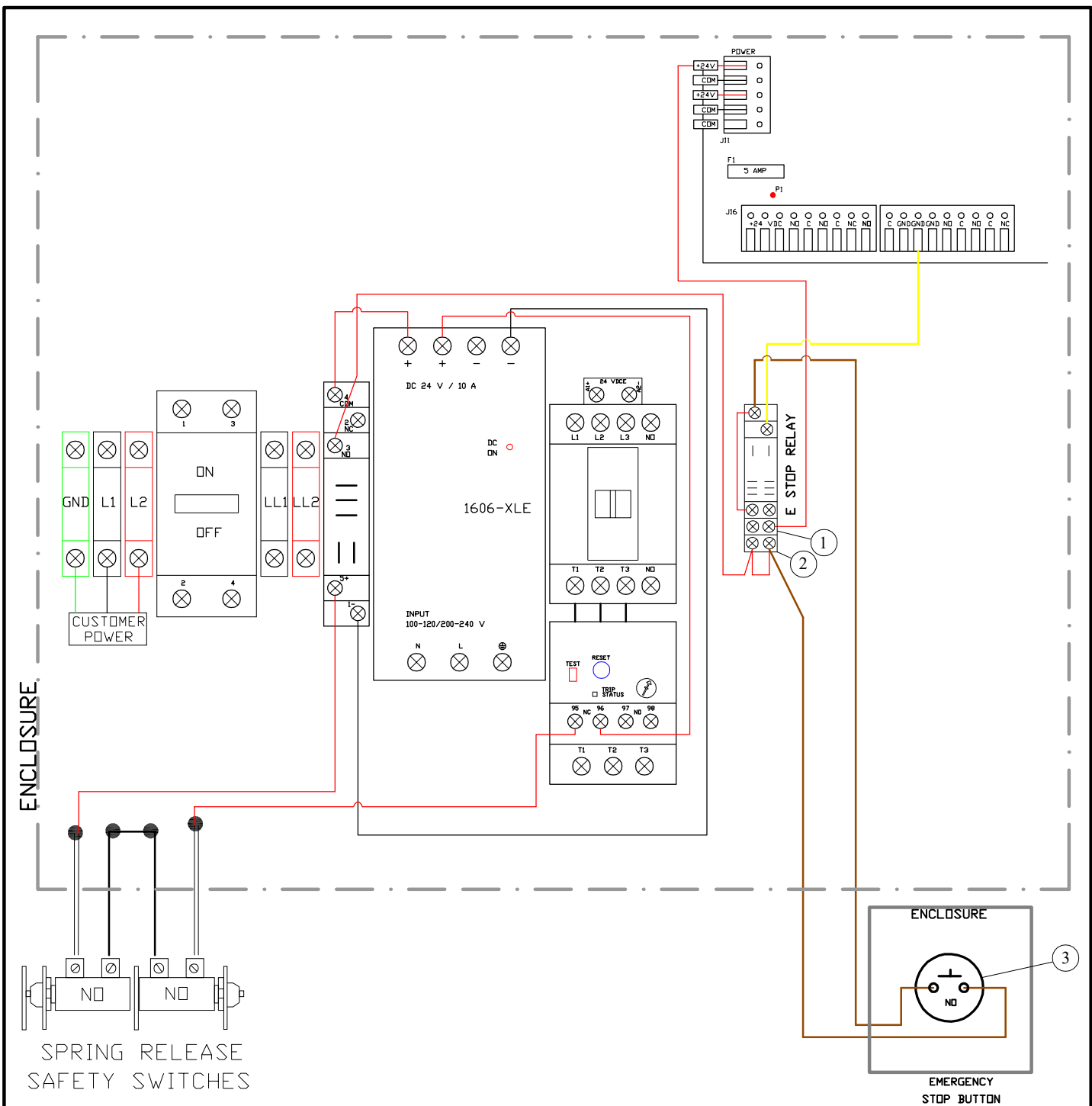

### TILT-A-WAY HYJG 240 VAC SINGLE PHASE EMERGENCY STOP COMPONENTS

REF. NO.	PART NO.	DESCRIPTION	REQ. NO.
1	PEO678	Relay (not shown)	1
2	PEO606A	Socket, Relay	1
3	PEO257	Emergency Stop Button	1

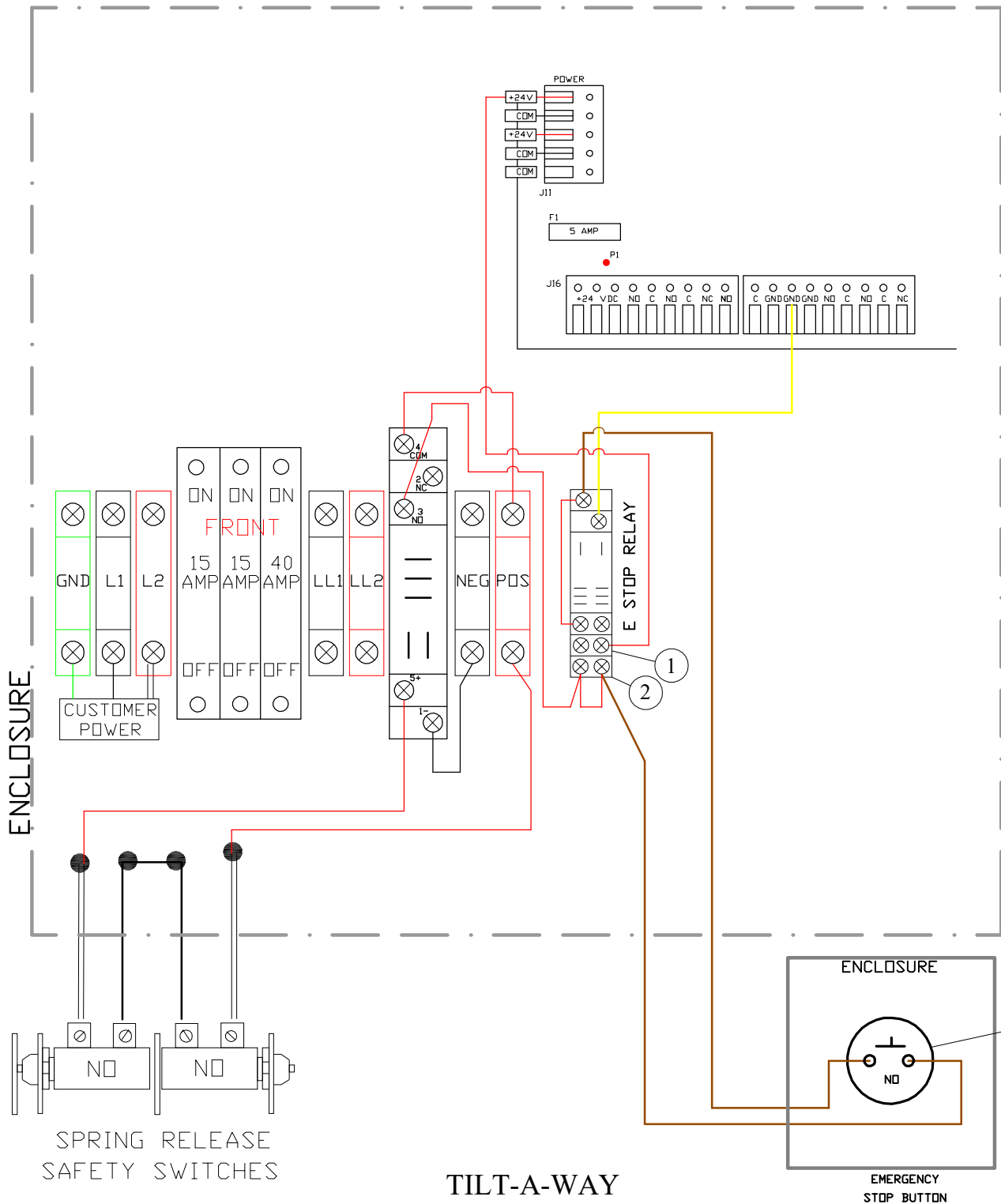

**TILT-A-WAY  
HYJG 24 VDC  
EMERGENCY STOP COMPONENTS**

REF. NO.	PART NO.	DESCRIPTION	REQ. NO.
1	PEO678	Relay (not shown)	1
2	PEO606A	Socket, Relay	1
3	PEO257	Emergency Stop Button	1

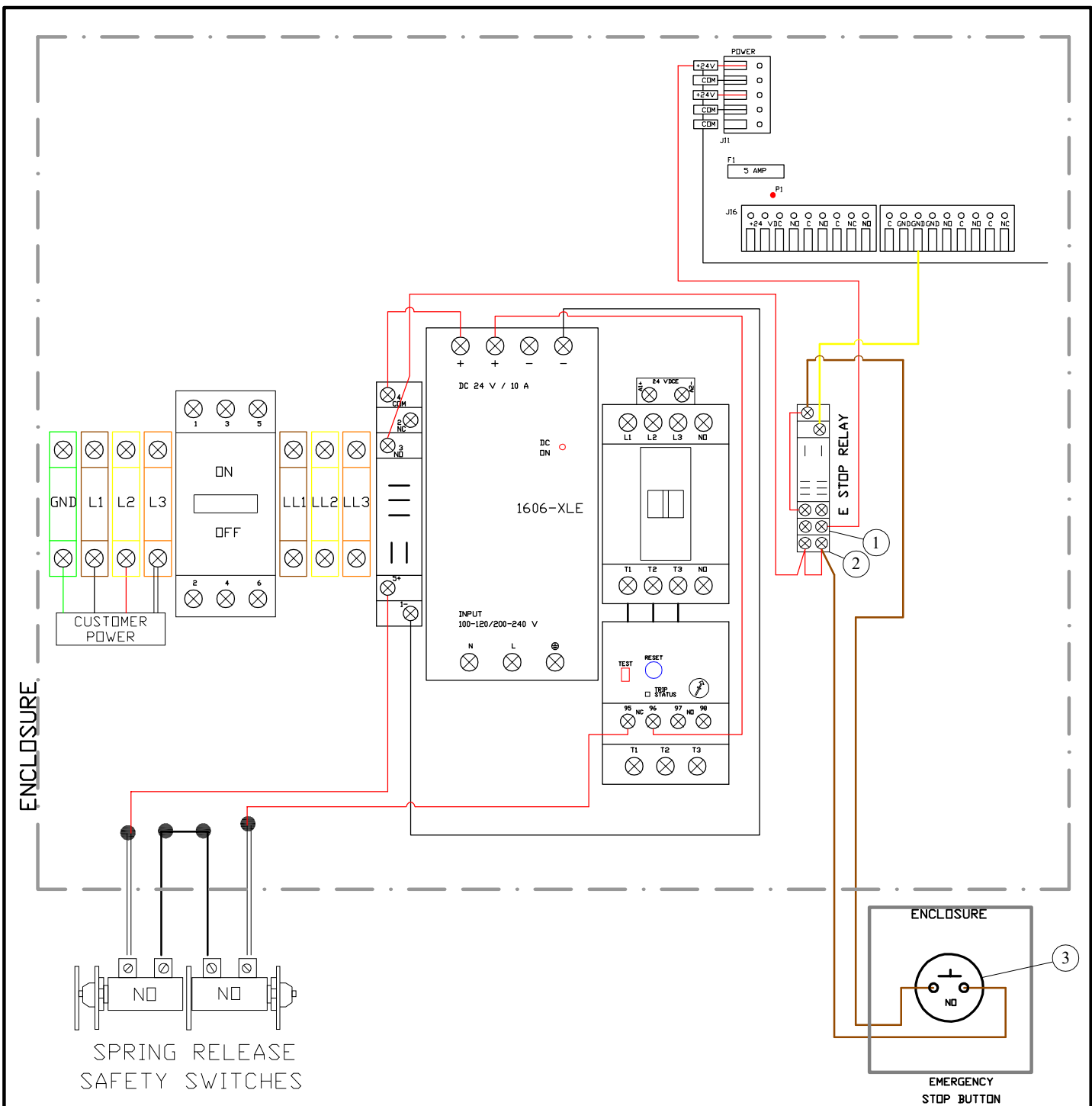

**TILT-A-WAY  
HYJG 240 VAC THREE PHASE  
EMERGENCY STOP COMPONENTS**

REF. NO.	PART NO.	DESCRIPTION	REQ. NO.
1	PEO678	Relay (not shown)	1
2	PEO606A	Socket, Relay	1
3	PEO257	Emergency Stop Button	1



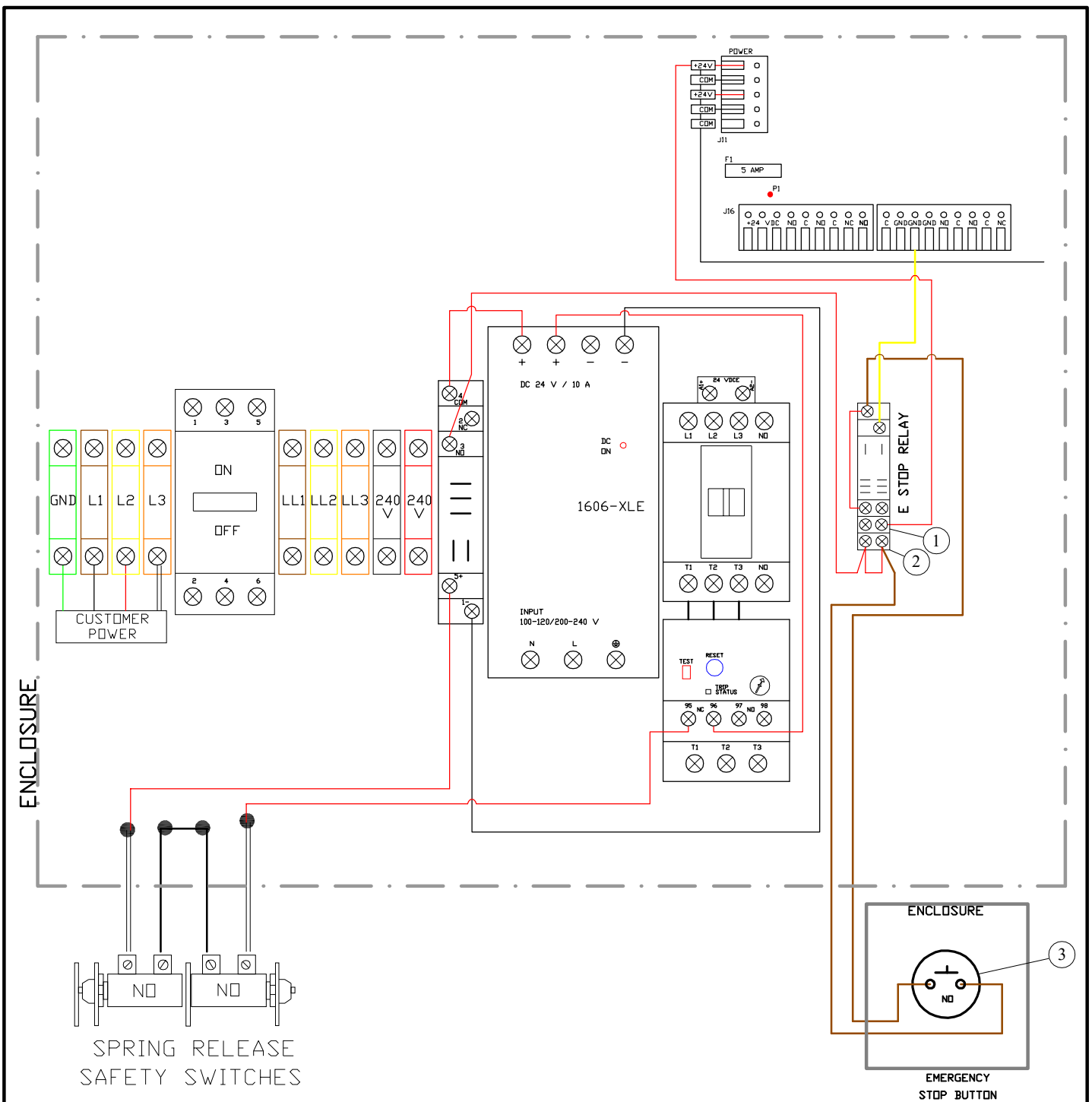

### TILT-A-WAY HYJG 480 VAC THREE PHASE EMERGENCY STOP COMPONENTS

REF. NO.	PART NO.	DESCRIPTION	REQ. NO.
1	PEO678	Relay (not shown)	1
2	PEO606A	Socket, Relay	1
3	PEO257	Emergency Stop Button	1

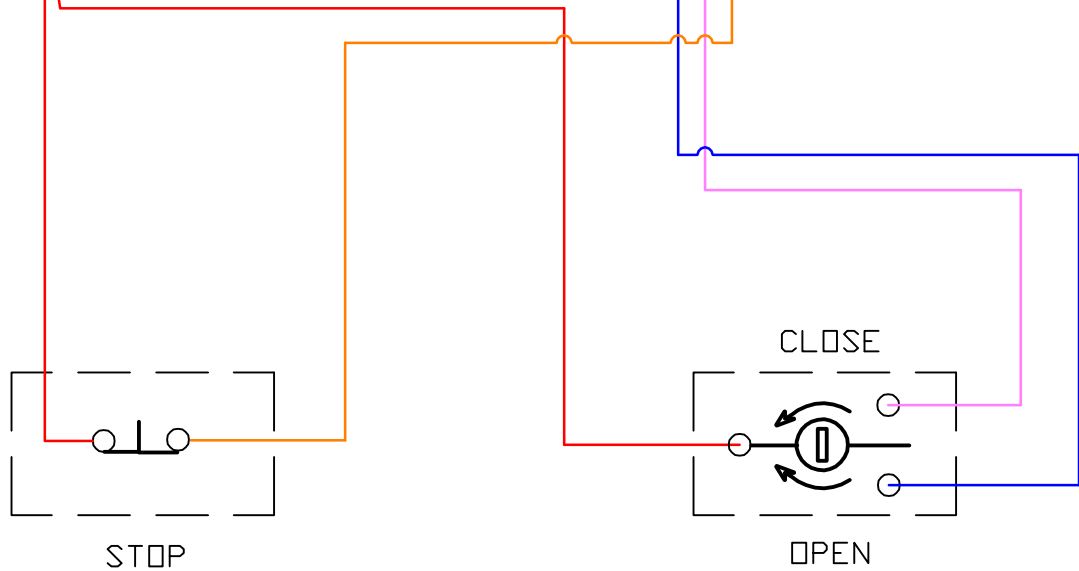
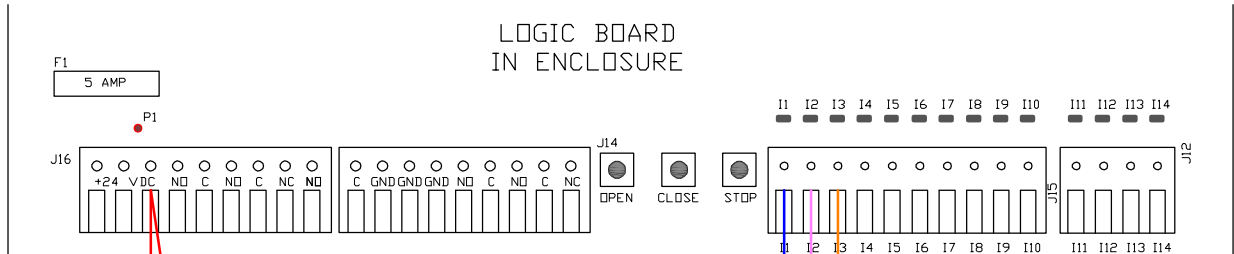

STOP P.B.  
IF OTHER PUSH BUTTON  
STATIONS ARE BEING USED,  
WIRE IN SERIES

OPEN  
MANUAL  
KEY SWITCH

**TILT-A-WAY HYJG 1  
MANUAL KEY SWITCH**

PART NO	DESCRIPTION	REQ NO
PEO263	Manual Key Switch	as req'd

# TILT-A-WAY HYJG 24 VDC GATE OPEN HORN AND LIGHT INDICATOR

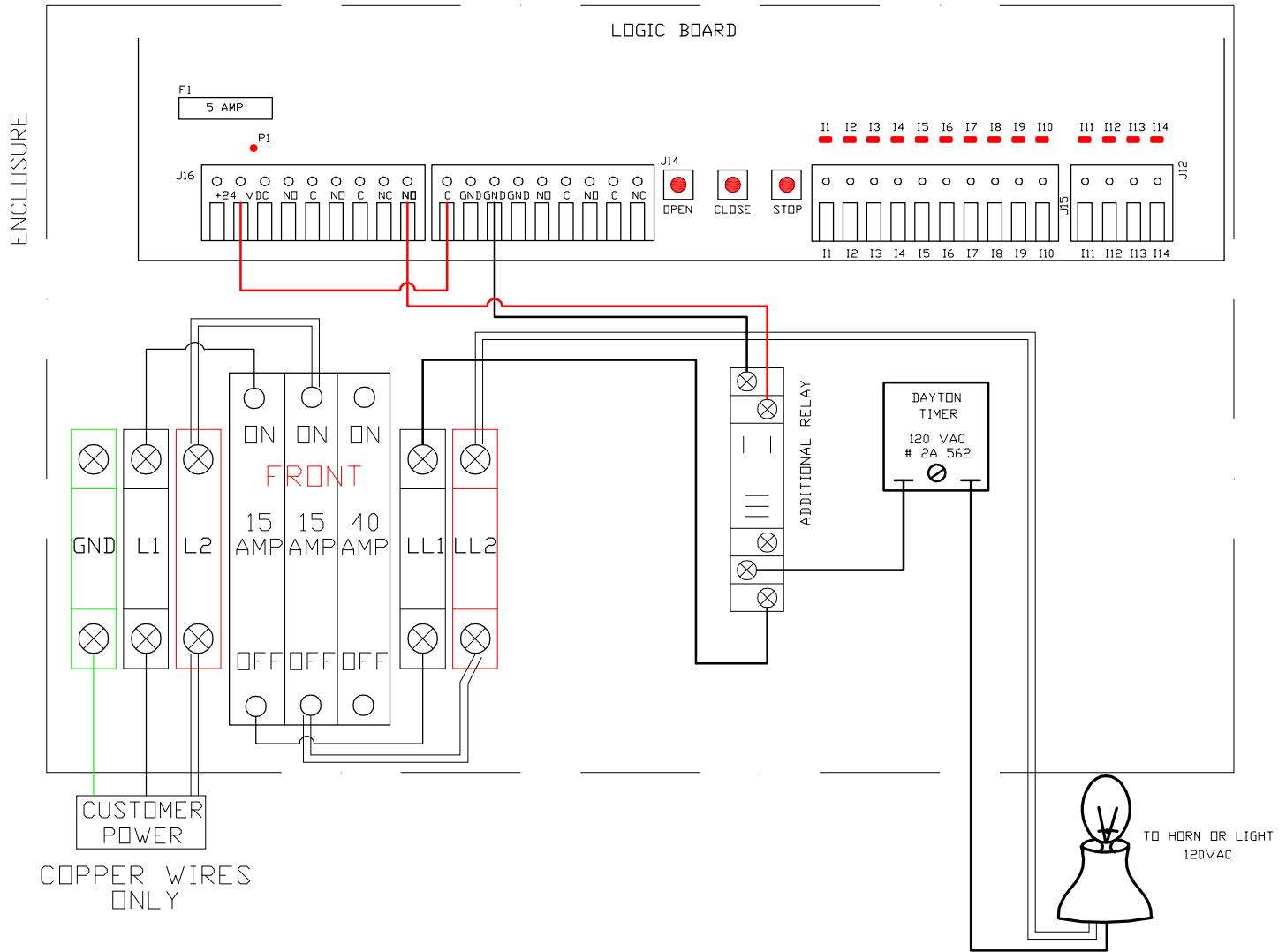

COPPER WIRES ONLY

## TILT-A-WAY HYJG

THE ADDITIONAL RELAY IS CONNECTED TO THE NORMALLY OPEN CONTACTS OF AUXILIARY OUTPUT # 1  
THE OUTPUT FUNCTIONS FOR AUXILIARY OUTPUT # 1 WILL NEED TO BE SET AS FOLLOVED  
PRESS AND HOLD BUTTON SW2 ON THE INTERFACE BOARD UNTIL THE DISPLAY CHANGES  
RELEASE THE SW2 BUTTON AND THE DISPLAY WILL SHOW

### MAIN MENU

UP / DOWN - VIEW MENUS

SELECT - VIEW / EDIT

RESET - EXIT

PRESS AND RELEASE BUTTON SW4 UNTIL THE DISPLAY SHOWS

**TIMING AND OPTIONS**

PRESS AND RELEASE BUTTON SW1 TO ENTER THE MENU

PRESS AND RELEASE BUTTON SW4 UNTIL THE DISPLAY SHOWS

**AUXILIARY I / O**

PRESS AND RELEASE BUTTON SW1 TO ENTER THE SUBMENU

PRESS AND RELEASE BUTTON SW4 UNTIL THE DISPLAY SHOWS

**AUXILIARY OUTPUT # 1 FUNCTION**

PRESS AND RELEASE BUTTON SW1 TO ENTER THE SUBMENU

PRESS AND RELEASE BUTTON SW4 UNTIL THE DISPLAY SHOWS

**HOLD AUX RELAY ON CLOSE LIMIT SWITCH**

PRESS AND RELEASE BUTTON SW1 TO SAVE SELECTION

PRESS AND RELEASE BUTTON SW2 UNTIL YOU HAVE EXITED ALL MENUS

REF NO.	PART NO.	DESCRIPTION	REQ NO
1	PEO284	Delay Timer	1
2	PEO605A	Socket, Relay	1
3	PEO679	Relay	1
		Vehicle Indicator Light ( supplied by customer)	

# TILT-A-WAY HYJG 240 VAC SINGLE PHASE GATE OPEN HORN AND LIGHT INDICATOR

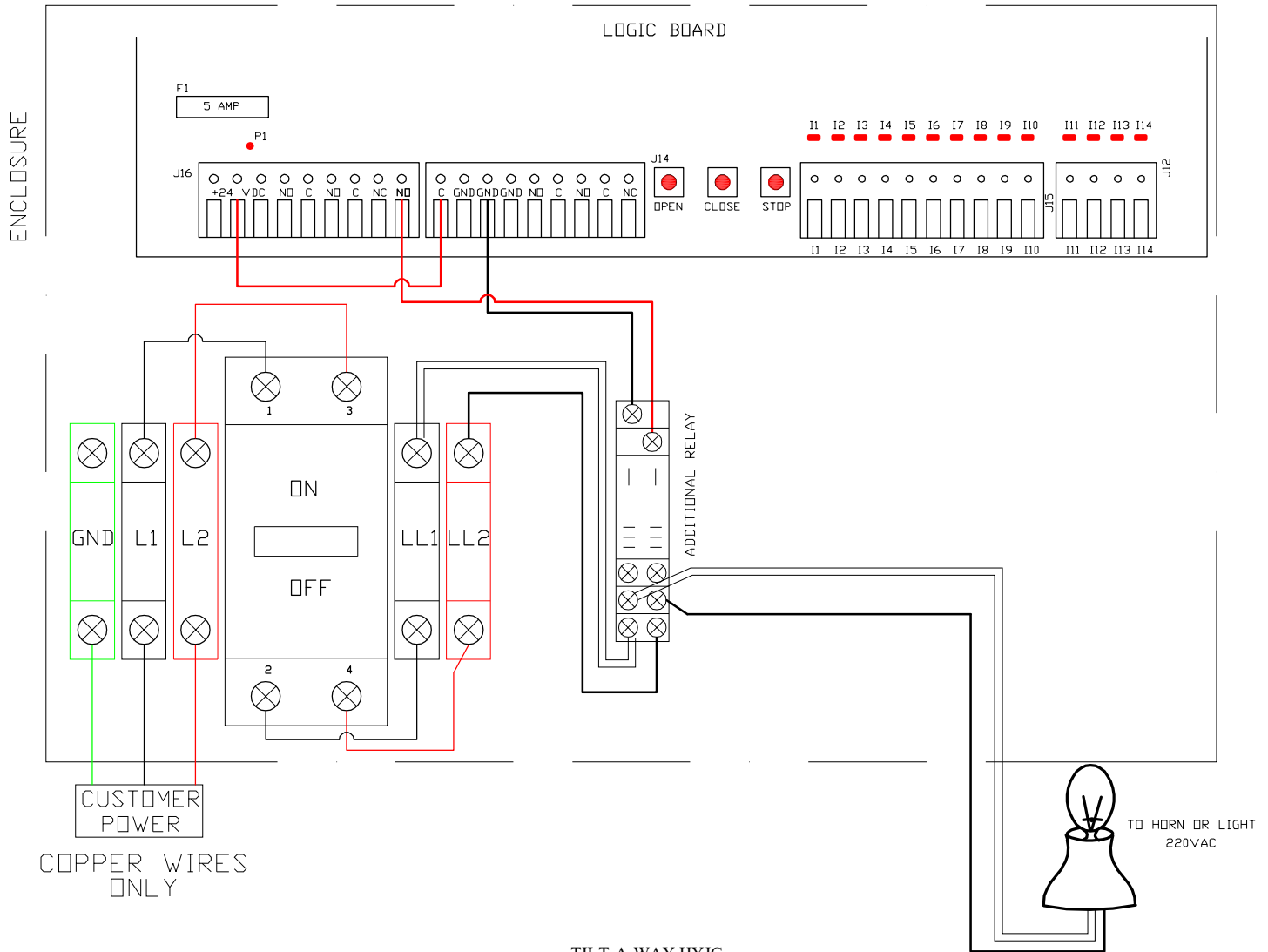

COPPER WIRES ONLY

TILT-A-WAY HYJG  
THE ADDITIONAL RELAY IS CONNECTED TO THE NORMALLY OPEN CONTACTS OF AUXILIARY OUTPUT # 1  
THE OUTPUT FUNCTIONS FOR AUXILIARY OUTPUT # 1 WILL NEED TO BE SET AS FOLLOWED  
PRESS AND HOLD BUTTON SW2 ON THE INTERFACE BOARD UNTIL THE DISPLAY CHANGES  
RELEASE THE SW2 BUTTON AND THE DISPLAY WILL SHOW

**MAIN MENU**

**UP / DOWN - VIEW MENUS**

**SELECT - VIEW / EDIT**

**RESET - EXIT**

PRESS AND RELEASE BUTTON SW4 UNTIL THE DISPLAY SHOWS

**TIMING AND OPTIONS**

PRESS AND RELEASE BUTTON SW1 TO ENTER THE MENU

PRESS AND RELEASE BUTTON SW4 UNTIL THE DISPLAY SHOWS

**AUXILIARY I / O**

PRESS AND RELEASE BUTTON SW1 TO ENTER THE SUBMENU

PRESS AND RELEASE BUTTON SW4 UNTIL THE DISPLAY SHOWS

**AUXILIARY OUTPUT # 1 FUNCTION**

PRESS AND RELEASE BUTTON SW1 TO ENTER THE SUBMENU

PRESS AND RELEASE BUTTON SW4 UNTIL THE DISPLAY SHOWS

**HOLD AUX RELAY ON CLOSE LIMIT SWITCH**

PRESS AND RELEASE BUTTON SW1 TO SAVE SELECTION

PRESS AND RELEASE BUTTON SW2 UNTIL YOU HAVE EXITED ALL MENUS

REF NO.	PART NO.	DESCRIPTION	REQ NO
1	PEO606A	Socket, Relay	1
2	PEO678	Relay	1
3		Vehicle Indicator Light ( supplied by customer)	1

# TILT-A-WAY HYJG 240 VAC THREE PHASE GATE OPEN HORN AND LIGHT INDICATOR

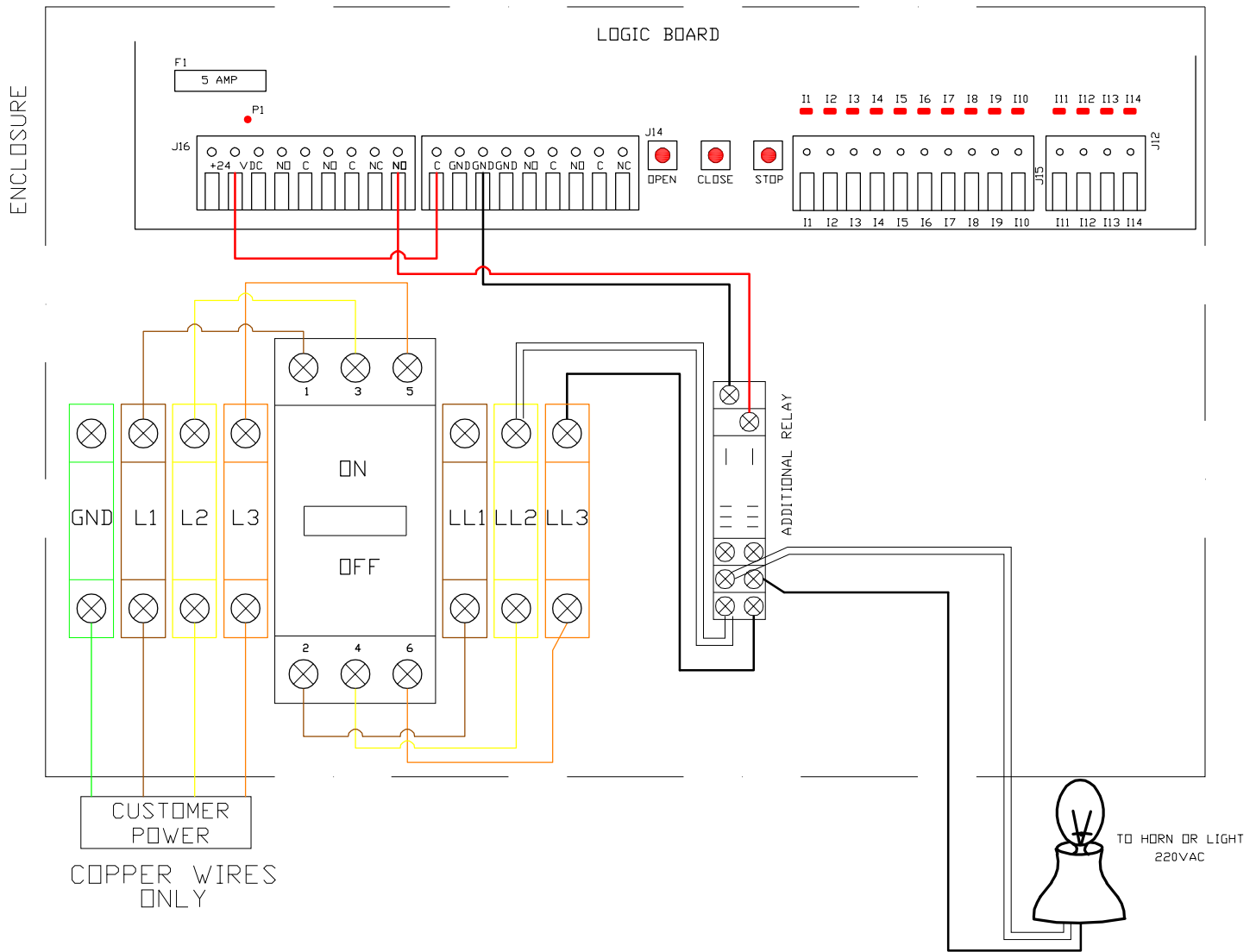

TILT-A-WAY HYJG  
THE ADDITIONAL RELAY IS CONNECTED TO THE NORMALLY OPEN CONTACTS OF AUXILIARY OUTPUT # 1  
THE OUTPUT FUNCTIONS FOR AUXILIARY OUTPUT # 1 WILL NEED TO BE SET AS FOLLOVED  
PRESS AND HOLD BUTTON SW2 ON THE INTERFACE BOARD UNTIL THE DISPLAY CHANGES  
RELEASE THE SW2 BUTTON AND THE DISPLAY WILL SHOW

**MAIN MENU**

**UP / DOWN - VIEW MENUS**

**SELECT - VIEW / EDIT**

**RESET - EXIT**

PRESS AND RELEASE BUTTON SW4 UNTIL THE DISPLAY SHOWS

**TIMING AND OPTIONS**

PRESS AND RELEASE BUTTON SW1 TO ENTER THE MENU

PRESS AND RELEASE BUTTON SW4 UNTIL THE DISPLAY SHOWS

**AUXILIARY I / O**

PRESS AND RELEASE BUTTON SW1 TO ENTER THE SUBMENU

PRESS AND RELEASE BUTTON SW4 UNTIL THE DISPLAY SHOWS

**AUXILIARY OUTPUT # 1 FUNCTION**

PRESS AND RELEASE BUTTON SW1 TO ENTER THE SUBMENU

PRESS AND RELEASE BUTTON SW4 UNTIL THE DISPLAY SHOWS

**HOLD AUX RELAY ON CLOSE LIMIT SWITCH**

PRESS AND RELEASE BUTTON SW1 TO SAVE SELECTION

PRESS AND RELEASE BUTTON SW2 UNTIL YOU HAVE EXITED ALL MENUS

REF NO.	PART NO.	DESCRIPTION	REQ NO
1	PEO606A	Socket, Relay	1
2	PEO678	Relay	1
3		Vehicle Indiacator Light ( supplied by customer)	1

# TILT-A-WAY HYJG 480 VAC THREE PHASE GATE OPEN HORN AND LIGHT INDICATOR

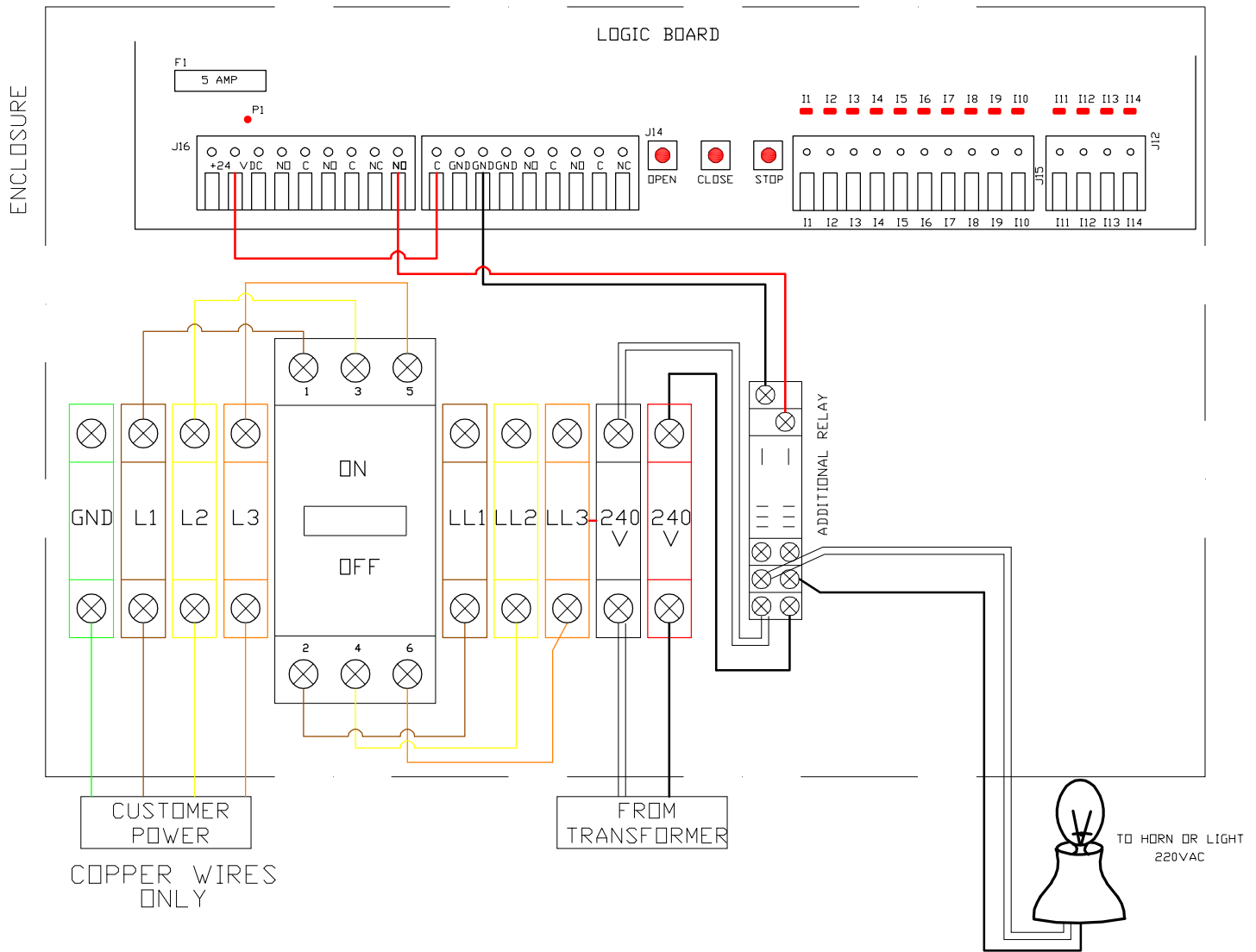

TILT-A-WAY HYJG  
THE ADDITIONAL RELAY IS CONNECTED TO THE NORMALLY OPEN CONTACTS OF AUXILIARY OUTPUT # 1  
THE OUTPUT FUNCTIONS FOR AUXILIARY OUTPUT # 1 WILL NEED TO BE SET AS FOLLOED  
PRESS AND HOLD BUTTON SW2 ON THE INTERFACE BOARD UNTIL THE DISPLAY CHANGES  
RELEASE THE SW2 BUTTON AND THE DISPLAY WILL SHOW

**MAIN MENU**

**UP / DOWN - VIEW MENUS**

**SELECT - VIEW / EDIT**

**RESET - EXIT**

PRESS AND RELEASE BUTTON SW4 UNTIL THE DISPLAY SHOWS

**TIMING AND OPTIONS**

PRESS AND RELEASE BUTTON SW1 TO ENTER THE MENU

PRESS AND RELEASE BUTTON SW4 UNTIL THE DISPLAY SHOWS

**AUXILIARY I / O**

PRESS AND RELEASE BUTTON SW1 TO ENTER THE SUBMENU

PRESS AND RELEASE BUTTON SW4 UNTIL THE DISPLAY SHOWS

**AUXILIARY OUTPUT # 1 FUNCTION**

PRESS AND RELEASE BUTTON SW1 TO ENTER THE SUBMENU

PRESS AND RELEASE BUTTON SW4 UNTIL THE DISPLAY SHOWS

**HOLD AUX RELAY ON CLOSE LIMIT SWITCH**

PRESS AND RELEASE BUTTON SW1 TO SAVE SELECTION

PRESS AND RELEASE BUTTON SW2 UNTIL YOU HAVE EXITED ALL MENUS

REF NO.	PART NO.	DESCRIPTION	REQ NO
1	PEO606A	Socket, Relay	1
2	PEO678	Relay	1
3		Vehicle Indiacator Light ( supplied by customer)	1

LOGIC BOARD  
IN ENCLOSURE

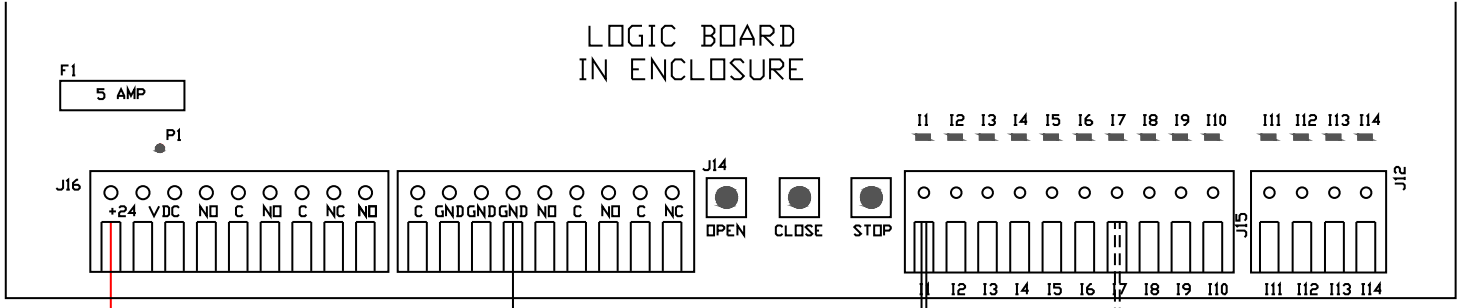

CONNECT TO 11 TO OPEN ONLY  
CONNECT TO 14 TO OPEN  
AND TIME TO CLOSE

NOTE: ALL INPUTS FOR  
FOR HYJG ARE 24 VOLT DC POSITIVE

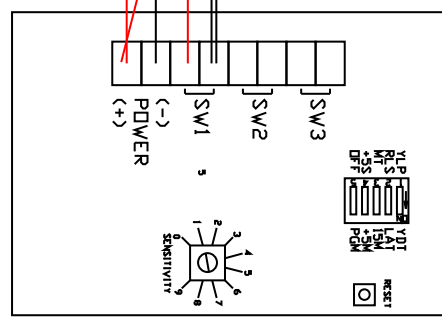

SET ALL DIP SWITCHES  
IN SOS TO OFF TO TEST  
SEE SOS MANUAL  
FOR SETTINGS

SOS ENCLOSURE  
MOUNTED ON THE  
SIDE OF OPERATOR  
PART # PE0403

TILT-A-WAY HYJG 1  
SIREN OPERATED SENSOR  
DC VOLTS AND AC VOLTS SINGLE PHASE AND THREE PHASE

## SOS VIII INSTALLATION AND TESTING INSTRUCTIONS

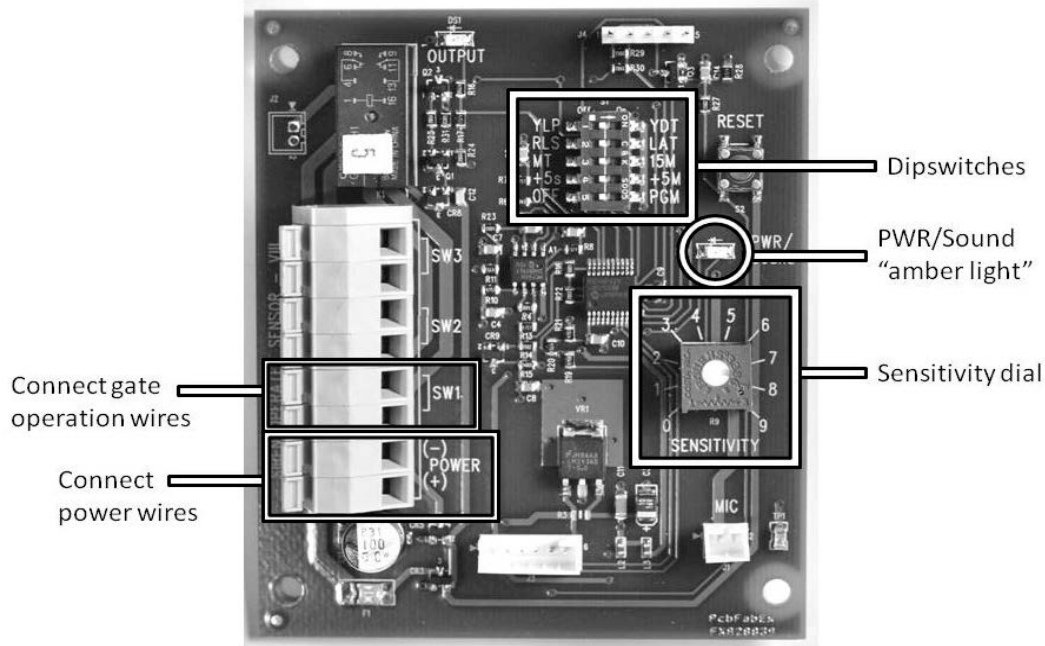

**\*\*\*DRILLING ANY ADDITIONAL HOLES IN THE ENCLOSURE WILL VOID THE WARRANTY!!!**

### Mounting the Unit

1. Remove the face plate of the SOS VIII unit.
2. Identify a location inside the fence to mount the SOS VIII unit. Do not select a location inside the gate operator enclosure or near any noisy machinery that could interfere with the sensor picking up the siren.
3. Using the screws provided, mount the SOS VIII unit with the microphone facing down. The enclosure has four pre-drilled holes for mounting. Drilling any other holes in the enclosure will void the warranty.
4. If using conduit, the large hole in the side of the SOS VIII unit is pre-drilled and tapped to accept a ½" threaded connector. Be sure to use a rubber seal to ensure no water can penetrate. If not using conduit, the small hole in the bottom by the microphone is drilled to accept a 4 conductor cable. Once you have your wire threaded into the unit, be sure to use some silicone around the hole to ensure no water can penetrate. Water damage is not covered under warranty.

**Note:** Drilling any additional holes in the enclosure, indications of damage during installation, or indications of water or electrical damage is NOT covered under the warranty. If mounting the SOS onto metal, do not allow drilled metal pieces to collect onto the magnetic field that is present around the back side of the microphone.

### Connecting the Power and Gate Operator

5. Run 22 AWG stranded wire (not included) from a power source such as the gate operator unit or a battery. The power can be 9 to 30 volts, AC or DC.
6. Press down firmly on the orange levers above the power receptacles and insert the wire. Once power is connected the Power/Sound – amber light LED will blink every 10 seconds.
7. Run two 22 AWG stranded wires from the gate operator unit – one from the COM ("common") terminal and one from the NO ("open") terminal.
8. Before connecting the wires to the SOS unit, test the gate by touching the two wires together. The gate should open.
9. If the gate opens, press down firmly on the orange levers above the SW1 receptacles and insert the wires.



## Testing the Unit

---

Properly testing the unit involves two sensitivity tests: a CD test and a live siren test. SOS recommends keeping the sensitivity at the lowest setting that will still trigger the gate.

10. Begin the CD test by turning the sensitivity dial clockwise to setting 9 (maximum sensitivity).
11. Using the Yelp Siren CD provided, test the sensor with a portable CD player at the loudest setting. Hold the portable CD player close to the microphone located on the bottom of the unit. The gate should open within 2.5 seconds. In the absence of the CD, go to our website at [www.sosgate.com](http://www.sosgate.com) to download a yelp sound and burn it to a CD.
12. Next, begin the live siren test by turning the sensitivity dial down to 7.
13. Have an emergency responder run their yelp siren for up to 10 seconds or until the gate is triggered. If the gate does not open, increase the sensitivity and test again. **Note:** Every time the siren is interrupted or changed the digital processor begins the process over again, so it is best to leave the siren on until the gate triggers.
14. Lastly, have the emergency responder drive past the gate on the road with their yelp siren on. This is to ensure the sensitivity is not too high so as to prompt the gate to false trigger at the sound of a passing emergency responder. Adjust the sensitivity dial as needed.

**SOS recommends inviting an emergency responder out once every 3-4 months to help you conduct a live siren test. This will ensure the unit remains in good working order. Most emergency responders will gladly perform this service but it is the gate owner's responsibility to invite them.**

## Adjusting Dipswitch Settings

---

**Dipswitch 1:** When this switch is in the YLP position, the sensor will detect only a "yelp" siren and will open the gate after a valid signal has been detected for 2.5 seconds. When the switch is in the YDT position, the sensor will open the gate once it has detected any siren or any continuous loud noise (such as a loud engine) for 4.5 seconds. To avoid false triggers, SOS suggests keeping this switch in the YLP position.

**Dipswitch 2:** When this switch is in the RLS position, the sensor will not interfere with the gate's normal closure time. When the switch is in the LAT position, the gate will remain open until the reset button is pushed or power is recycled. This will override any other programming for closing times and the gate will remain open until it is reset. There is a reset button on the outside of the enclosure.

**Dipswitch 3:** When this switch is in the MT position, the sensor will not interfere with the gate's normal closure time. When the switch is set to 15M, the gate will remain open for 15 minutes unless it has been programmed for a different time setting with dipswitches 4 and 5. **Note:** When switch #2 is in the LAT position, the settings for dipswitch #3 are irrelevant.

**Dipswitch 4:** This switch allows you to keep the gate open for a preset time other than the factory settings of "normal", "15 minutes", and "latch open." When this switch is set to +5S, each press of the reset button will add an additional 5 seconds the gate will remain open. When the switch is set to +5M, each press of the reset button will add an additional 5 minutes the gate will remain open. **Note:** For dipswitch #4 settings to take effect, make sure dipswitch #2 is in the RLS position and dipswitch #3 is in the 15M position.

**Dipswitch 5:** When this switch is in the OFF position, pressing the reset button will not change any of the time settings for leaving the gate open. When this switch is in the PGM position, it is in program mode and every push of the reset button will add 5 seconds or 5 minutes (depending on dipswitch 4's setting) to the time the gate remains open up to a maximum of 120 minutes. \*Be sure to move switch back into the off position once you have completed the programming.

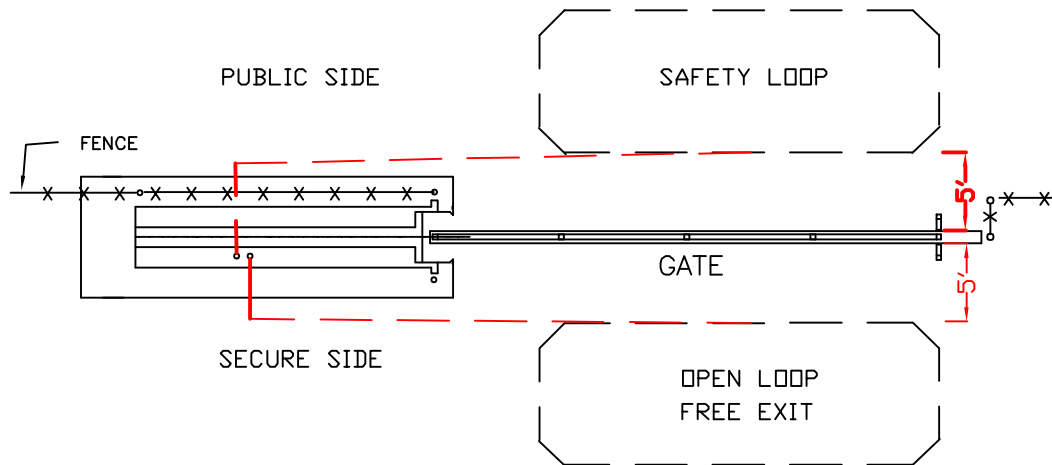

NOTE: MAKE LOOPS APPROPRIATE FOR ROADWAY AND SET BACK FROM GATE BARRIER 5 FEET

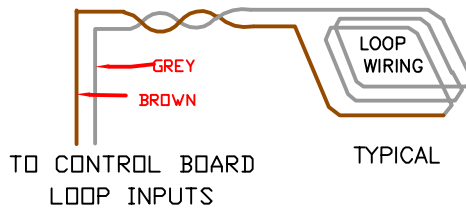

NOTE:

Lead wires from more than one loop installation may be routed in same conduit if wires from each individual loop are twisted at least 6 turns per 12 inches.

### TILT-A-WAY HYJG 1 ELECTRICAL LOOP WIRING



# ULT-PLG

## ULTRALOOP

# Vehicle Loop Detector



CE

# Operating Instructions

---

## CAUTIONS AND WARNINGS

---



*CE REQUIREMENT: Use EMX Pre-formed loops with built-in surge suppression for CE compliance. Connect shield on lead in wire to earth ground.*

*CE REQUIREMENT: Use CE rated power supply for CE compliance providing suppression as specified by EN61000-4-5.*

*Not to be used in safety applications.*

*When more than one loop detector is used, set each one to a different frequency.*

*Refer to DIP switch diagram for frequency settings.*

### IMPORTANT:

This product is an accessory or part of a system. Always read and follow the manufacturer's instructions for the equipment before connecting this product. Comply with all applicable codes and safety regulations. Failure to do so may result in damage, injury or death.

---

## PRODUCT OVERVIEW

---

The ULT-PLG vehicle loop detector is compatible with most gate operators. The ULT-PLG may be used in Center, Safety and Exit loop positions. The UltraMETER™ display feature makes set-up easy by displaying the optimum sensitivity setting required to detect a vehicle positioned on the loop. Ten sensitivity settings allow for fine adjustment of detection level. The Detect On Stop (DOS®) feature allows detection only when a vehicle has come to a complete stop. Output B switch allows configuration of output 2 for FAIL, PULSE ON ENTRY, PULSE ON EXIT, or SAME AS OUPUT A. Four frequency settings provide flexibility in preventing crosstalk in multi-loop applications.

The ULT-PLG is compatible with a wide variety of gate operators including:

- Advanced Access Automation/FAAC CSL2000, CSW2000, RSW1000
- All-O-Matic SL100-DC
- Apollo 4300, 4500
- Chamberlain/Elite SL3000,CSW200
- Intelligate Systems IQ500, IQ5000
- Linear (OSCO) with APeX controller
- PowerMaster operators with PowerMaster controllers
- Rotary Gate Systems models SL1000C, SL1000I, SL1000R
- SECOM Late model operators with 10 pin Molex connectors
- TyMetal TYM 1000, TYM 2000
- Viking Access Models L-3, F-1, T-21, H-10, B-12, Q-4

## Specifications

Sensitivity	10 levels, 0-9
UltraMETER™ Display	Indicates optimum sensitivity level, 0-9 Diagnostic aid
Loop frequency	4 settings (low, med-low, med-hi, high)
Loop inductance	20...2000μH (Q factor ≥ 5)
Grounded loop	Isolation transformer allows operation with poor quality loops
Automatic tuning	Detector tunes to loop on power-up and following frequency count function
Environmental tracking	Automatic compensation
Surge protection	Loop circuitry protected by surge suppressors
Detect output	Solid-state
Output B	Solid state
Output B inverted	Solid state
Power / loop fault indicator	Green LED
Detect / frequency count indicator	Red LED
ASB (Automatic Sensitivity Boost)	Increases sensitivity after initial detection to prevent dropout due to high-bed vehicles
Power	12VDC...24VDC (see Cautions and Warnings)
Operating Current	15 mA
Operating temperature	-40°C...82°C (-40°F...180°F) 0...95% relative humidity
Dimensions (L x W x H)	3.0"(76mm) x 0.9"(22mm) x 2.75"(70mm)
Weight	0.15 lbs. (68 g)
Connector	10-pin female



---

# OPERATION

---

## Power up

Upon power up the detector initializes by automatically tuning to the loop. The green LED indicates that the detector is powered and operational.

## Frequency setting

The operating frequency of the loop is a function of the specific loop inductance and DIP switch settings 1 and 2. The primary purpose of the frequency setting is to allow the installer the ability to set different operating frequencies for multi-loop installations, recommended to prevent crosstalk/interference from adjacent loops. After changing the frequency setting, press the Frequency Count switch to re-initialize the detector. To check the operating frequency of a loop refer to the Frequency Count section. To determine whether crosstalk between adjacent loops is occurring, refer to the UltraMETER Sensitivity Display section.

## UltraMETER™ Sensitivity Display

The UltraMETER™ sensitivity display simplifies the installation process by displaying the sensitivity setting required to detect a vehicle on the loop. To use this feature, observe the display while a vehicle is moving into position on the loop, note the number displayed, then adjust the sensitivity setting (rotary switch) to the displayed position.

During normal operation, when a vehicle is not on the loop, the display is blank. The effects of crosstalk or other interference can be observed on the display when the loop is vacant. Interference or crosstalk will cause the display to indicate a level, typically 8 or 9. It may be necessary to observe the display for a minute or so to see this effect. Change the frequency setting to prevent crosstalk.

## Sensitivity setting

The 10-position rotary switch allows for precise adjustment of detection level. The sensitivity level increases from position 0 thru 9 with position 0 being the lowest sensitivity. Typical applications require a setting of 3 or 4. The UltraMETER™ sensitivity display simplifies the installation process by displaying the sensitivity setting required to detect a vehicle on the loop. To use this feature, observe the display while a vehicle is moving into position on the loop, note the number displayed, then adjust the sensitivity setting (rotary switch) to the displayed position.

## Frequency Count / Reset

Press the Frequency Count switch and count the number of flashes on the red LED. Each flash represents 10kHz. To help to prevent crosstalk when multiple detectors are used for adjacent loops, perform a frequency count on each detector to confirm the operation frequencies are different. Following a frequency count cycle, the detector re-initializes

## Automatic Sensitivity Boost

The Automatic Sensitivity Boost causes the sensitivity to increase following initial detection. This feature is useful to prevent dropout when detecting high-bed vehicles. The sensitivity returns to its normal setting after the vehicle exits the loop. Decimal point on the display indicates ASB on.

## Presence output

The Presence settings provides two selections, the output can be set for Infinite Presence or Normal Presence. Infinite Presence causes the output to remain in detect mode as long as the vehicle remains on the loop. Normal Presence causes the output to reset after 5 minutes. **DO NOT USE THE NORMAL PRESENCE SETTING UNLESS THE OPENING IS PROTECTED BY A SECONDARY SAFETY DEVICE SUCH AS THE IRB-4X.**

## Detect-on-stop (DOS™)

The detect-on-stop affects B and /B (inverted B output). This function requires that a vehicle come to a complete stop on the loop for the output to activate. This feature is useful in cases where cross-traffic causes the detection.

## Output B

Output B settings allow Pulse on Entry, Pulse on Exit, Output B same as Presence and Loop Fault.

## Fail Safe / Fail Secure

Fail Safe setting causes the ULT-PLG to activate the Presence output in the event a loop failure. Fail Secure setting will cause the ULT-PLG not to activate the Presence output in the event a loop failure.

# Controls and Indicators

## AUTOMATIC SENSITIVITY BOOST

	DIP switch position 8
ASB enabled	on
ASB off	off

## PRESENCE

	DIP switch position 7
NORMAL	on
INFINITE	off

## DETECT-ON-STOP (DOS)

	DIP switch position 6
DOS on	on
DOS off	off

## OUTPUT B

MODE	DIP switch position	
	4	5
Pulse on Entry	on	on
Pulse on Exit (1)	off	on
B same as A	on	off
Loop Fault	off	Off

(1) Not used when DOS is selected

## FAIL SAFE / SECURE

	DIP switch position 3
Fail Secure	on
Fail Safe	off

## FREQUENCY SETTINGS

FREQUENCY	DIP switch position	
	2	1
Low	on	on
Medium low	on	off
Medium high	off	on
High	off	off

## SENSITIVITY SETTING

Sensitivity	Position 0.....9
	Low.....high

## DETECT / FREQUENCY COUNT

	Red LED
Presence detected	on
No presence	off
Frequency count	flashing

## ULTRAMETER™ DISPLAY

Indicates sensitivity setting required to detect vehicle.

## FREQUENCY COUNT / RESET

Press to start frequency count, re-initializes after count





## Connections

Connector pin	Description
1	Loop
2	Loop
3	Power + (12VDC...24VDC)
4	No connection
5	No connection
6	Output B
7	Output B inverted
8	Presence output
9	Power + (12VDC...24VDC)
10	Common

## Troubleshooting

Symptom	Possible cause	Solution
Green LED flashes	Loop wire shorted or open	Check loop resistance on the appropriate loop pins on the control board connector, between .5 ohms and 5 ohms.
Green LED flashes, 2 fast	Loop was previously shorted or open	Check loop resistance on the appropriate loop pins on the control board connector.
Detector remains in detect after vehicle has left loop	<ol style="list-style-type: none"> <li>1. Faulty loop</li> <li>2. Poorly crimped terminals</li> <li>3. Loose connections</li> </ol>	<ol style="list-style-type: none"> <li>1. Perform megger test from loop lead to ground, should be &gt;100 megohms</li> <li>2. Check loop connections to terminals</li> <li>3. Check splices are properly soldered and sealed against moisture</li> <li>4. Observe ULTRAMETER display, level indicated on display indicates residual frequency shift from vacant loop to vehicle presence, press Frequency Count switch to re-initialize the detector</li> </ol>
Intermittent detection	<ol style="list-style-type: none"> <li>1. Faulty loop</li> <li>2. Poorly crimped terminals</li> <li>3. Loose connections</li> <li>4. Cross-talk between adjacent loops</li> </ol>	<ol style="list-style-type: none"> <li>1. Perform megger test from loop lead to ground, should be &gt;100 megohms</li> <li>2. Check loop connections to terminals</li> <li>3. Check splices are properly soldered and sealed against moisture</li> <li>4. Set adjacent loops to different frequencies (see Frequency Setting)</li> </ol>
No detection	<ol style="list-style-type: none"> <li>1. Loop wire shorted or open</li> <li>2. Loop sensitivity set too low</li> </ol>	<ol style="list-style-type: none"> <li>1. Check loop resistance on the appropriate loop pins on the control board connector, between .5 ohms and 5 ohms.</li> <li>2. With vehicle on loop, observe ULTRAMETER display, set sensitivity to the level indicated on the display</li> </ol>

---

## Loop Installation

---

### NEW SLAB POUR

Ty-wrap 1-1/4" PVC pipe to the top of the rebar in the size and configuration of the loop (ex. 4' x 8'). Then ty-wrap the loop to the top of the PVC frame. This stabilizes the loop during the pour and separates it from the rebar.

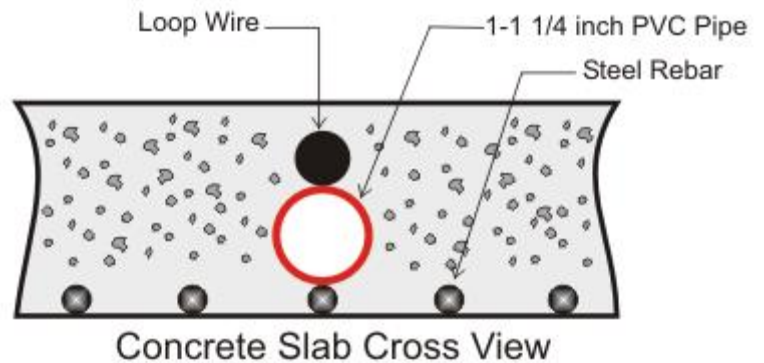

### SAW CUT EXISTING SURFACE

Cut 1" deep into the existing surface, place a 45° cut at the corners to prevent sharp edges from damaging the loop wire. Notch out for the "T" connection where the lead wire connects to the loop. Remove all debris from the finished cut with compressed air. Place the loop into the saw cut. Place backer material into the saw cut over the loop wire and pack tightly. Place a high-quality sealer over the saw cut to seal the surface.

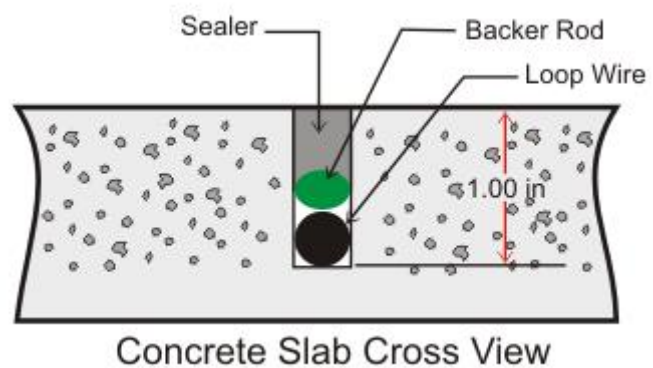

### RESURFACE ASPHALT

Saw cut the existing surface 3/4" deep and place a 45° cut at the corners to prevent sharp edges from damaging the loop wire. Remove all debris from the finished cut with compressed air. Place sand over the loop wire to the surface and pack tightly. Lay new asphalt.

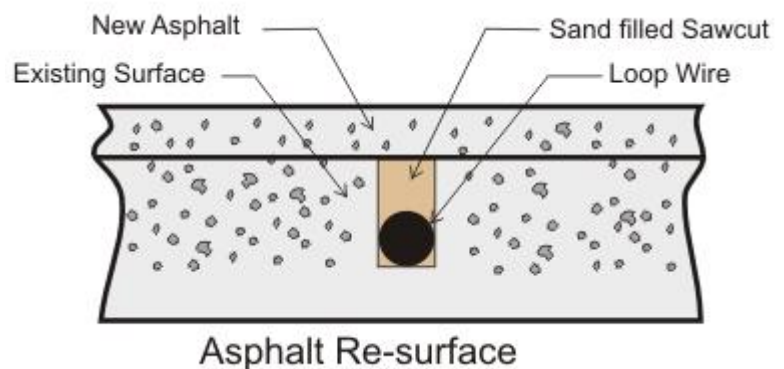

---

## General Installation Guidelines

- Use EMX Lite Preformed loops for quick, reliable installations and for CE compliance.
- Lead-in wire (wire from loop to detector) must be twisted a minimum of 6 turns/ foot to avoid the effects of noise or other interference.
- Detection height is approximately 70% of the shortest side of the loop. Example: detection height for an 4' x 8' loop =  $48" \times .7 = 33.6"$

---

## Ordering information

---

ULT-PLG      ULTRALOOP Vehicle Loop Detector

---

## Accessories

---

PR-XX      EMX Lite Preformed Loops™

---

## Warranty

---

### **WARRANTY**

EMX Industries Incorporated warrants all products to be free of defects in materials and workmanship for a period of two years under normal use and service from the date of sale to our customer. This warranty does not cover normal wear and tear, abuse, misuse, overloading, altered products, damage caused by incorrect connections, lightning damage, or use other than intended design.

There is no warranty of merchantability. There are no warranties expressed or implied or any affirmation of fact or representation except as set forth herein.

EMX Industries Inc. sole responsibility and liability, and the purchaser's exclusive remedy shall be limited to the repair or replacement at EMX Industries option of a part or parts found not conforming to the warranty. In no event shall EMX Industries Inc. be liable for damages of any nature, including incidental or consequential damages, including but not limited to damages resulting from non-conformity, defect in material or workmanship.

*effective date January 1, 2002*



BLANK PAGE

BLANK PAGE



4564 Johnston Parkway  
Cleveland, Ohio 44128  
United States of America  
[www.emxinc.com](http://www.emxinc.com)

Technical Support: (216) 834-0761  
[technical@emxinc.com](mailto:technical@emxinc.com)

Sales: (216) 518-9888  
Fax: (216) 518-9884  
[salesupport@emxinc.com](mailto:salesupport@emxinc.com)



# TILT-A-WAY HYJG 1 LOOP DETECTOR SOCKET DIAGRAM

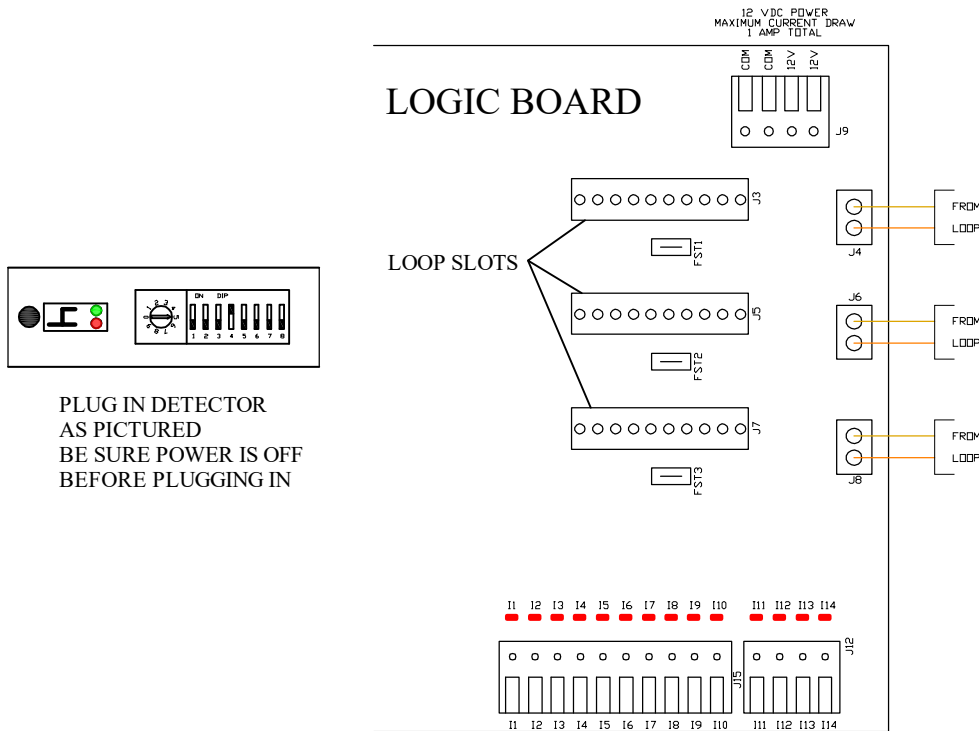

## TILT-A-WAY HYJG

THERE ARE THREE LOOP SLOTS J3, J5, AND J7 THAT CAN BE PROGRAMMED FOR SEVERAL DIFFERENT FUNCTIONS  
LOOP SLOT DISABLED / SAFETY LOOP / FREE EXIT LOOP / SHADOW LOOP / ARMING LOOP  
TO ACCESS THESE FUNCTIONS PRESS AND HOLD BUTTON SW2 ON THE INTERFACE BOARD FOR ABOUT 4 SECONDS  
UNTIL THE DISPLAY CHANGES TO SHOW

### MAIN MENU

UP / DOWN - VIEW MENUS

SELECT - VIEW / EDIT

RESET - EXIT

PRESS AND RELEASE BUTTON SW4 UNTIL THE DISPLAY CHANGES TO

### TIMING AND OPTIONS

PRESS AND RELEASE BUTTON SW1 TO ENTER THIS MENU

PRESS AND RELEASE BUTTON SW4 UNTIL THE DISPLAY SHOWS

### LOOP AND REMOTE ASSIGNMENT

PRESS AND RELEASE BUTTON SW1 TO ENTER SUBMENU

THE DISPLAY WILL SHOW

### LOOP FUNCTIONALITY ASSIGNMENT J3 SLOT

USE BUTTON SW4 TO SCROLL THRU THE SUBMENU UNTIL THE SLOT THAT YOU WANT TO ACCESS IS SHOW

PRESS AND RELEASE BUTTON SW1 TO ENTER

USE BUTTON SW4 TO SCROLL THRU THE FUNCTION ASSIGNMENTS UNTIL THE DESIRE FUNCTION IS SHOW

PRESS AND RELEASE BUTTON SW1 TO SAVE

USE BUTTON SW4 TO CHANGE TO THE NEXT LOOP SLOT TO BE PROGRAMMED AND REPEAT

TO ASSIGN FUNCTIONS TO ALL SLOTS USED

WHEN ALL SLOTS HAVE BEEN PROGRAMMED PRESS AND RELEASE BUTTON SW2 TO EXIT SUBMENU

REPEAT UNTIL YOU HAVE EXITED ALL MENUS

**SAFETY LOOP** WILL STOP AND REVERSE A CLOSING GATE, AND HOLD AN OPEN GATE OPEN UNTIL CLEARED

**FREE EXIT** WILL OPEN A CLOSED GATE AND STOP AND REVERSE A CLOSING GATE AND HOLD IT OPEN UNTIL CLEARED

**SHADOW LOOP** WILL HOLD OPEN A FULLY OPENED GATE UNTIL CLEARED

**ARMING LOOP** WILL LATCH AN AUXILIARY OUTPUT RELAY IF THE AUXILIARY OUTPUT RELAY FUNCTION

**HOLD AUX RELAY ON ARMING LOOP ASSERTION** HAS BEEN SELECTED IN THE **AUXILIARY I / O** SUBMENU IN

**TIMING AND OPTIONS** MENU

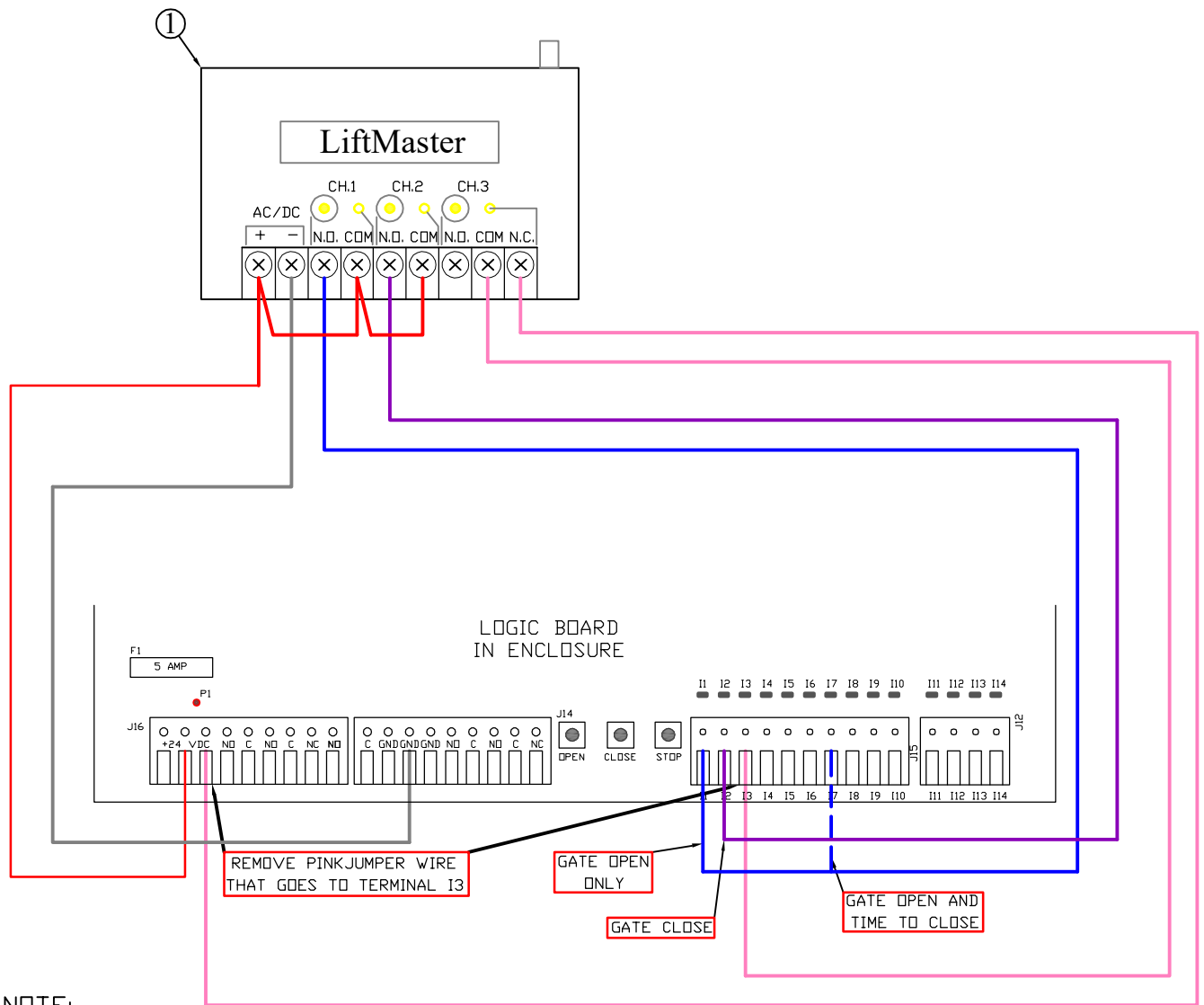

**NOTE:**

ALL STOP CONNECTIONS IN SERIES

STOP CIRCUIT  
ALL STOPS  
MUST BE  
WIRED IN  
SERIES

**TILT-A-WAY HYJG 1  
RADIO RECEIVER - THREE BUTTON**

REF. NO.	PART NO.	DESCRIPTION	REQ. NO.
1	PEO272	Radio Receiver Model 850LM	1
2	PEO273A	Radio Transmitter 1-Button Model 811LM	as req
3	PEO273B	Radio Transmitter 3-Button Model 813LM	as req
4	G00131	Radio Receiver Mounting Plate (not shown)	1



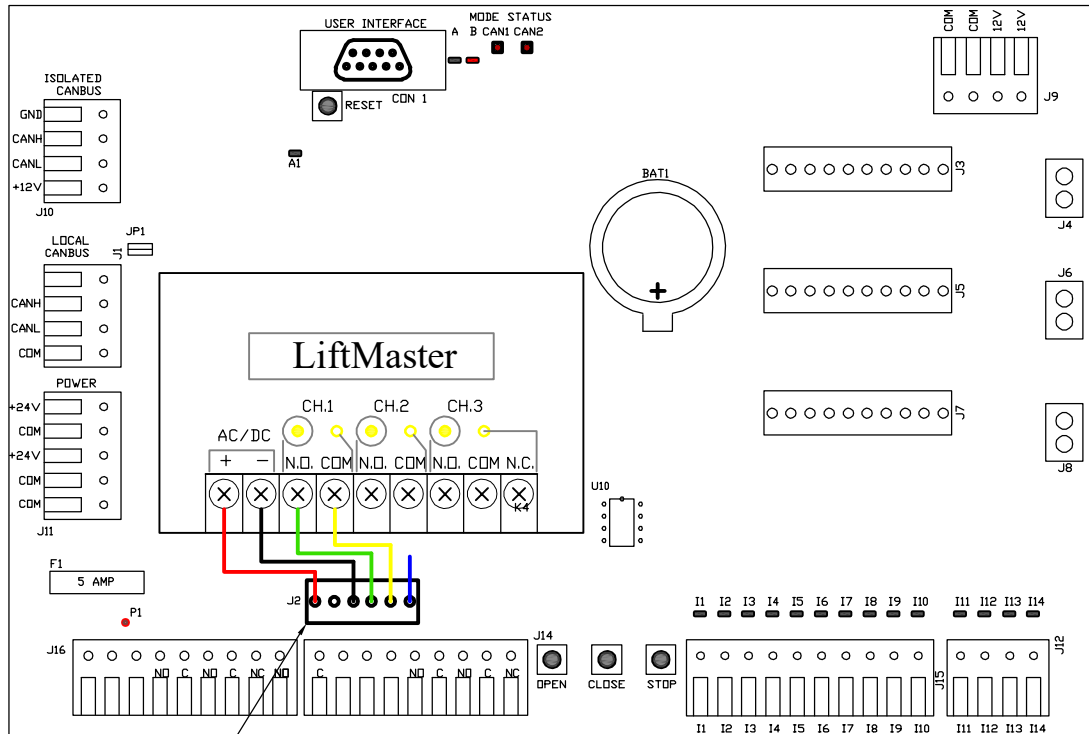

MOUNT TO LOGIC BOARD  
 USING STAND OFFS  
 CUT RED, BLACK, GREEN,  
 AND YELLOW WIRES CLOSE TO  
 WHITE PLUG END.  
 TRIM AND WIRE AS SHOWN.  
 CUT BLUE WIRE CLOSE  
 TO LOGIC BOARD.

### TILT-A-WAY HYJG 1 RADIO RECEIVER - SINGLE BUTTON

REF. NO.	PART NO.	DESCRIPTION	REQ. NO.
1	PEO272	Radio Receiver Model 850LM	1
2	PEO273A	Radio Transmitter 1-Button Model 811LM	as req
3	PEO273B	Radio Transmitter 3-Button Model 813LM	as req
1	G00131	Radio Receiver Mounting Plate (not shown)	1

# LiftMaster®

## 3-CHANNEL UNIVERSAL RECEIVER MODELS 850LM AND 850LMC

### APPLICATION

The receiver can be used as a single or three channel receiver to control up to 3 gates or commercial door operators. The receiver can also be used with a 3-button remote control to operate the OPEN, CLOSE, and STOP feature on a commercial door operator. The receiver is not for use with MyQ™ enabled garage door openers or devices.

Each channel is compatible with a certain number of remote controls and keypads. Refer to the list below:

- CH1: 50 remote controls and 2 keypads
- CH2: 20 remote controls and 2 keypads
- CH3: 20 remote controls and 2 keypads

When the channel has reached full capacity for remote controls, all LEDs will blink 3 times. When the channel has reached full capacity for keypads, all LEDs will blink 4 times. Additional accessories can be programmed, however, the newly programmed accessory will replace the first programmed accessory.

**NOTE** The receiver will only allow you to program a button on the remote control to one channel at a time. For example, if the button on the remote control is already programmed to channel 1 and then is programmed to channel 3, the button will be erased from channel 1 and will only work on channel 3.

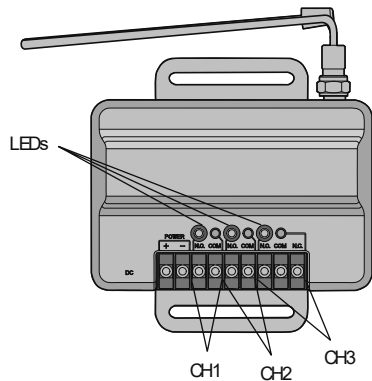

### INSTALLATION

The receiver and antenna use TV Type F coaxial connectors. The antenna can be connected directly to the receiver or it can be installed remotely using a coaxial cable extension kit (Model 86LM, 15 ft. or 86LMT, 25 ft.).

- 1 Select a location for the receiver which allows access to the terminals and space for the antenna. Ensure antenna does not touch metal surfaces. DO NOT bend or fold the antenna.
- 2 Fasten the receiver securely with the hook and loop fasteners (provided) or screws (not provided).
- 3 After installation is complete, connect power. You may use 85LM plug-in or 95LM wired-in transformer, or power provided from your operator (9-30 V AC, 9-34 Vdc or see power ratings on next page).

**NOTE** The receiver can command the operator to close the door or gate by constant pressure. This feature is only available with a wireless control panel (Model 885LM). To enable this feature, press and hold the push bar until the gate or garage door moves to the closed position.

### ⚡ ⚠ WARNING

To prevent possible SERIOUS INJURY or DEATH from electrocution:

- Be sure power is NOT connected BEFORE installing the receiver.

To prevent possible SERIOUS INJURY or DEATH from a moving gate or garage door:

- ALWAYS keep remote controls out of reach of children. NEVER permit children to operate, or play with remote control transmitters.
- Activate gate or door ONLY when it can be seen clearly, is properly adjusted, and there are no obstructions to door travel.
- ALWAYS keep gate or garage door in sight until completely closed. NEVER permit anyone to cross path of moving gate or door.

### ⚠ WARNING

To prevent possible SERIOUS INJURY or DEATH, the use of CONSTANT OPERATION on residential openers is PROHIBITED. When a receiver is used to activate a commercial door opener, a reversing edge MUST be installed on the bottom of the door. Failure to install a reversing edge under these circumstances may result in SERIOUS INJURY or DEATH to persons trapped beneath the door.

### WIRING

Refer to your commercial door operator or gate operator owner manual or wiring diagrams for specific wiring information.

#### SINGLE CHANNEL

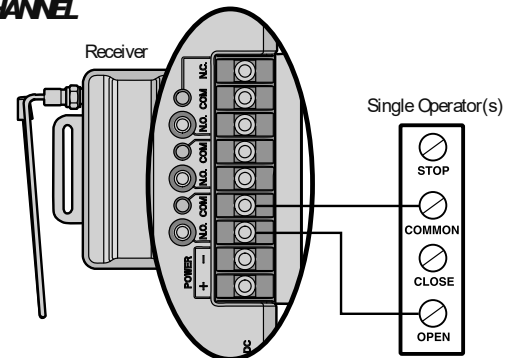

#### THREE CHANNEL

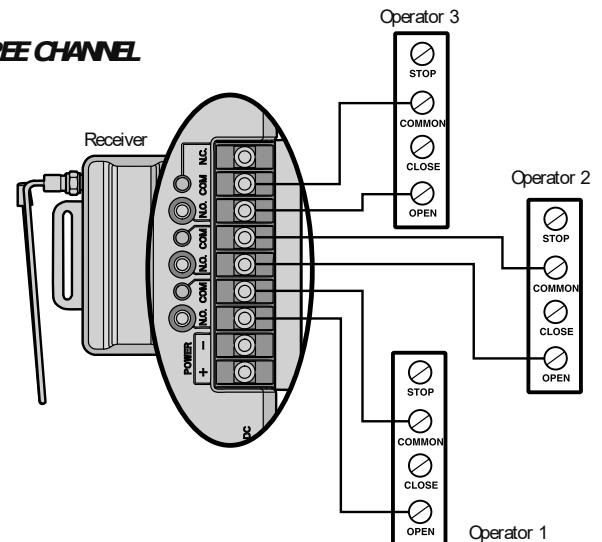

## WIRING CONTINUED

### OPEN, CLOSE, STOP

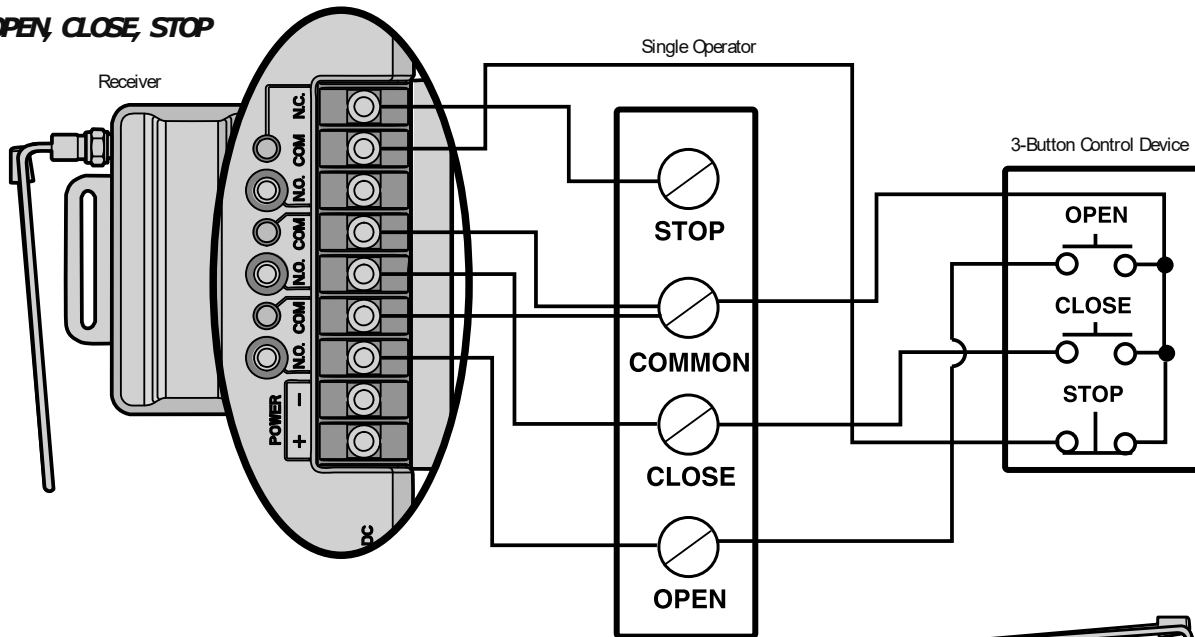

Refer to your commercial door operator or gate operator wiring diagrams for instructions on connecting two or more 3-Button control devices.

## PROGRAMMING

### PROGRAM A SINGLE BUTTON REMOTE CONTROL

- 1 Press and release the Learn button for the selected channel on the receiver. The corresponding LED will glow steadily for 30 seconds.
- 2 Within 30 seconds press and hold the button on the remote control that you wish to program to the receiver.
- 3 Release the remote control button when the LED on the receiver blinks, then turns off. Programming is complete.

Repeat the steps above for each remote control you would like to program.

### PROGRAM A 3-BUTTON REMOTE CONTROL AS OPEN, CLOSE, AND STOP

- 1 Press and release the CH1 Learn button on the receiver.
- 2 Within 30 seconds press the desired OPEN button on the remote control.
- 3 Press and release the CH2 Learn button on the receiver.
- 4 Within 30 seconds press the desired CLOSE button on the remote control.
- 5 Press and release the CH3 Learn button on the receiver.
- 6 Within 30 seconds press the desired STOP button on the remote control.

**NOTE:** If a remote control button is not pressed within 30 seconds, the LED next to the selected Learn button will turn OFF. In that case, repeat the programming.

### TO ERASE THE MEMORY

- 1 Press and hold the Learn button for the channel you want to erase. Release the button when the corresponding LED turns off; the memory has been erased.

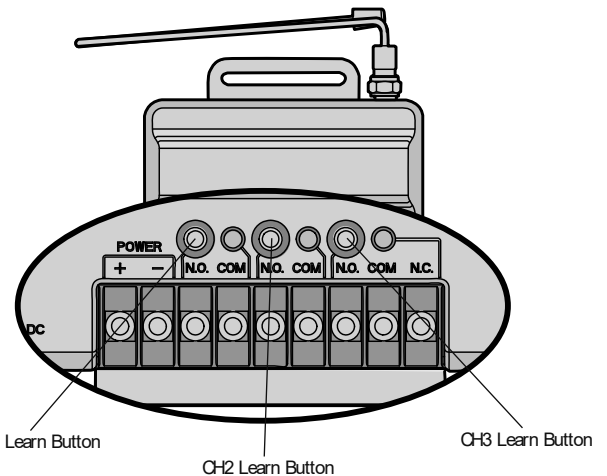

SPECIFICATIONS	
Contact Rating	5 Amps 28 Vac or dc Max.
Power	9-30V AC or 9-34V DC, 50mA, 60Hz
RF Frequency	.310, 315, and 390 MHz
<b>NOTE:</b> If your operator does not meet the power specifications you will need a transformer (Model 85LM plug-in or 95LM wired-in).	
COMPATIBLE ACCESSORIES	
Remote Controls	Models 811LM, 813LM, 891LM, 893LM, 890MAX, 893MAX, 895MAX, 892LT, 894LT
Keypads	Models 877LM, 877MAX
Antenna Extension Kits	Models 86LM, 86LMT
Antenna Only	K77-36541

NOTICE: To comply with FCC and/or Industry Canada (IC) rules, adjustment or modifications of this receiver are prohibited. THERE ARE NO USER SERVICEABLE PARTS. This device complies with Part 15 of the FCC rules and IC RSS-210. Operation is subject to the following two conditions: (1) this device may not cause harmful interference, and (2) this device must accept any interference received, including interference that may cause undesired operation.

**FOR TECHNICAL SUPPORT DIAL OUR TOLL FREE NUMBER:**

**1-800-528-2806**

## UTILISATION

Cet appareil peut s'utiliser comme récepteur à un ou trois canaux de manière à commander jusqu'à trois ouvre-porte ou ouvre-portail commerciaux. Il peut aussi s'utiliser avec une télécommande à 3 boutons pour actionner les fonctions OUVERTURE, FERMETURE et ARRÊT d'un ouvre-porte commercial. Il n'est pas conçu pour fonctionner avec les ouvre-porte et autres appareils compatibles MyQ™.

Chaque canal est compatible avec un certain nombre de télécommandes et de claviers comme indiqué ci-dessous :

- Canal 1 : 50 télécommandes et 2 claviers
- Canal 2 : 20 télécommandes et 2 claviers
- Canal 3 : 20 télécommandes et 2 claviers

Lorsque le canal a atteint la pleine capacité des télécommandes, tous les témoins DEL clignotent trois fois. Lorsque le canal a atteint la pleine capacité des claviers, tous les témoins DEL clignotent quatre fois. On peut programmer des accessoires supplémentaires; toutefois, l'accessoire nouvellement programmé remplacera celui qui a été programmé en premier.

**REMARQUE :** Le récepteur ne vous permet de programmer un bouton de télécommande que pour un seul canal à la fois. Par exemple, si le bouton de la télécommande est déjà programmé pour le canal 1, puis pour le canal 3, il sera effacé du canal 1 et ne fonctionnera que sur le canal 3.

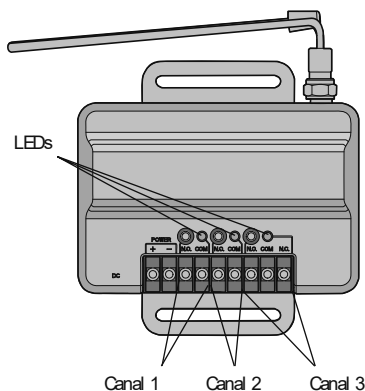

## INSTALLATION

Le récepteur et l'antenne utilisent des connecteurs coaxiaux de type F. L'antenne peut être connectée directement au récepteur ou installée à distance avec une rallonge coaxiale modèle 86LM (4,57 m) ou 86LMT (7,62 m).

- 1 Choisir pour installer le récepteur un emplacement permettant d'accéder aux bornes et laissant assez d'espace pour l'antenne. S'assurer que l'antenne ne touche pas de surfaces métalliques. NE PAS plier ou courber l'antenne.
- 2 Fixer solidement le récepteur avec les bandes auto-agrippantes (fournies) ou avec des vis (non fournies).
- 3 Une fois l'installation terminée, branchez le cordon d'alimentation. Vous pouvez utiliser un transformateur 85LM à prise ou 95LM à câble, ou alimenté par votre opérateur (9-30 V c.a., 9-34 V c.c. ou consultez les régimes d'alimentation à la page suivante).

**REMARQUE :** Le récepteur peut commander à l'opérateur de fermer la porte ou le portail par une pression constante. Cette fonction est uniquement disponible avec un panneau de commande sans fil (modèle 885LM). Pour activer cette fonction, appuyez sur la barre de poussée et gardez-la enfoncée jusqu'à ce que le portail ou la porte de garage se déplace vers la position fermée.



## AVERTISSEMENT

Pour prévenir le risque de BLESSURES GRAVES ou de DÉCÈS par électrocution :

- S'assurer que l'alimentation n'est PAS branchée AVANT d'installer le récepteur.

Pour prévenir le risque de BLESSURES GRAVES ou de DÉCÈS causés par un portail ou une porte de garage en mouvement :

- TOUJOURS tenir les télécommandes hors de portée des enfants. Ne JAMAIS laisser un enfant utiliser une télécommande ou jouer avec.
- Actionner la porte ou le portail UNIQUEMENT lorsqu'ils sont bien visibles et bien ajustés et que rien ne fait obstacle à leur mouvement.
- TOUJOURS surveiller du regard le portail ou la porte de garage jusqu'à sa fermeture complète. Ne JAMAIS laisser personne franchir une porte ou un portail en mouvement.



## AVERTISSEMENT

Pour prévenir le risque de BLESSURES GRAVES ou de DÉCÈS, il est INTERDIT d'utiliser les ouvre-porte résidentiels EN FONCTIONNEMENT CONTINUËL.

Avant d'utiliser un récepteur pour actionner un ouvre-porte commercial, il est IMPÉRATIF d'installer une tranche de sécurité (barre palpeuse) au bas de la porte. L'absence de tranche de sécurité convenablement installée peut entraîner des BLESSURES GRAVES ou un DÉCÈS si quelqu'un se retrouve coincé sous la porte.

## CÂBLAGE

Pour obtenir des informations précises sur le câblage, consulter la notice ou les schémas de câblage de l'ouvre-porte ou ouvre-portail.

### UN CANAL

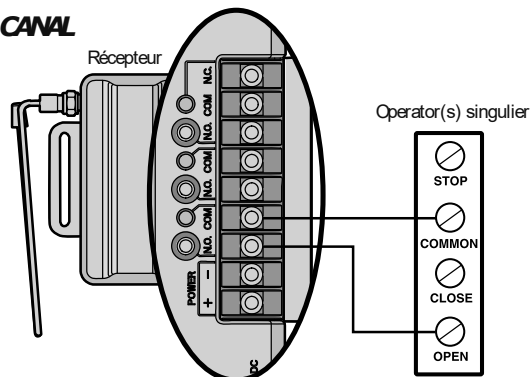

### TROIS CANAL

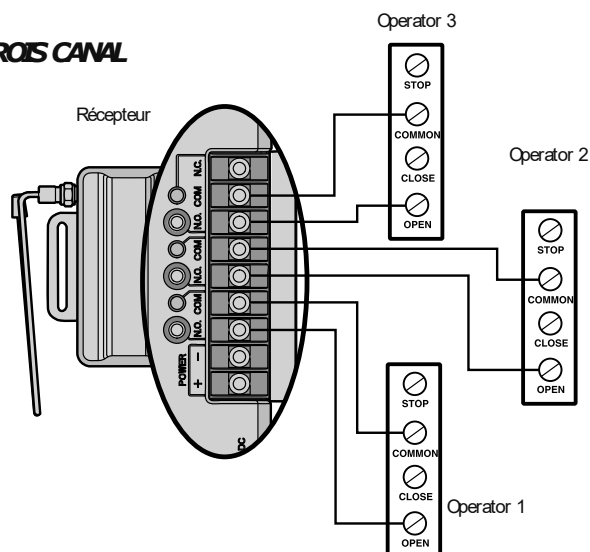

## CÂBLAGE (SUITE)

OUVERTURE, FERMETURE,  
ARRÊT

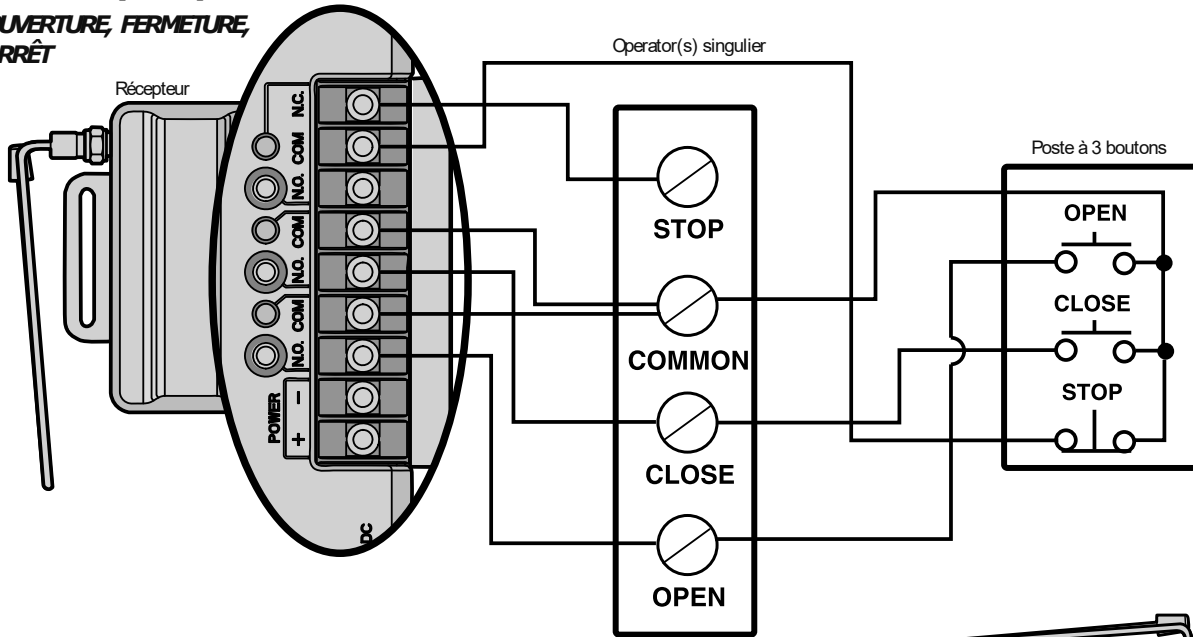

Consulter les schémas de câblage de l'ouvre-porte ou de l'ouvre-portail pour obtenir des instructions sur la connexion de deux ou plusieurs télécommandes à 3 boutons.

## PROGRAMMATION

### PROGRAMACIÓN DE UN CONTROL REMOTO DE 1 BOTÓN

- 1 Presser et relâcher le bouton de programmation du canal sélectionné sur le récepteur. Le témoin correspondant s'allume et reste allumé pendant 30 secondes.
- 2 Dans les 30 secondes, presser et maintenir enfoncé le bouton de la télécommande à programmer pour ce récepteur.
- 3 Le témoin du récepteur se met à clignoter, puis s'éteint. Relâcher alors le bouton de la télécommande. La programmation est terminée.

Répéter les étapes ci-dessus pour chaque télécommande à programmer.

### PROGRAMMATION DES FONCTIONS OUVERTURE, FERMETURE ET ARRÊT D'UNE TÉLÉCOMMANDE À 3 BOUTONS

- 1 Presser et relâcher le bouton de programmation du canal 1 sur le récepteur.
- 2 Dans les 30 secondes, appuyer sur le bouton d'ouverture souhaité sur la télécommande.
- 3 Presser et relâcher le bouton de programmation du canal 2 sur le récepteur.
- 4 Dans les 30 secondes, appuyer sur le bouton de fermeture souhaité sur la télécommande.
- 5 Presser et relâcher le bouton de programmation du canal 3 du récepteur.
- 6 Dans les 30 secondes, appuyer sur le bouton d'arrêt souhaité sur la télécommande.

**REMARQUE :** Si aucun bouton de la télécommande n'est enfoncé dans les 30 secondes, le témoin du bouton de programmation sélectionné s'éteint. Dans ce cas, recommencer la programmation.

### POUR EFFACER LA MÉMOIRE

- 1 Presser et maintenir enfoncé le bouton de programmation du canal à effacer. Relâcher le bouton lorsque le témoin correspondant s'éteint. La mémoire est alors effacée.

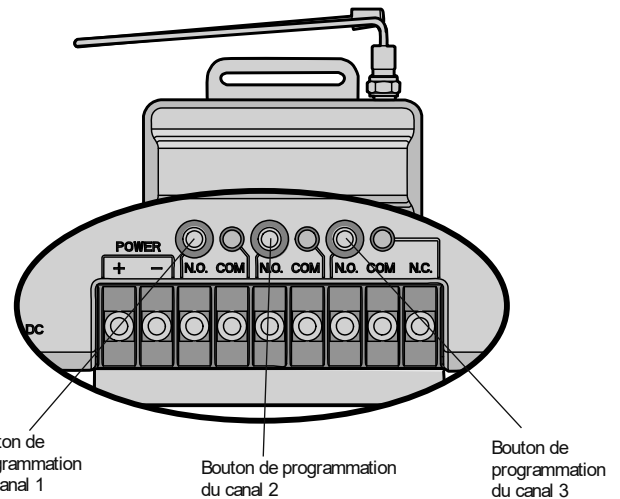

### CARACTÉRISTIQUES TECHNIQUES

Régime de contact . . . . . 5 A, 28 V (c.a. ou c.c.) max.  
Alimentation . . . . . 9 à 30 V c.a. ou 9 à 34 V c.c., 50 mA, 60 Hz  
Fréquences radio . . . . . 310, 315 et 390 MHz

**REMARQUE :** Si l'ouvre-porte ou l'ouvre-portail ne répond pas à ces spécifications électriques, il est nécessaire d'utiliser un transformateur modèle 85LM (à fiche de branchement) ou 95LM (à câblage direct).

### ACCESSOIRES COMPATIBLES

Télécommandes . . Modèles 811LM, 813LM, 891LM, 893LM, 890MAX, 893MAX, 895MAX, 892LT, 894LT  
Claviers . . . . . Modèles 877LM, 877MAX  
Rallonges d'antenne . . . . . Modèles 86LM, 86LMT  
Antenne seule . . . . . K77-36541

AVIS : Conformément aux règlements de la FCC et d'Industrie Canada, il est interdit de modifier ce récepteur ou ses réglages d'origine. CET APPAREIL NE COMPORTE AUCUNE PIÈCE POUVANT ÊTRE RÉPARÉE PAR L'UTILISATEUR.

Cet appareil est conforme à la partie 15 des règlements de la FCC et à la norme RSS-210 d'Industrie Canada. Son utilisation est subordonnée aux deux conditions suivantes : (1) l'appareil ne doit pas causer d'interférences nuisibles et (2) l'appareil doit accepter toute interférence reçue, y compris celles qui pourraient un fonctionnement indésirable.

**POUR L'ASSISTANCE TECHNIQUE, APPELER LE NUMÉRO SANS FRAIS SUIVANT :**

**1-800-528-2806**

© 2011, The Chamberlain Group, Inc.  
All Rights Reserved  
Tous droits réservés

### Introduction

This product is for use with models 850LM and 860LM universal receivers as well as any Security+ 2.0™ compatible LiftMaster gate operators. Depending on the receiver channel, you may program up to 20 or 50 remote control dip switch configurations to your receiver. To exceed the 20/50 limit, match the dip switches in the new remote control to the dip switches in an existing remote control.



811LM



813LM

### WARNING

To prevent possible **SERIOUS INJURY** or **DEATH** from a moving gate or garage door:

- ALWAYS keep remote controls out of reach of children. NEVER permit children to operate, or play with remote control transmitters.
- Activate gate or door ONLY when it can be seen clearly, is properly adjusted, and there are no obstructions to door travel.
- ALWAYS keep gate or garage door in sight until completely closed. NEVER permit anyone to cross path of moving gate or door.

### Set the Dip Switches

- 1 Slide the cover open to access the dip switches in the remote control.
- 2 Use a pen or screwdriver to slide the dip switches to any position you want (ON or OFF).

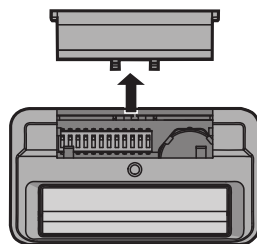

### Programming

- 1 Press and release the Learn button for the selected channel on the receiver. The corresponding LED will glow steadily for 30 seconds.
- 2 Within 30 seconds press and hold the button on the remote control that you wish to program to the receiver.
- 3 Release the remote control button when the LED on the receiver blinks, then turns off. Programming is complete.

Repeat the steps above for each remote control you would like to program.

If you would like to program an 813LM as an OPEN, CLOSE, STOP, refer to the 850LM receiver manual.

For programming to the 860LM receiver or to a Security+ 2.0™ compatible gate operator, please refer to the receiver/operator instructions manual for location of the learn button(s).

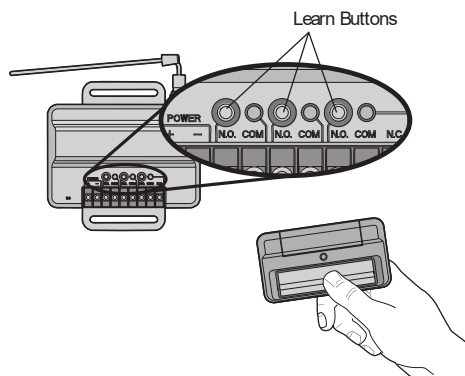

## The Remote Control Battery

---

The 3 volt battery should produce power for 1 year. Dispose of old batteries properly.

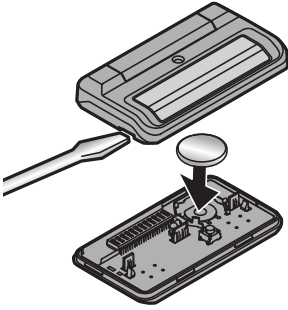

### **WARNING**

To prevent possible **SERIOUS INJURY** or **DEATH**:

- NEVER allow small children near batteries.
- If battery is swallowed, immediately notify doctor.

NOTICE: To comply with FCC and/or Industry Canada (IC) rules, adjustment or modifications of this transceiver are prohibited. THERE ARE NO USER SERVICEABLE PARTS.

This device complies with Part 15 of the FCC rules and IC RSS-210. Operation is subject to the following two conditions: (1) this device may not cause harmful interference, and (2) this device must accept any interference received, including interference that may cause undesired operation.

## Replacement Parts

---

Visor Clip .....	29C137
3V Battery .....	10A20

**FOR TECHNICAL SUPPORT DIAL OUR TOLL FREE NUMBER:**

**1-800-528-9131**

[www.liftmaster.com](http://www.liftmaster.com)

### Introduction

Cet article est utilisé avec les récepteurs universels modèles 850LM et 860LM, ainsi qu'avec toute commande de barrière LiftMaster compatible au Security+ 2.0™. Selon le canal de réception, vous pouvez programmer de 20 à 50 configurations de commutateurs DIP de télécommande sur votre récepteur. Pour dépasser la limite 20/50, appariez les commutateurs DIP de la nouvelle télécommande aux commutateurs DIP de la télécommande existante.



811LM



813LM



### AVERTISSEMENT

Afin d'éliminer les risques de BLESSURES GRAVES ou de MORT découlant de l'actionnement d'une clôture ou d'une porte de garage :

- TOUJOURS garder les télécommandes hors de la portée des enfants. NE JAMAIS laisser un enfant manipuler une télécommande ni jouer avec elle.
- Actionner la clôture ou la porte UNIQUEMENT lorsqu'elle est clairement visible, correctement ajustée et que le mécanisme est libre de toute entrave.
- TOUJOURS garder la clôture ou la porte de garage en vue jusqu'à sa fermeture complète. NE permettez à quiconque de passer lorsqu'une clôture ou une porte est en mouvement.

### Réglage des commutateurs DIP

- 1 Ouvrez le couvercle en le faisant glisser pour avoir accès aux commutateurs DIP de la télécommande.
- 2 À l'aide d'une plume ou d'un tournevis, glissez les commutateurs DIP à la position souhaitée (ON ou OFF).

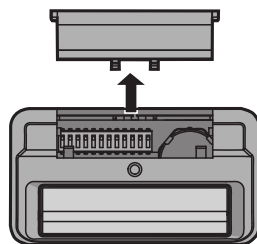

### Programmation

- 1 Pressez puis relâchez le bouton Learn du canal sélectionné sur le récepteur. Le voyant DEL correspondant reste allumé pendant 30 secondes.
- 2 Dans les 30 secondes, pressez et maintenez le bouton de la télécommande que vous voulez programmer sur le récepteur.
- 3 Relâchez le bouton de la télécommande lorsque le voyant DEL du récepteur clignote, puis s'éteint. La programmation est terminée.

Reprenez les étapes précédentes avec chaque télécommande que vous souhaitez programmer.

Reportez-vous au manuel du récepteur 850LM si vous souhaitez programmer les fonctions OPEN, CLOSE, STOP (ouverture, fermeture, arrêt) sur un 813LM.

Pour programmer sur le récepteur 860LM ou un dispositif de commande compatible à un Security+ 2.0™, reportez-vous au manuel d'instructions récepteur/dispositif de commande pour l'emplacement du/des bouton(s) Learn.

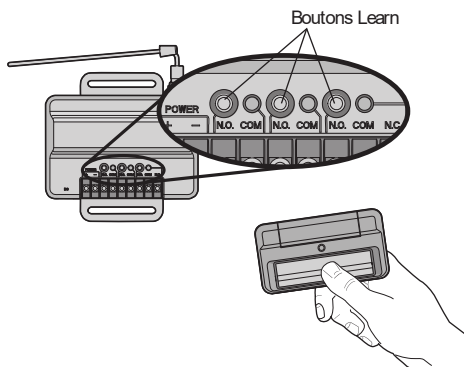



## La pile de télécommande

La pile de 3 V devrait produire suffisamment de puissance pour au moins un an. Se débarrasser des vieilles piles convenablement.

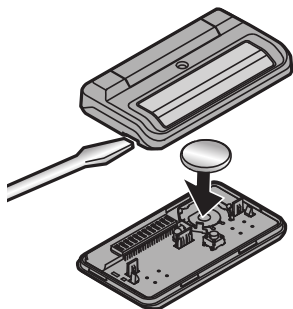

## AVERTISSEMENT

Pour prévenir d'éventuelles BLESSURES GRAVES ou la MORT :

- Ne JAMAIS laisser de petits enfants à proximité des piles.
- Aviser immédiatement un médecin en cas d'ingestion de la pile.

AVIS : Les règles de la FCC et/ou d'Industrie Canada (IC) interdisent tout ajustement ou toute modification de ce récepteur. IL N'EXISTE AUCUNE PIÈCE SUSCEPTIBLE D'ÊTRE ENTRETENUE PAR L'UTILISATEUR.

Cet appareil est conforme aux dispositions de la partie 15 du règlement de la FCC et de la norme IC RSS-210. Son utilisation est assujettie aux deux conditions suivantes : (1) ce dispositif ne peut causer des interférences nuisibles, et (2) ce dispositif doit accepter toute interférence reçue, y compris une interférence pouvant causer un fonctionnement non souhaité.

## Pièces de rechange

Pince du pare-soleil .....	29C137
Pile de 3V .....	10A20

**POUR OBTENIR DE L'ASSISTANCE TECHNIQUE, COMPOSER NOTRE NUMÉRO GRATUIT :**

**1-800-528-9131**

**[www.liftmaster.com](http://www.liftmaster.com)**

DUAL HEIGHT PEDESTAL

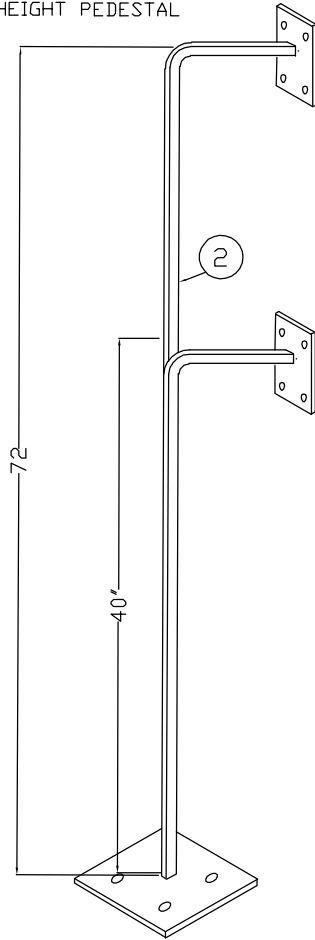

SINGLE HEIGHT PEDESTAL

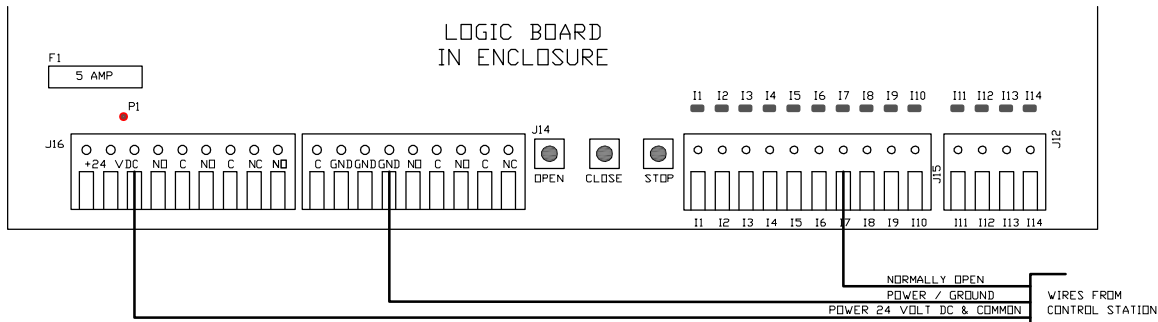
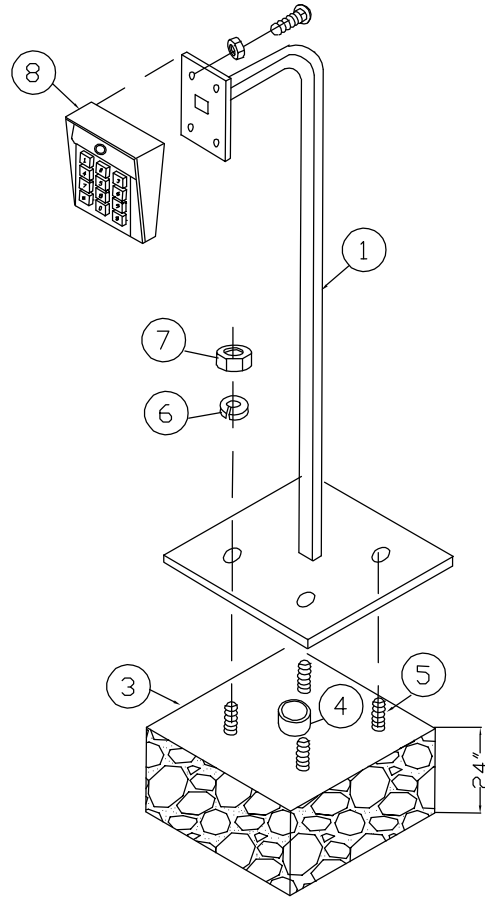

NOTE: INPUT TO TERMINAL 17 FROM THE CONTROL STATION MUST BE 24 VOLT DC POSITIVE

TILT-A-WAY HYJG 1  
REMOTE CONTROL STATION PEDESTAL AND GATELOCK

REF NO.	PART NO.	DESCRIPTION	REQ NO
1	N/A	Single Height Pedestal	1
2	N/A	Dual Height Pedestal 72" in Height	1
3	N/A	Concrete Support Pier 15" X 15" X 24" Deep	1
4	N/A	1" in Diameter Electrical Conduit with 2 1/2" projection above Concrete. Conduit Routed from Barrier Pedestal.	1
5	N/A	1/2" x 8" Expansion Bolt	4
6	NA	1/2" Lock Washer	4
7	N/A	1/2" Hex Nut	4
8	N/A	Remote Control Station of Choice (Included are bolts, nuts, keys and plate.	4

# TILT-A-WAY HYJG 1 MONITORED REVERSING EDGE INSTALLATION

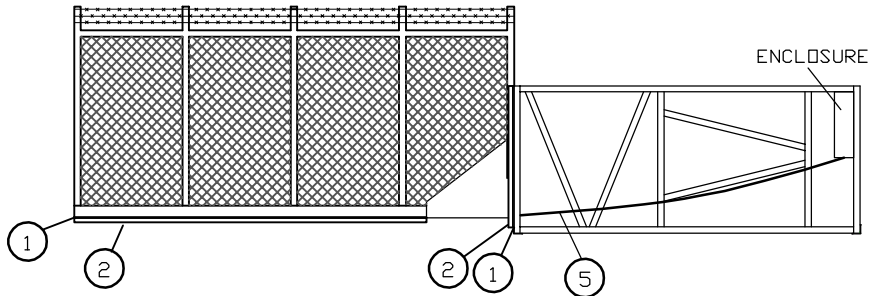

NOTE: FOR THE MONITORED EDGE TO FUNCTION PROPERLY IT MUST BE ENABLED. THIS FUNCTION IS IN THE TIMING AND OPTIONS MENU. SAFETY RESPONSES SUB MENU. MONITORED OBSTRUCTION EDGE (DISABLED / ENABLED)

TWO 9.09K OHMS RESISTORS ON EACH CIRCUIT

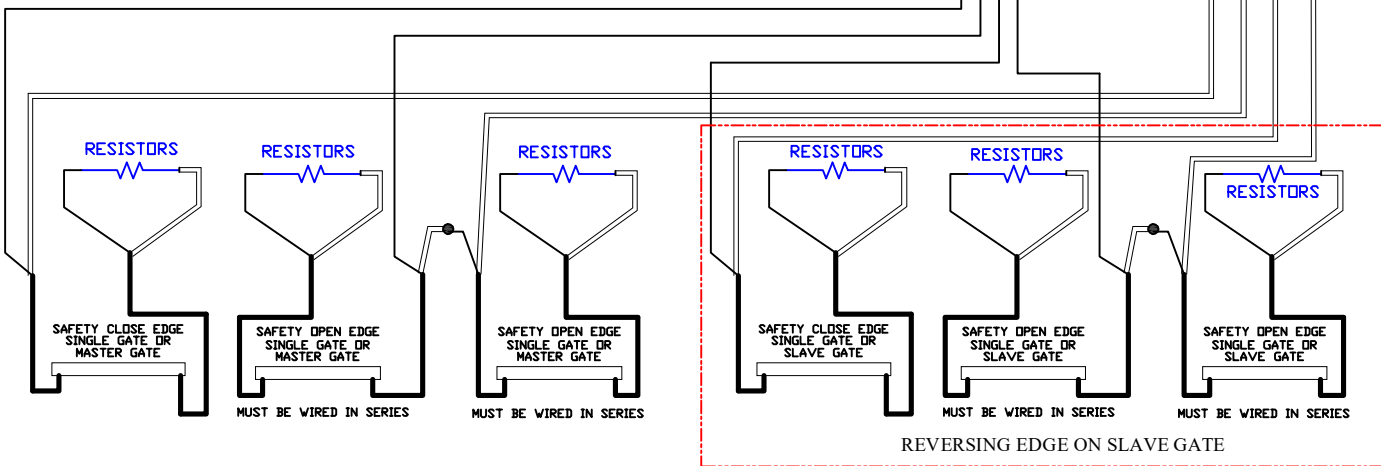
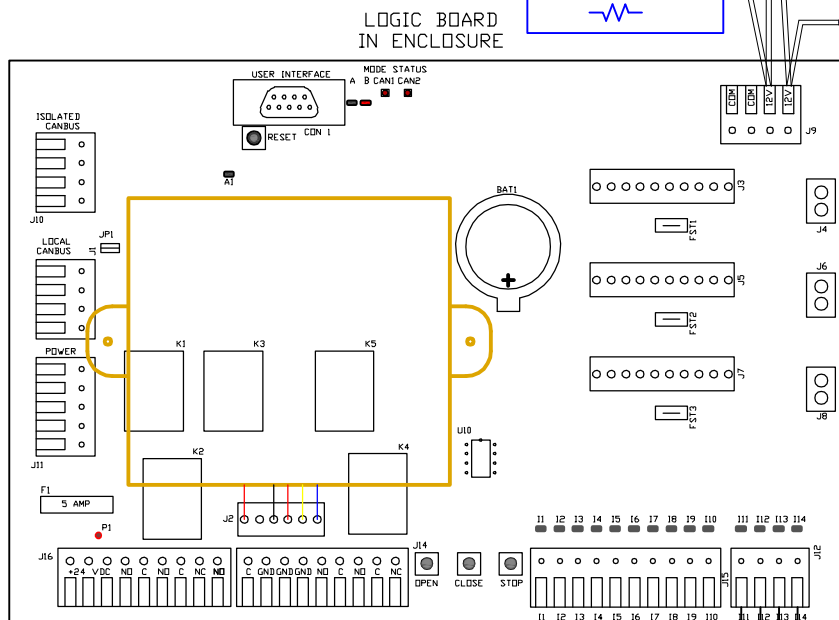

REF NO.	PART NO.	DESCRIPTION	REQ NO
1	PEO653	Opening Edge Holding Track	2
2	PEO651-A	Open safety, with resistor	2
3	PEO652-A Length	Close safety, with resistor	1
4	PEO654	Closing Edge Holding Track (Length is required)	1
5	PEO410	Junction Box	1
6	N/A	18/5 S O Cord	AS REQ
	PEO246	1/2" Strain Relief Fitting (not shown)	4
	PEO237	Junction Box Cover (not shown)	1

# TILT-A-WAY HYJG 1 REVERSING EDGE INSTALLATION

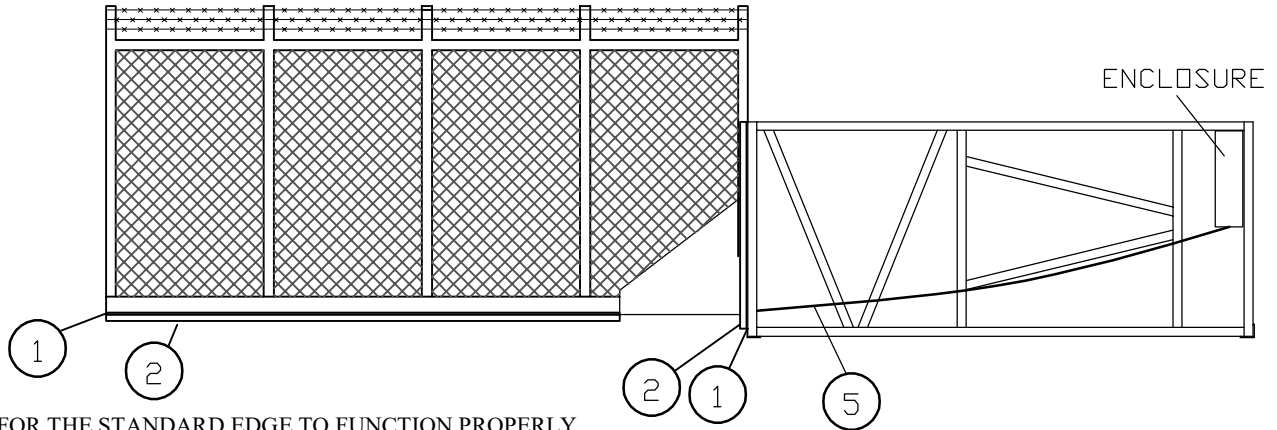

NOTE: FOR THE STANDARD EDGE TO FUNCTION PROPERLY THE MONITORED OBSTRUCTION EDGE MUST BE DISABLED. THIS FUNCTION IS IN THE TIMING AND OPTIONS MENU. SAFETY RESPONSES SUB MENU.  
MONITORED OBSTRUCTION EDGE (DISABLED / ENABLED)

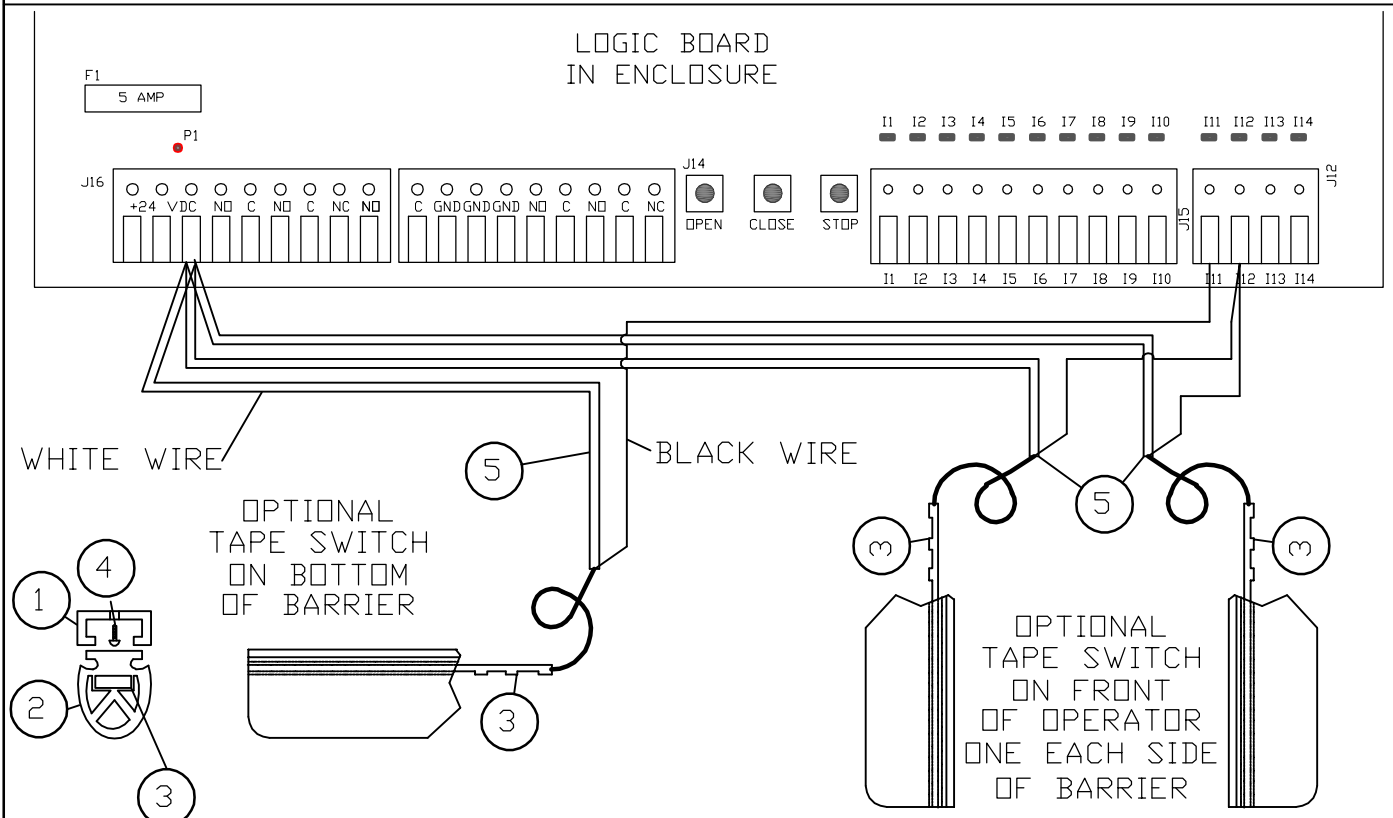

CONNECT CLOSING TAPE SWITCH BLACK WIRE TO TERMINAL 111  
CONNECT OPENING TAPE SWITCH BLACK WIRE TO TERMINAL 112

REF NO.	PART NO.	DESCRIPTION	REQ NO
1	PEO243	Reversing Edge Holding Track (Length is required)	1
2	PEO243A	Reversing Edge Rubber Strip (Length is required) (Insert in track from front)	1
3	PEO244-Length	C Switch (Order length as required) (Insert in track from front)	1
4	N/A	8 X 3/4" Tapping Phillips Pan Head Screw	as req.
5	N/A	Cord From C Switch	

# Tilt- A-Way HYJG 1 Control Board Program Menu

8/15/2018

To Enter Main Menu press and hold button SW2 for about 4 seconds.  
To view menus press and release button SW4 to scroll up, and SW3 to scroll down.

To enter menu, or submenu press and release button SW1.

To save changes to submenus press and release button SW1.

To exit submenus, or main menu press and release button SW2.

- REALTIME STATUS. This menu is helpful for trouble shooting problems with the gate system.
  - Input Status. In this submenu you can view which inputs are active, or inactive.
    - Input state open button *“Input clear / Input asserted”*
    - Input state close button *“Input clear / Input asserted”*
    - Input state stop button *“Input clear / Input asserted”*
    - Input state single button *“Input clear / Input asserted”*
    - Input state reverse open, terminal *“Input clear / Input asserted”*
    - Input state timer set *“Input clear / input asserted”*
    - Input state timer hold *“Input clear / Input asserted”*
    - Input state aux timer *“Input clear / Input asserted”*
    - Input state UL reset (on board) *“Input clear / Input asserted”*
    - Input state remote (N.O. contact) *“Contact open / Contact closed”*
    - Input state remote (N.C. contact) *“Contact open / Contact closed”*
    - Input state loop slot #J3 *“Input clear / Input asserted”*
    - Input state loop slot #J5 *“Input clear / Input asserted”*
    - Input state loop slot #J7 *“Input clear / Input asserted”*
    - Input state auxiliary #1 *“Input clear / Input asserted”*
    - Input state auxiliary #2 *“Input clear / Input asserted”*
    - Input state leaf #1 close obstruct edge *“Input clear / Input asserted”*
    - Input state leaf #1 open obstruct edge *“Input clear / Input asserted”*
    - Input state leaf #1 close limit *“Input clear / Input asserted”*
    - Input state leaf #1 open limit *“Input clear / Input asserted”*
    - Input state leaf #2 close obstruct edge *“Input clear / Input asserted”*
    - Input state leaf #2 open obstruct edge *“Input clear / Input asserted”*
    - Input state leaf #2 close limit *“Input clear / Input asserted”*
    - Input state leaf #2 open limit *“Input clear / Input asserted”*

- Output Status. In this submenu you can view witch output relays are latched, or unlatched.
  - Output state entrapment (K1) *“relay not energized / relay energized”*
  - Output state prewarn (K2) *“relay not energized / relay energized”*
  - Output state auxiliary #1 (K3) *“relay not energized / relay energized”*
  - Output state auxiliary #2 (K4) *“relay not energized / relay energized”*
  - Output state auxiliary #3 (K5) *“relay not energized / relay energized”*
- Motor Current. (for model DCM only) This submenu is used only for to view amp draw of the motor so the proper value can be inserted in the safety threshold submenu.
  - Leaf # 1 maximum deviation threshold, last cycle (gate stopped)
  - X.X A (gate stopped)
  - Motor Current Leaf #1 (gate moving)
  - Approx Motor Current (gate moving)
  - X.X A (this value changes as the gate moves thru a cycle. Watch for the highest value during the cycle to enter a proper setting in the safety threshold submenu leaf #1)
  - Leaf # 2 maximum deviation threshold, last cycle (gate stopped)
  - X.X A (gate stopped)
  - Motor Current Leaf #1 (gate moving)
  - Approx Motor Current (gate moving)
  - X.X A (this value changes as the gate moves thru a cycle. Watch for the highest value during the cycle to enter a proper setting in the safety threshold submenu leaf #2)
- Battery Voltage. (for model DCM only) This submenu shows voltage being supplied to the logic board. Any voltage over 24 vdc will show as 24 volts.
  - Leaf #1 / 24.0 volts
  - Leaf # 2 / 24.0 volts
- TIMING AND OPTIONS. In this menu you can adjust user settings.
  - Basic settings
    - Current clock time (factory set to mountain time) *“12:01 am”*
    - Current calendar date *“1/1/2013”*
    - Auto-Close delay (factory set at 10 seconds) *“OFF / 15:00”*
    - Close command over rides auto-close (factory set Enabled) *“Disabled / Enabled”*
    - Single input sets the auto-close timer (factory set Enabled) *“Disabled / Enabled”*
    - Single input direction reverse (factory set Enabled) *“Disabled / Enabled”*

- Pause delay before direction reversal (factory set Enabled) *“Disabled / Enabled”*
- Safety Responses
  - Maximum motor run (0:30 seconds factory set) *“0:05 to 1:30”*
  - Motion reversal on safety (factory set Enabled) *“Disabled / Enabled”*
  - Safety sets the auto-close timer (factory set Enabled) *“Disabled / Enabled”*
  - Inherent safety (for model DCM only factory set Disabled) *“Disabled / Enabled”*
  - Safety threshold Leaf # 1 closing (for model DCM only value set at factory, Inherent safety must be checked monthly) *“0.0 A to 20.0 A”*
  - Safety threshold Leaf # 1 opening (for model DCM only value set at factory, Inherent safety must be checked monthly) *“0.0 A to 20.0 A”*
  - Safety threshold Leaf #2 closing (for model DCM only value set at factory, Inherent safety must be checked monthly) *“0.0 A to 20.0 A”*
  - Safety threshold Leaf #2 opening (for model DCM only value set at factory, Inherent safety must be checked monthly) *“0.0 A to 20.0 A”*
  - Motor inrush ignore period (factory set 1.0 seconds) *“0.0 seconds to 2.0 seconds”*
  - Position Feedback Obstruction Detect (for hydraulic gate only) (factory set Enabled) *“Disabled / Enabled”*
  - Monitored Obstruction Edge *“Disabled / Enabled”*
- Speed Settings (for model DCM only)
  - Gate position for ramp up completion (factory set 5%) *“XX%”*
  - Gate position for ramp down start (factory set 80%) *“XX%”*
  - Slow stop ramp-down on gate reversal (factory set 0.5 seconds) *“0.0 seconds to 3.0 seconds”*
  - Motor ramp starting speed (factory set 60%) *“XX%”*
  - Maximum motor speed (factory set 100%) *“XX%”*
  - Motor ramp end speed (factory set 40%) *“XX%”*
- Lockout Schedule. When lockout schedule is set the gate will not open until lockout schedule ends except for a free exit loop will open the gate, or an input to terminal timer set input I7.
  - Entry lockout enable Schedule # 1 *“Disabled / Enabled”*
  - Entry lockout start Schedule # 1 *“set for time to start lockout am or pm and day of week”*
  - Entry lockout end Schedule # 1 *“set for time to end lockout am or pm and day of week”*
  - Repeat for all days that Lockout is needed.

- Auto-Open schedule. When auto-open schedule is set no function will close gate until auto-open schedule ends.
  - Auto-Open gate enable Schedule # 1 “*Disabled / Enabled*”
  - Auto-Open gate start time Schedule # 1 “*set for time to start auto-open am or pm and day of week*”
  - Auto-Open gate end time Schedule # 1 “*set for time to end auto-open am or pm and day of week*”
  - Repeat for all days that Auto-Open is needed.
  
- Battery (for model DCM only)
  - Fail-Safe / Fail-secure Selection “*fail safe / fail secure*”
  - Battery dropout voltage (factory set 18.0 volts) “*17.0 to 23.0*”
  - Battery recovery voltage (factory set 20.0 volts) “*18.0 to 23.0*”
  
- Auxiliary I / O
  - Auxiliary #1 input function assignment “*not used / open / close / stop / single / timer hold / reverse open loop / opening safety edge / closing safety edge / UL entrapment reset*”
  - Auxiliary #2 input function assignment “*not used / open / close / stop / single / timer hold / reverse open loop / opening safety edge / closing safety edge / UL entrapment reset*”
  - Auxiliary output #1 function “*output disabled / secondary entrapment alarm / hold aux relay when maintenance due / hold aux relay on auto-close delay / unlock pulse / pulse aux relay on close limit switch / pulse aux relay on open limit switch / pulse aux relay on open motion / pulse aux relay on close motion / hold aux relay on close limit switch / hold aux relay on open limit switch / hold aux relay on opening motion / hold aux relay on closing motion / pulse aux relay on motion prewarn / pulse aux relay on opening prewarn only / pulse aux relay on closing prewarn only / pulse aux relay on auxiliary input #1 / hold aux relay on auxiliary input #1 / pulse aux relay on auxiliary input #2 / hold aux relay on auxiliary input #2 / hold aux relay on any motion / hold aux relay on arming loop assertion*”
  - Auxiliary output #1 pulse duration “*0.1 seconds to 5.0 seconds*”
  - Auxiliary output #2 function “*output disabled / secondary entrapment alarm / hold aux relay when maintenance due / hold aux relay on auto-close delay / unlock pulse / pulse aux relay on close limit switch / pulse aux relay on open limit switch / pulse aux relay on open motion / pulse aux relay on close motion / hold aux relay on close limit switch / hold aux relay on open limit switch / hold aux relay on opening motion / hold aux relay on closing motion / pulse aux relay on motion prewarn / pulse aux relay on opening prewarn only / pulse aux relay on closing prewarn only / pulse aux relay on auxiliary input #1 / hold aux relay on auxiliary input #1 / pulse aux relay on auxiliary input #2 / hold aux relay on*





- If service reminder on or after date is Enabled then the date can be set here “08/21/2021”
  - Test relays
    - Relay Test / Latch “no latched relays / latch relay K1 / latch relay K2 / latch relay K3 / latch relay K4 / latch relay K5”
  - Factory config. This submenu is for factory use only.
    - Caution! Apply volts and trim calibration “24.0 volts”
    - Caution! Zero life time cycle counter “no / yes”
    - Caution! Reset all settings to defaults “no / yes”
- Statistics
  - Gate Cycle Count
    - Total gate life time cycle count (000000)
    - Cycle count since last service reset (00000)
  - Motor board #1 bus. This submenu is factory use only.
  - Motor board #2 bus. This submenu is factory use only.
- Event Logs
  - General Event Log
    - Event #1 (most recent)
  - Safety Event Log
    - Event #1 (most recent)

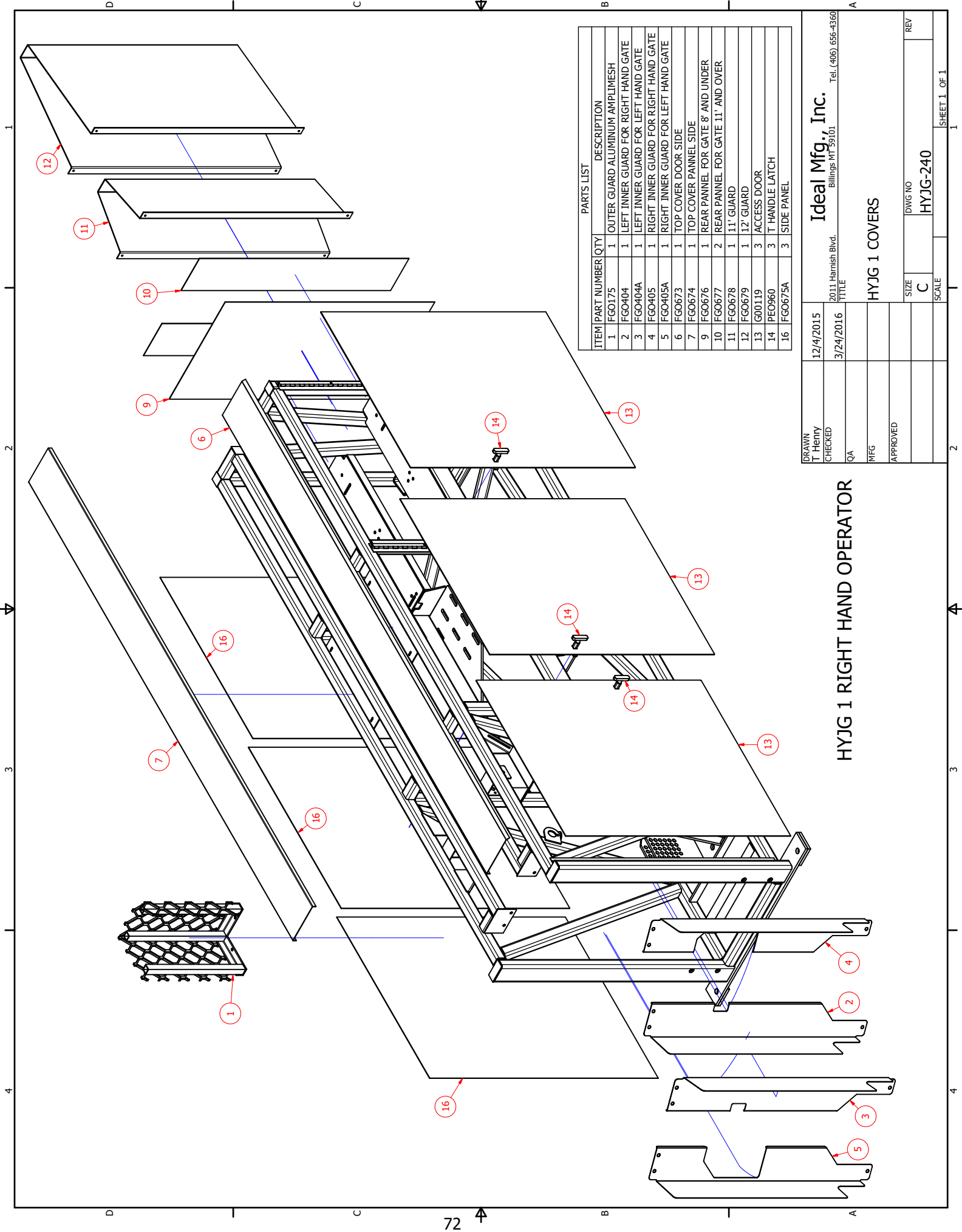

ITEM	PART NUMBER	QTY	DESCRIPTION
1	FGO175	1	OUTER GUARD ALUMINUM APPLIMESH
2	FGO404	1	LEFT INNER GUARD FOR RIGHT HAND GATE
3	FGO404A	1	LEFT INNER GUARD FOR LEFT HAND GATE
4	FGO405	1	RIGHT INNER GUARD FOR RIGHT HAND GATE
5	FGO405A	1	RIGHT INNER GUARD FOR LEFT HAND GATE
6	FGO673	1	TOP COVER DOOR SIDE
7	FGO674	1	TOP COVER PANNEL SIDE
9	FGO676	1	REAR PANNEL FOR GATE 8' AND UNDER
10	FGO677	2	REAR PANNEL FOR GATE 11' AND OVER
11	FGO678	1	11' GUARD
12	FGO679	1	12' GUARD
13	G00119	3	ACCESS DOOR
14	PEO960	3	T HANDLE LATCH
16	FGO675A	3	SIDE PANNEL

DRAWN	12/4/2015	<b>Ideal Mfg., Inc.</b>	
CHECKED	T Henry	2011 Harmish Blvd. Billings MT 59101 Tel. (406) 656-4360	
QA	3/24/2016	TITLE	
MFG		HYJG 1 COVERS	
APPROVED		SIZE	DWG NO
		C	HYJG-240
		SCALE	REV

**HYJG 1 RIGHT HAND OPERATOR**

## TILT-A-WAY HYDRAULIC OPERATOR PROPORTIONAL VALVE DRIVER SETTINGS

The Lynch Electronics Digital Display Proportional Valve Driver has been set at Ideal Mfg., Inc. and should not need any adjustments.

If for some reason the settings need to be checked, or reset the following are the Ideal Mfg., Inc. suggested settings.  
SET-UP (see page 61 drawing #HY JG-236)

1. Turn the power off (ref #1), remove the red wire on the motor control board from the Solenoid Valve output terminal for the direction needing adjustment (ref #2) (open solenoid / close solenoid). Only adjust one Solenoid Valve Driver at a time.
2. Connect the red wire removed from the motor control board to the 24 Volt DC terminal on the motor control board (ref #3).
3. Turn the power on (ref #1). Locate the Solenoid Valve Drive that power is being supplied to (ref #4). Remove screw that holds the Solenoid Valve Drive to the Proportional Valve Coil. Unplug the Solenoid Valve drive from the coil, pull straight out.
4. At power up, the display will show either the output current signal or the input signal (Default display setting shows the output signal).
5. Rotate SELECT to enter the set-up mode.
6. When you reach the setting you want to modify, rotate ADJUST up or down to the desired value.
7. To modify another setting, rotate SELECT again and repeat.
8. The Driver is fully functional during the set-up procedure with any adjustments effective immediately.
9. In order to write the new settings in the memory and return to normal mode of operation, rotate SELECT until the display shows SA, and then rotate ADJUST or wait for 100 seconds.
10. If you do not want to save the new settings you have just modified, you must disconnect the Driver from the power supply before the end of the 100 seconds to restore the previous settings.
11. After saving parameters to memory, the decimal point will be flashing and the Driver display will be back showing either the output current signal or input signal depending on your di selection.
12. To start over completely, you can restore the Lynch factory settings by rotating SELECT to rFP and then rotate ADJUST up past 10 for the display to reset. (NOTE for Step 9: You may have to adjust your Input Signal Setting Again if you reset to factory settings.)
13. When settings are set turn power off, install Solenoid Valve Driver on coil, and secure with screw removed. Disconnect red wire for 24 Volt DC terminal, and return it back to the terminal on the motor control board. Repeat for the other Solenoid Valve Driver is needed. Be sure to remove jumper wire if used before turning power back on.
14. Turn power on and operate the gate to check if adjustments are acceptable. Repeat if needed.

Display	Description	Close setting	Open setting
Hi:	HIGH, Maximum Current Output. (Amps) do not set above 1.6	1	1
Lo:	LOW, Minimum Current Output. (Amps) (See: NOTE 1)	0.4	0.43
rUP:	RAMP UP, Time for Output to increase from min to max. (Sec)	0.2	0.2
rDN:	RAMP DOWN, Time for Output to decrease from max to min. (Sec)	0.6	0.6
Cdb:	COMMAND DEADBAND, Output disabled if command signal less than dead band. (%)	0	0
dFr:	DITHER FREQUENCY, (Hz)	180	180
in:	INPUT SIGNAL SELECTION, 5 (0 to 5V) or 10 (0 to 10V) or 420 (4 to 20mA)	5	5
di:	DISPLAYED SIGNAL FOR TROUBLESHOOTING, 0 (command signal in [volts] or [milliamps]) or 1 (solenoid current in [amps]) **Flashing decimal point is an indicator for present display mode** -Fast Flashing decimal point, several flashes per second indicates di = 0 -Slow Flashing decimal point, 1 per second indicates di = 1 -No Flashing decimal point or No decimal point indicates display in SETTING/ADJUST mode	1	1
SA:	SAVE SETTINGS		
rFP:	RESET FACTORY PARAMETERS (See: NOTE 2)		
Err:	ERROR DETECTION STATE, Short Circuit, Reverse polarity protection and detection Error 0 – No Errors Error 1 – Overcurrent in driver likely due to short circuit in Solenoid Error 2 – Current exceeding 20 mA in “4 to 20 mA” input mode		
Clr:	CLEAR ERROR, clears Driver of Error State (See: NOTE 2)		

NOTE 1: When adjusting the HI and LO parameters, note the HI parameter value cannot be adjusted below the LO parameter value as well the LO parameter value cannot exceed the HI parameter value.  
NOTE 2: Adjust Parameter Value up past 9 to operate this command setting.

**TILT-A-WAY HYJG 1**  
**PROPORTIONAL VALVE DIAGRAM**  
 NOT ALL COMPONENTS AND WIRES SHOWN  
 FOR CLARITY  
 24 VOLT DC UNIT SHOWN  
 USE SAME PROCEDURE FOR AC UNIT

**ENCLOSURE**

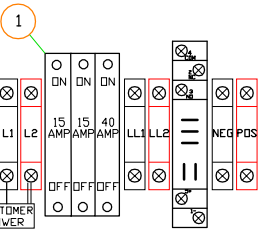
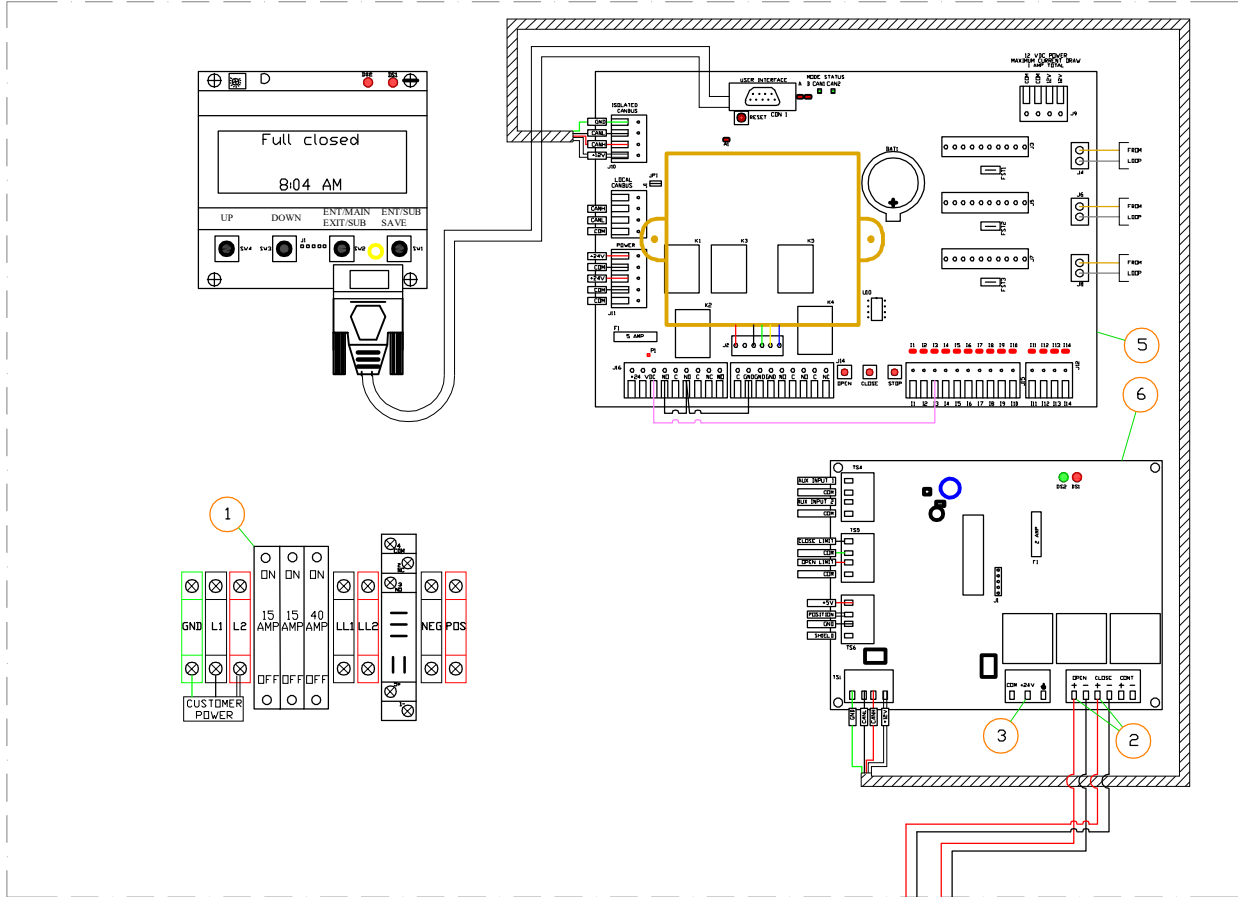

**SOLENOID VALVE DRIVER**

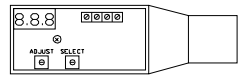

**HYDRAULIC PUMP UNIT**

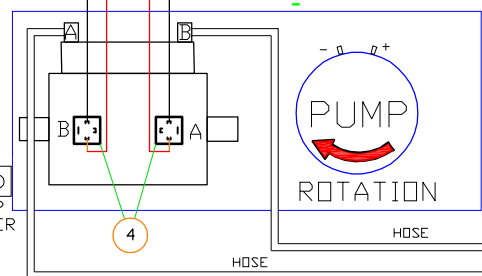

REPLACE FUSES WITH SAME TYPE AND RATING

DATE	REVISIONS	IDEAL MANUFACTURING INC.
		2011 WENSHI BLVD, BILLY, NY 5801
		TILT-A-WAY HYJG
		24 VOLT DC
		SOLENOID VALVE DRIVER

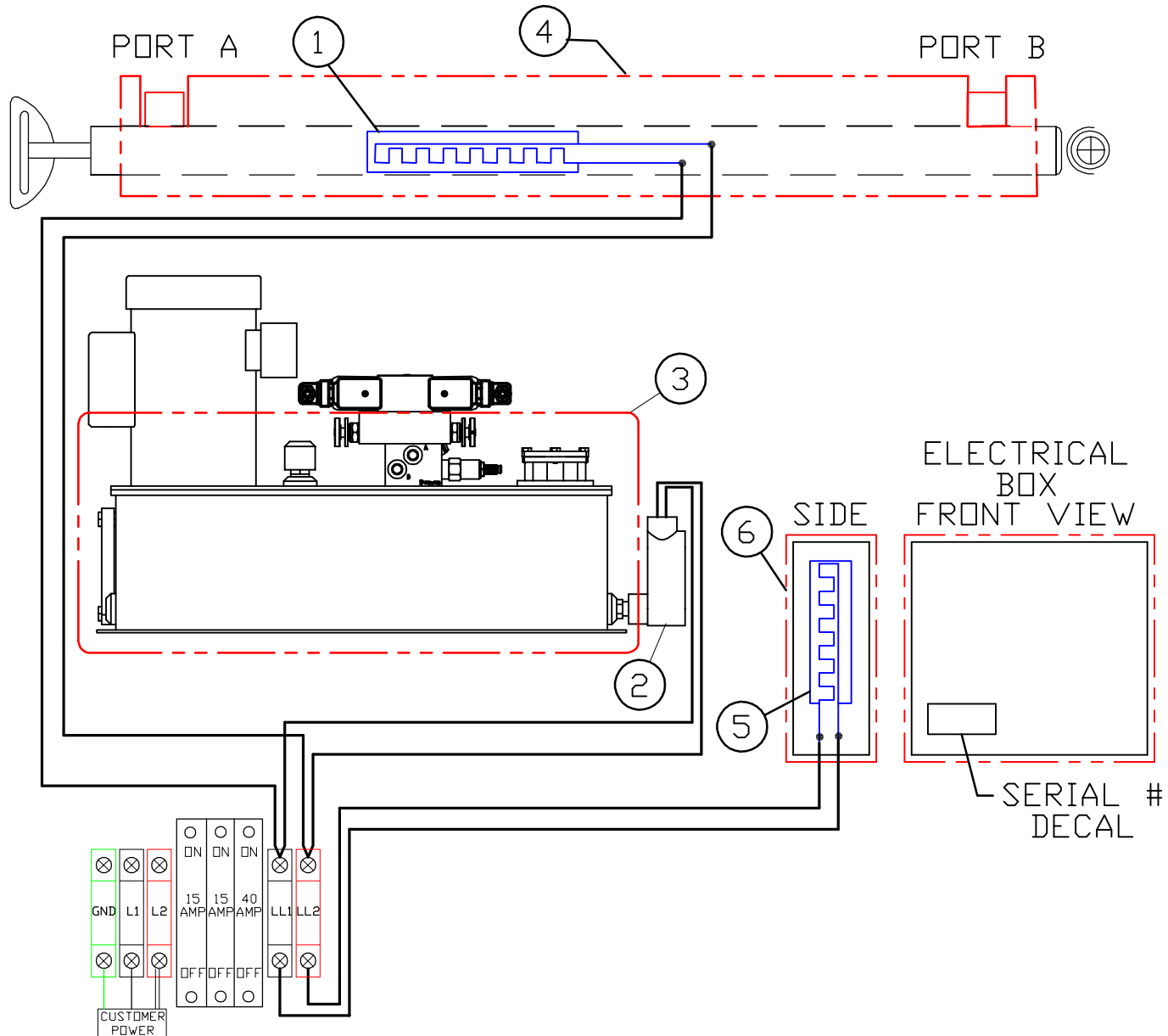

**TILT-A-WAY HYDRAULIC VERTICAL PIVOT GATE  
HYJG 1  
COLD WEATHER PACKAGE  
24 VDC 120 VAC**

REF. NO.	PART NO.	DESCRIPTION	REQ. NO.
1	PEO247	Cylinder Heating Strip	1
2	TWO462	In Tank Oil Heater with Thermostat (120 VAC)	1
3	100135	Hydraulic Pump & Reservoir Insulating Cover	1
4	100134	Cylinder Insulating Cover	1
5	PEO252	Electrical Box Heating Strip	1
6	N/A	Electrical Box Insulating Cover	1

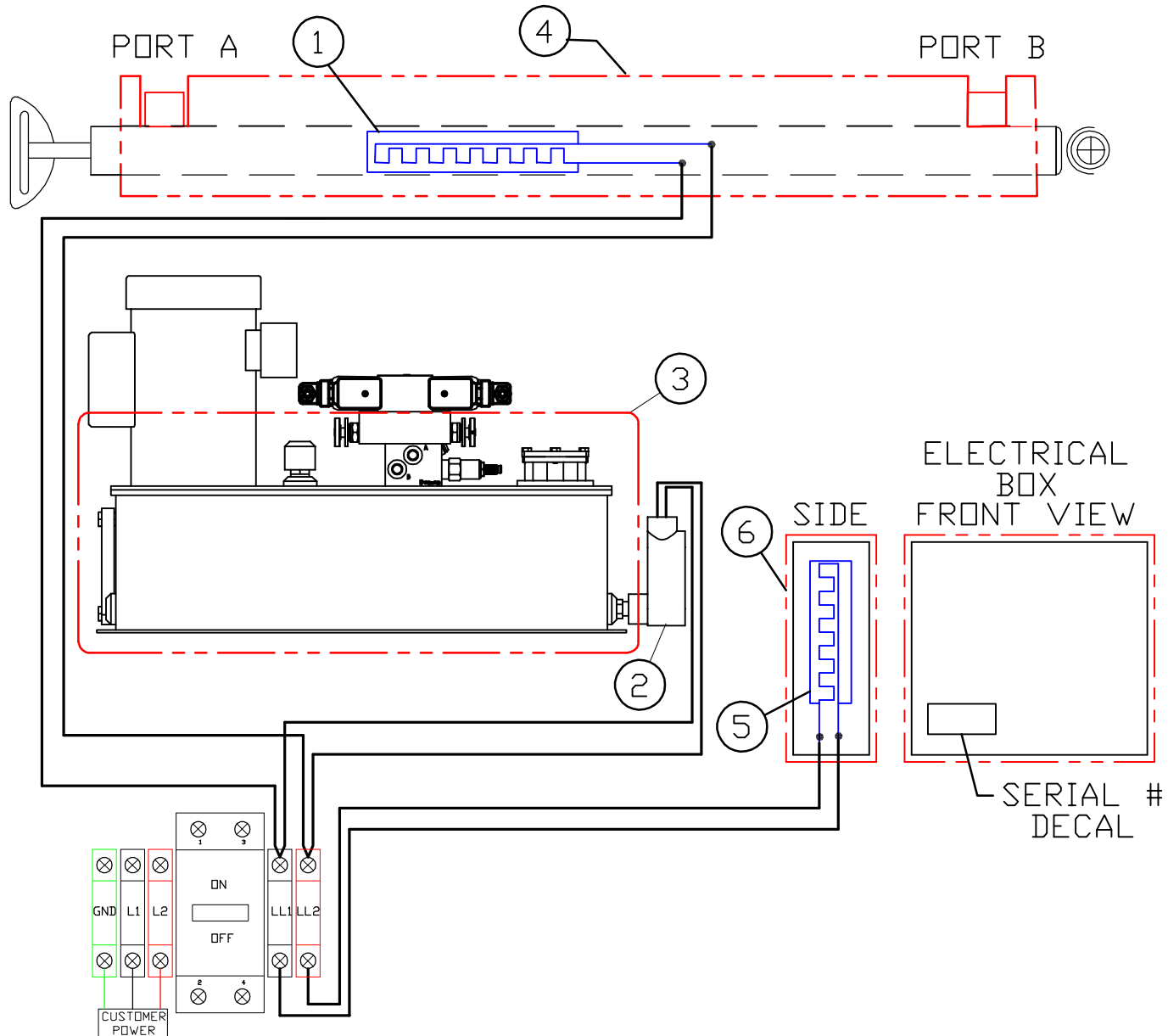

**TILT-A-WAY HYDRAULIC VERTICAL PIVOT GATE**  
**HYJG 1**  
**COLD WEATHER PACKAGE**  
**208 / 240 VAC SINGLE PHASE**

REF. NO.	PART NO.	DESCRIPTION	REQ. NO.
1	PEO247	Cylinder Heating Strip	1
2	TWO520	In Tank Oil Heater with Thermostat	1
3	100135	Hydraulic Pump & Reservoir Insulating Cover	1
4	100134	Cylinder Insulating Cover	1
5	PEO252	Electrical Box Heating Strip	1
6	N/A	Electrical Box Insulating Cover	1

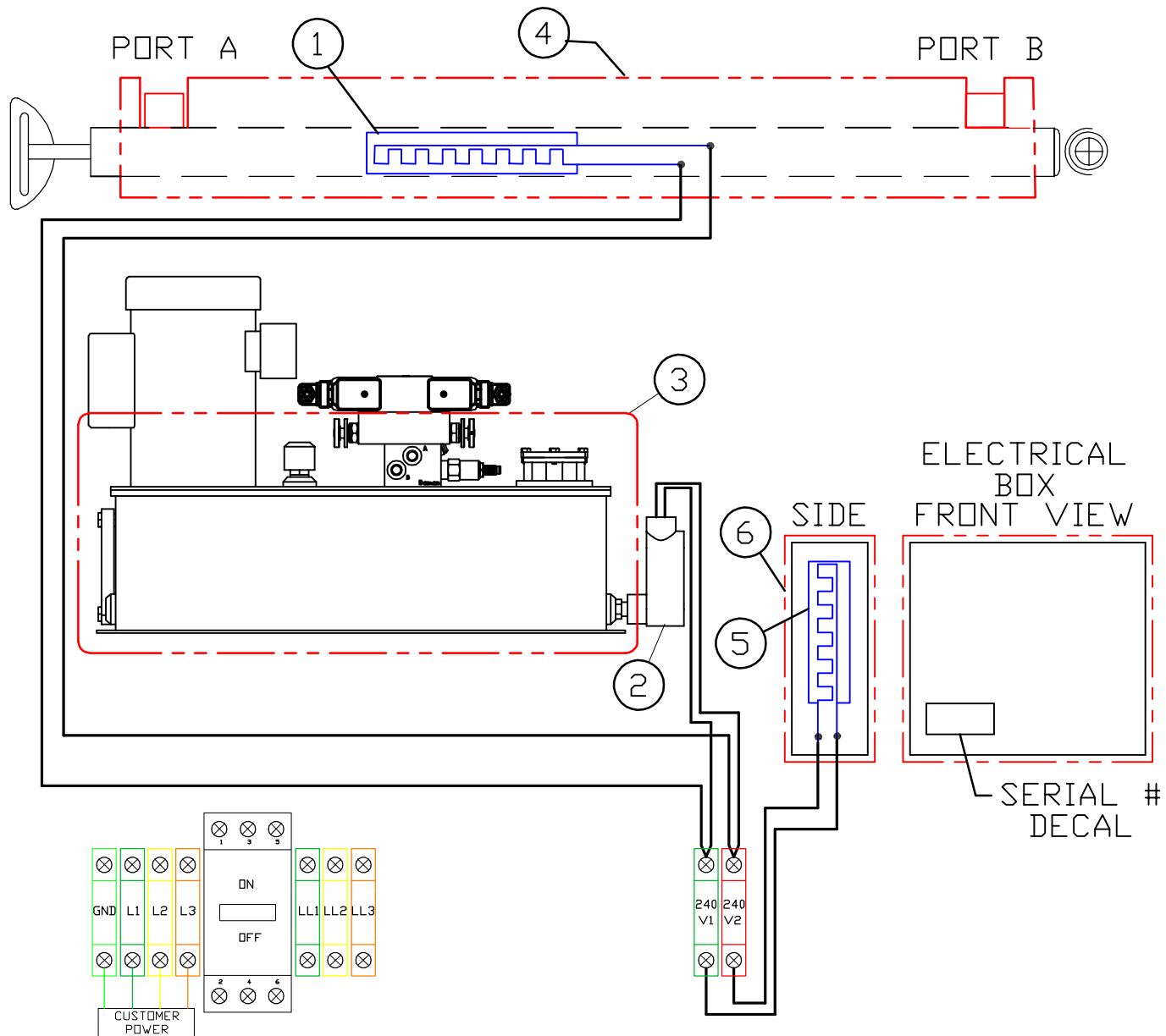

**TILT-A-WAY HYDRAULIC VERTICAL PIVOT GATE**  
**HYJG 1**  
**COLD WEATHER PACKAGE**  
**208 / 240 VAC THREE PHASE AND**  
**460 / 480 VAC THREE PHASE**

REF. NO.	PART NO.	DESCRIPTION	REQ. NO.
1	PEO247	Cylinder Heating Strip	1
2	TWO520	In Tank Oil Heater with Thermostat	1
3	100135	Hydraulic Pump & Reservoir Insulating Cover	1
4	100134	Cylinder Insulating Cover	1
5	PEO252	Electrical Box Heating Strip	1
6	N/A	Electrical Box Insulating Cover	1



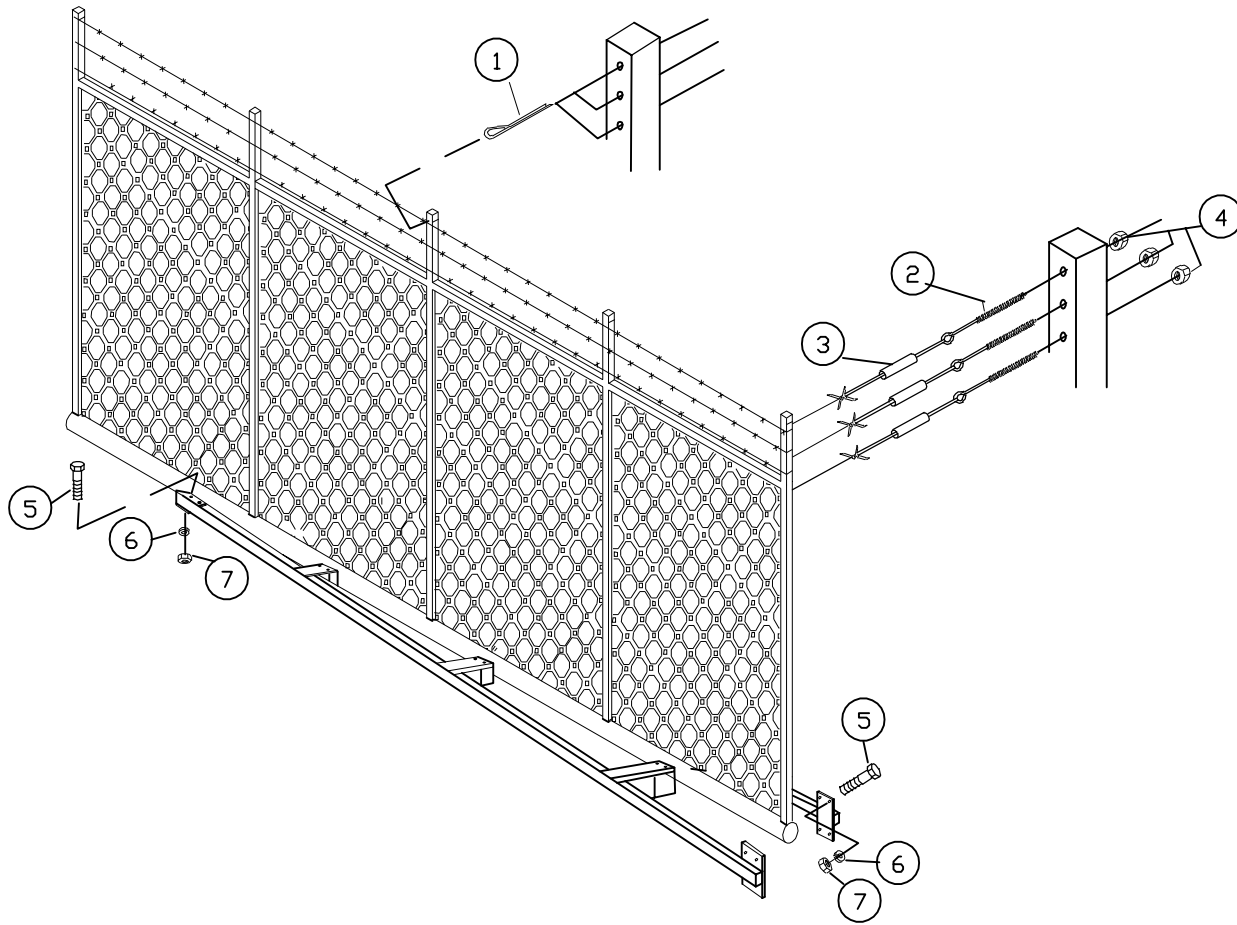

**TILT-A-WAY  
HYDRAULIC VERTICAL PIVOT GATE  
BARRIER UNIT  
HYJG 1**

REF NO.	PART NO.	DESCRIPTION	REQ NO
		Serial # decal is located on the front of the electrical enclosure.	
		Barrier assemblies are manufactured from steel or aluminum material and in varied lengths and heights.	
		When contacting manufacturer regarding a TILT-A-Way gate, always provide complete serial number.	
1	ID1066	3/16" x 2 1/2" Stainless Steel Cotter Pin - 3 per inside tube	
2	ID1063	5/16 x 4" Eye Bolts (3 per end)	6
3	ID1064	Wire Crimp	6
4	N/A	5/16" Hex Nut	6
5	N/A	3/8" x 2 1/4" Hex Bolt for Aluminum Brace or 3/8" x 2" Hex Bolt for Steel Brace	6
6	N/A	3/8" Lock Washer	6
7	N/A	3/8" Hex Nut	6

**TILT-A-WAY HYDRAULIC VERTICAL PIVOT GATE  
OPERATOR FIELD INSTALLATION  
DRAWING # HYJG-241 PAGE 67  
HYJG 1**

<b>REF. NO.</b>	<b>DESCRIPTION</b>
-----------------	--------------------

**Note: If gate does not operate on first try, but hydraulic pump runs  
switch 2 power lines to reverse pump rotation.**

1. Control pedestal **HYJG**
2. Concrete support slab Minimum dimensions 11'0" long x 4'0" wide x 1'6" thick.  
To be placed on firm soil or compacted fill, reinforced with #4 rebar each way; and cement piling dug to frost line by purchaser  
NOTE: Will withstand and estimated 100 MPH wind in most soil conditions.
3. Electrical conduit area. Stub in electrical supply, 20 Amp service.
4. Four anchor bolts ¾" diameter X 12" with 2" projection.
5. Two base plates, welded to pedestal.

---

**TILT-A-WAY  
HYDRAULIC OPERATOR INSTALLATION PROCEDURE FOR GATE THAT IS  
SHIPPED UNASSEMBLED**

1. Remove all materials used for protection during shipment.
2. Place pedestal on concrete pad. Align and level pedestal, drill four holes minimum 10" deep. Epoxy ¾" x 12 studs in holes. Follow epoxy manufacturers instructions.
3. Open rear access door to expose spring tension adjustment screws.
4. Find two fluid bypass valves, place in open position.
5. Back off spring tension screws to provide slack in tension cables. (1 5/8" socket needed)
6. Rotate barrier carriage to down position. Remove pivot shaft with attached components. Install barrier and secure to vertical carriage post with five bolts and one bolt at outer end of carriage horizontal channel.
7. Place plastic rub washer over pivot shaft collar on carriage. Align cylinder rod end bearing with collar and insert pivot shaft from far side. Secure with flat washer, lock washer and bolt.
8. Tighten spring tension screws while inspecting cables for proper wrap around balance sheaves. When slide members have reached marks indicated on tracks. Proper balance tension will have been achieved. If at a later date minor adjustment should be required, refer to balance system adjusting section.
9. Perform required electrical connections in accordance with diagrams shown in this manual.
10. Position fluid bypass valves to closed setting, close and secure access door.
11. If gate fails to function properly, contact manufacturer's representative.

**TILT-A-WAY  
HYDRAULIC OPERATOR INSTALLATION PROCEDURE FOR GATE THAT IS  
SHIPPED ASSEMBLED**

1. Remove all materials used for protection during shipment.
2. Place operator and barrier on concrete pad. Align and level pedestal, drill four holes minimum 10" deep. Epoxy ¾" x 12 studs in holes. Follow epoxy manufacturers instructions.
3. Perform required electrical connections in accordance with diagrams shown in this manual.
4. Position fluid bypass valves to closed setting, close and secure access door.
5. If gate fails to function properly, contact manufacturer's representative.

# MODEL HYJG HYDRAULIC VERTICAL PIVOT GATE

SEE PAGE 2 FOR RECOMMENDED WIRE SIZE

**\*NOTE: IF BARRIER HEIGHT EXCEEDS 10' TALL \*  
CLEARANCE FOR BARRIER GUARD IS REQUIRED**

MAXIMUM BARRIER HEIGHT FOR BARRIER LENGTH TABLE	
BARRIER HEIGHT	BARRIER LENGTH
12' TALL	19' LONG
11' TALL	21' LONG
10' TALL	23' LONG
9' TALL	25' LONG
8' TALL	25' LONG
7' TALL	25' LONG
6' TALL	27' LONG
5' TALL	28' LONG
4' TALL	29' LONG

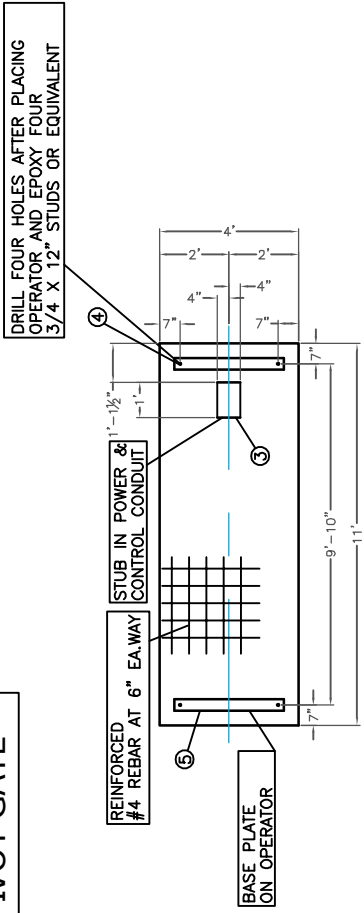

## FOUNDATION

PROVIDE 40" MINIMUM CLEARANCE FOR MAINTENANCE ACCESS DOOR SWING

PROVIDE 14" MINIMUM CLEARANCE FOR 11' TALL BARRIER GUARD  
PROVIDE 26" MINIMUM CLEARANCE FOR 12' TALL BARRIER GUARD

## SECURED SIDE

## ROADWAY

SEE MAX BARRIER HEIGHT FOR BARRIER LENGTH TABLE

PLACE FENCE END POST IN CONCRETE FOOTING WITH STANCHION

FENCE TO SUIT

FENCE TO SUIT

BRASS GROUNDING CONNECTION ON PEDESTAL

NOTE:  
FOR 24 VDC OPERATORS ALLOW CLEARANCE FOR BATTERY INSTALLATION AND MAINTENANCE

NOTE:  
BARRIER GUARD CLEARANCE IS REQUIRED IF BARRIER HEIGHT EXCEEDS 10' ABOVE FOUNDATION

PROVIDE 14" MINIMUM CLEARANCE FOR 11' TALL BARRIER GUARD  
PROVIDE 26" MINIMUM CLEARANCE FOR 12' TALL BARRIER GUARD

BRASS GROUNDING CONNECTION ON PEDESTAL

LEFT HAND INSTALLATION SHOWN  
RIGHT HAND INSTALLATION SHOWN

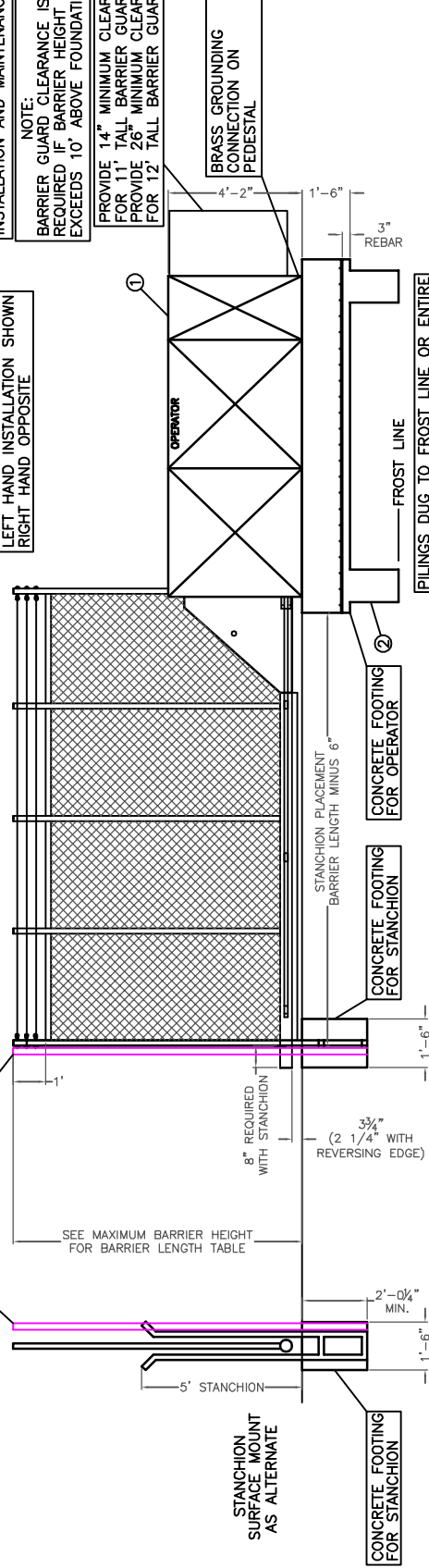

NOTE: FOR ADDITIONAL GROUND CLEARANCE RAISE FOUNDATION

NOTE: BARRIER STYLE WITHIN DIMENSIONAL LIMITS AS PER CUSTOMER SPECIFICATIONS. FOR GREATER ROADWAY SPAN INSTALL OPPOSING GATES PROVIDE 1' GAP.

PILINGS DUG TO FROST LINE OR ENTIRE CONCRETE PAD DUG TO FROST LINE

IDEAL MANUFACTURING INC.  
2011 HARNISH BLVD. BILLINGS, MT 59101  
PHONE: (406) 656-4360  
VERTICAL PIVOT GATE  
BASIC DIAGRAM  
AUTO. CAD. DWG. #HYJG-241

**TILT-A-WAY  
HYJG 1 HYDRAULIC OPERATOR  
BALANCE SYSTEM ADJUSTMENT  
DRAWING HYJG-242**

**TILT-A-WAY road gate must be balanced to offer the least amount of resistance against movement at both up and down extreme positions or combination of both.**

**Balance adjustment is accomplished by cable tension, cable sheave position or combination of both.**

**Two cable systems are incorporated in the balance system. Adjustments performed at one side may require adjustments on the opposite side.**

**SAFETY WARNINGS-VERY IMPORTANT**

- 1. Before performing any maintenance or adjustment, open power disconnect switch located inside control panel enclosure. Prior to performing any adjustment, hydraulic fluid bypass valves must be placed in open position.**
- 2. Any adjustment performed on cable sheave must be preceded by the release of all cable tension at spring connections.**

**CONDITIONS AND SOLUTIONS**

- 1. Condition: Gate heavy at both up and down positions.  
Solution: Increases cable tension.**
- 2. Condition: Gate light at both up and down positions  
Solution: Decrease cable tension.**
- 3. Condition: Gate heavy at down position only.  
Solution: Lower cable sheave and increase cable tension.**
- 4. Condition: Gate light at down position only.  
Solution: Raise cable sheave and decrease cable tension.**
- 5. Condition: Gate heavy at up position only.  
Solution: Raise cable sheave and decrease cable tension.**
- 6. Condition: Gate light at up position only.  
Solution: Lower cable sheave increase cable tension.**
- 7. Condition: Gate heavy at intermediate positions.  
Solution: Move cable sheave forward.**
- 8. Condition: Gate light at intermediate positions.  
Solution: Move cable sheave rearward.**

BARRIER NOT SHOWN  
SOME FRAME TUBE REMOVED  
FOR CLARITY

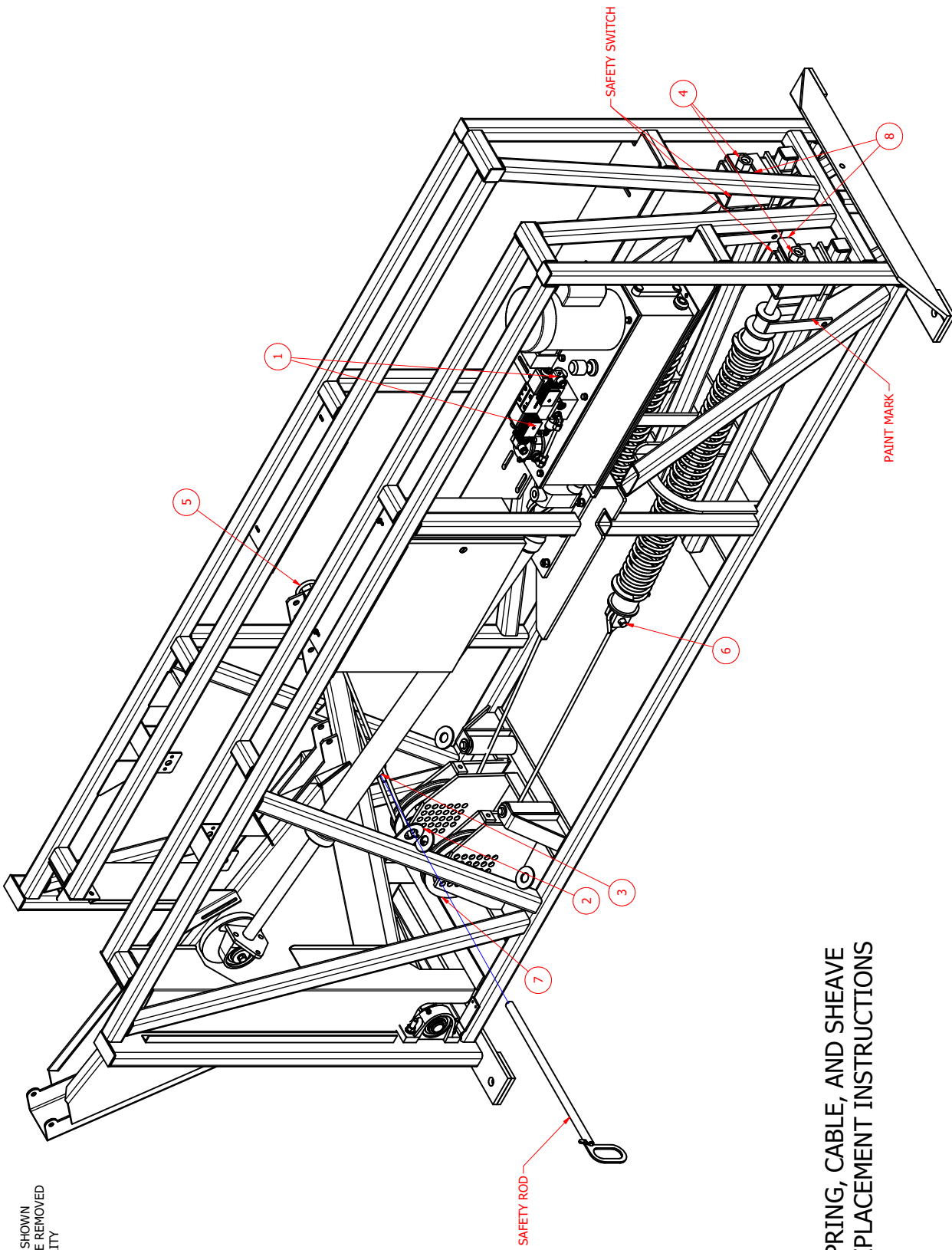

SPRING, CABLE, AND SHEAVE  
REPLACEMENT INSTRUCTIONS

DRAWN	12/7/2015	Ideal Mfg., Inc.	
T. Henry		Billings MT 59101 Tel. (406) 656-4360	
CHECKED	3/24/2016	TITLE	
QA		HYJG 1 SPRING REPLACEMENT	
MFG		SIZE	DWG NO
APPROVED		C	HYJG-243
		SCALE	REV
			SHEET 1 OF 1

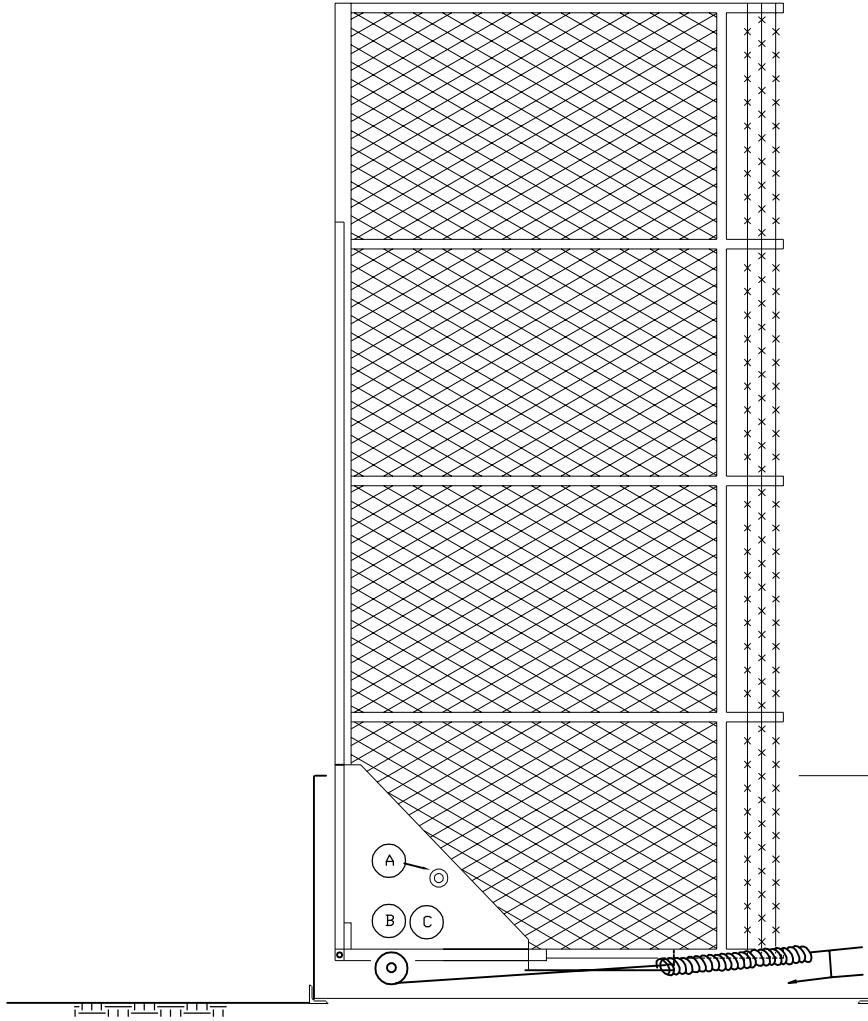

UP

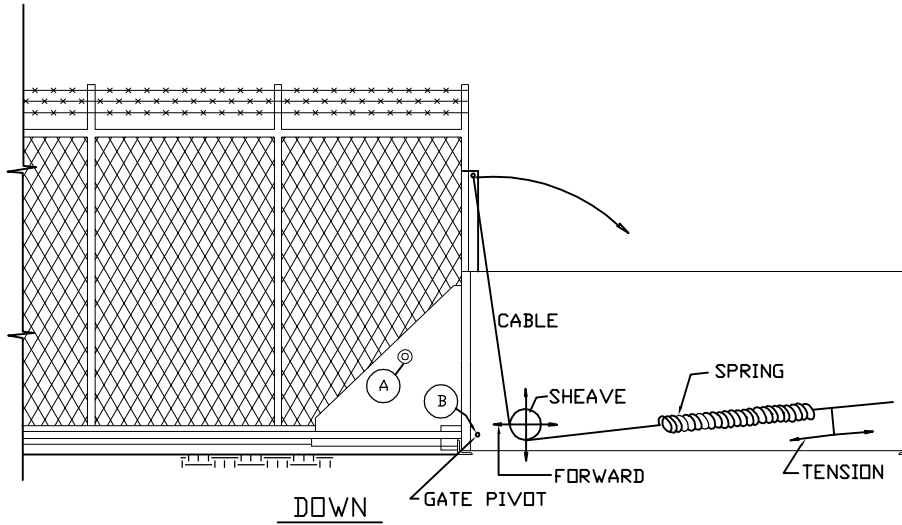

DOWN

TILT-A-WAY HYDRAULIC VERTICAL PIVOT GATE  
HYJG  
BALANCE SYSTEM ADJUSTMENT

## TILT-A-WAY HYDRAULIC VERTICAL PIVOT GATE BALANCE SYSTEM CABLE, SPRING, AND SHEAVE REPLACEMENT INSTRUCTIONS

**NOTE: TURN POWER OFF BEFORE REPLACING BALANCE SYSTEM COMPONENTS. WHEN REPLACING BALANCE SYSTEM COMPONENTS ALWAYS CHECK THE SHEAVE BEARINGS, AND REPLACE IF NEEDED. MAKE SURE THE TENSION CABLE IS IN THE GROOVE OF CABLE SHEAVE WHEN TIGHTENING THE SPRING.**

1. Open access doors, and turn power off. If cable, or spring that is being replaced is on the opposite side from access doors remove side panel on that side.
2. Open both manual bypass valves on hydraulic pump unit, (ref # 1). Manually raise barrier to about 50 degrees. Place the safety rod thru the three brackets to secure barrier. Two brackets welded to the frame, (ref # 2), and one bracket welded to the carriage, (ref # 3).
3. Check for paint mark on square tube under tension spring by upper spring end. If there is no mark to indicate spring tension, make one to insure the spring is tightened to proper tension for balance.
4. Lubricate spring tension screw. Use a 1 5/8" socket to turn tension screw nut counter clockwise to loosen spring, and clockwise to tighten spring, (ref # 4).
5. **To replace broken cable.** Remove cotter pin from pin at the top of the carriage (ref # 5). Remove flat washer, and cable. Remove cotter pin from pin on lower spring end (ref # 6) Remove pin, and cable. Check bearings in sheaves, and route the cable under the front sheave (ref # 7). It may be necessary to remove the front sheave to get the cable under it. If the sheave must be removed to replace cable make note of the hole the shoulder bolt passes thru. Place eye of cable on pin of carriage, and install flat washer, and cotter pin. Pull loose end of cable towards spring end. Make note of how far spring end must move to reach the free end of cable. Turn tension screw nut counter clockwise until the cable can be attached to spring end. Install the pin thru spring end, and cable eye. Secure with cotter pin. Be sure that the safety switch plate is aligned with safety switch when tension springs are tightened (ref # 8). Turn tension spring nut clockwise until upper spring end reaches the mark on the square tube. Remove safety rod, reattach position linkage, and check balance. Adjust accordingly. For balancing instructions see page 68.
6. **To replace broken spring.** Remove cotter pin from pin on lower spring end (ref # 6). Inspect cable for broken strands. If there are 5 broken strands per lay, or 10 over all replace cable. Before unwinding spring refer to # 2, and 3 above. Turn tension screw nut counter clockwise until upper spring end comes off tension screw. If your replacement spring did not come with spring ends then you must reuse the ends from your broken spring. Start the new spring on the tension screw, and connect the cable using pin, and secure with cotter pin. Turning the tension screw nut clockwise watch the cable to make sure it is in the groove of the sheave. Also be sure that the safety switch plate is aligned with safety switch (ref # 8). Tighten the spring up to the mark on the square tube. Remove safety rod, reattach position linkage, and check balance. Adjust accordingly. For balancing instructions see page 43.
7. **To replace sheave.** Before unwinding spring refer to #2, and 3 above. Turn tension screw nut counter clockwise until there enough slack in cable to rotate the sheave freely by hand. Make note of the hole the shoulder bolt goes thru. Remove nylock hex nut and shoulder bolt. Remove the sheave, and replace with new sheave. Reinstall shoulder bolt, and nylock hex nut. Turning the tension screw nut clockwise watch the cable to make sure it is in the groove of the sheave. Also be sure that the safety switch plate is aligned with safety switch (ref # 8). Remove safety rod, reattach position linkage, and check balance. Adjust accordingly. For balancing instructions see page 43.
8. After checking balance, and adjusting the balance close the manual bypass valves.
9. Turn power on. Cycle gate open, and closed to check for proper operation. Close and lock access doors.

**TILT-A-WAY HYDRAULIC VERTICAL PIVOT GATE  
GENERAL ARRANGEMENT AND MAINTENANCE  
MAINTENANCE MUST BE DONE EVERY 5000 OPERATIONS OR YEARLY  
HYJG 1  
DWG # HYJG-244**

<b>REF NO.</b>	<b>DESCRIPTION</b>	
1	Control Pedestal Frame	For covering. See Drawing HYJG-240 Page 65
2	Barrier Unit	See Drawing HYJG-248 Page 81
3	Hydraulic Pump & Reservoir	See Drawing HYJG-252, 254 Page 88 thru Page 91
4	Electrical Control Enclosure 24 VDC 120 VAC 208 / 240 VAC Single Phase 208 /240 VAC Three Phase 480 VAC Three Phase	See Drawing HYJG-204 Page 9 See Drawing HYJG-207 Page 13 See Drawing HYJG-210 Page 17 See Drawing HYJG-213 Page 21
5	Barrier Carriage	See Drawing HYJG-245 Page 75
6	Balance System Cable Sheave Assembly.	See Drawing HYJG-249 Page 84
7	Balance System Cable Guide Assembly.	See Drawing HYJG-250 Page 85
8	Balance System Tension Cable	See Drawing HYJG-249 Page 84
9	Balance system Tension Spring	See Drawing HYJG-251 Page 87
10	Balance System Spring Tension Adjusting Limit	See Drawing HYJG-251 Page 87
11	Balance System Spring Tension Release	“Power Off Safety Switch”. See Drawing HYJG-251 Page 87
12	Hydraulic Actuating Cylinder	See Drawing HYJG-246 Page 77
13	Cylinder Control Actuating System	See Drawing HYJG-247 Page 79, HYJG-253 Page 83

**TILT-A-WAY  
GENERAL MAINTENANCE  
HYJg-244**

**Check all safety devices for proper function monthly.**

Check interior of pedestal for any accumulation of trash caused by blowing wind and remove. **(Monthly)**.

The following maintenance steps should be preformed every 5000 operations or yearly.

1. Check hydraulic fluid level with site gauge on oil reservoir. Level to be approximately 2 ½” below the top of reservoir. If oil is required, add Citgo-CP hydraulic fluid (this hydraulic fluid is blue in color). Check oil level with cylinder retracted.
2. Clean and lubricate spring tension screws with “general purpose grease” to prevent rusting.
3. Lubricate with “general purpose grease such as a bearing grease” all points equipped with zerk fitting.
  - A. Barrier carriage pivot bearing. Two bearings one each side.
  - B. Cylinder anchor pivot.
  - C. Cylinder rod end pivot bearing.
4. Check gate balance. Open gate to mid travel, and stop. Turn power off, and open manual valves on front of hydraulic pump unit. Gate should remain at mid travel position. If gate moves see page 68 for balance adjustment. Close manual valves, and turn power on. Return gate to closed position.
5. Inspect balance cables for broken strands. Replace cable if there are five broken strands per lay or ten broken strands over all. See page 71 for cable replacement instructions.



REF # 2 BARRIER NOT SHOWN  
SEE PAGE 81

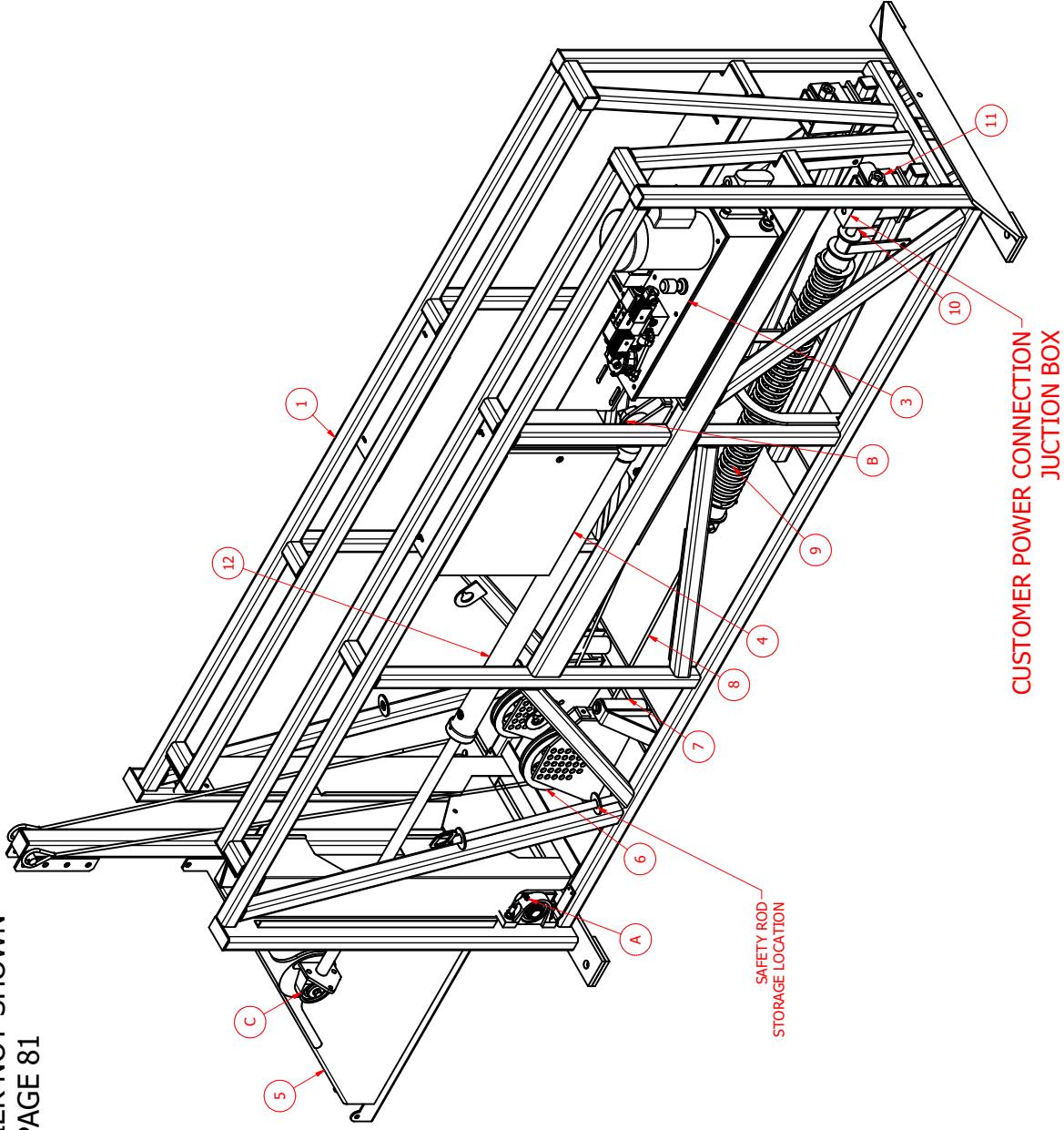

RIGHT HAND OPERATOR SHOWN  
LEFT HAND OPERATOR OPPOSITE

DRAWN T. Henry	12/7/2015	Ideal Mfg., Inc. 2011 Harnish Blvd. Billings MT 59101 Tel. (406) 656-4360	
CHECKED QA	4/4/2019	TITLE HYJG 1 GENERAL ARRANGEMENT	
APPROVED MFG		SIZE C	DWG NO HYJG-244
		SCALE	REV
			SHEET 1 OF 1

**TILT-A-WAY  
HYDRAULIC VERTICAL PIVOT GATE  
HYJG 1 BARRIER CARRIAGE**

**DRAWING HYJG-245**

<b>REF NO.</b>	<b>PART NO.</b>	<b>DESCRIPTION</b>	<b>REQ'D NO.</b>
1A	FGO147-C	Barrier Carriage Frame (standard)	1
1B	FGO147-B	Barrier Carriage Frame (short)	1
1C	FGO147-D	Barrier Carriage Frame (use with 1 1/2" x 3" hex bolt)	
2	TWO101	Pillow Block Bearing	2
3	N/A	1/2" Hex Nut	4
4	N/A	1/2" Lock Washer	4
5	N/A	1/2" SAE Flat Washer	4
6	N/A	1/2" X 4 1/2" Flat Head Bolt	4
7	N/A	1" SAE Flat Washer	4
8	ID1006	3/16" X 1 1/2" Stainless Cotter Pin	2
9	N/A	5/8" Nylock Nut	5-(1A) 1-(1B)
10	N/A	5/8" x 3 1/4" Hex Head Bolt	5-(1A) 1-(1B)
11	N/A	3/8" Hex Nut	12
12	N/A	3/8" Lock Washer	12
13	N/A	3/8" X 1 1/4" Hex Head Bolt	8
14	N/A	1/2" X 5 1/2" Hex Head Bolt	1
15	N/A	1/2" Nylock Nut	1
16	N/A	3/8"X 1 1/2" Hex Head Bolt	4
17	N/A	3/8" Flat Washer	8
18	FGO759	Steel Sway Brace Bracket	2

SHORT CARRIAGE

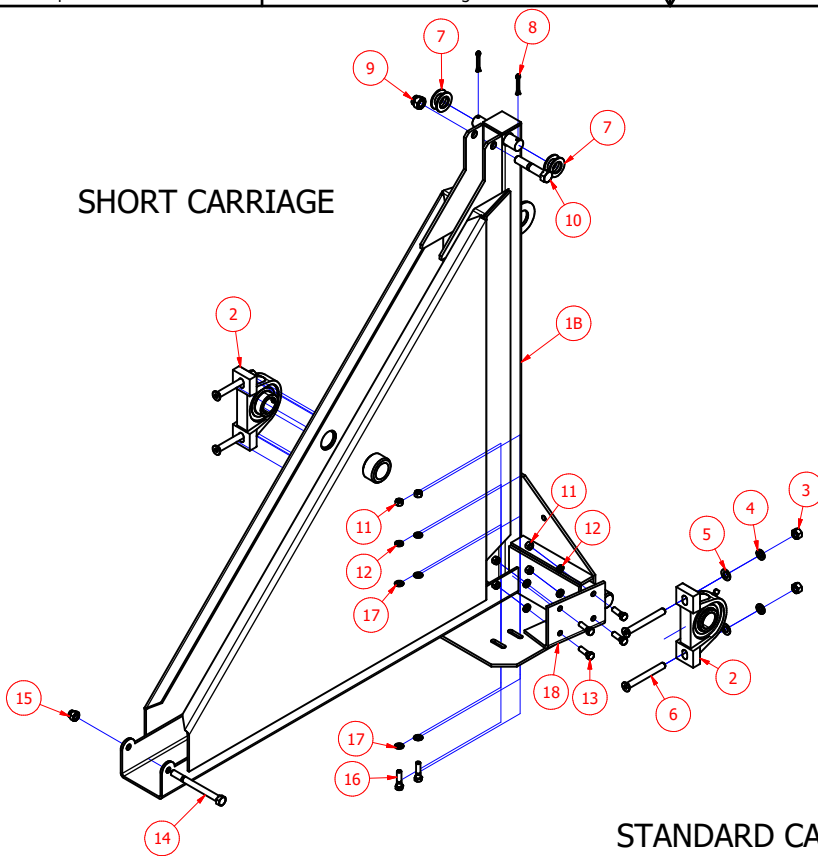

STANDARD CARRIAGE  
FGO147-D  
WITH 1 1/2" X 3"  
PIVOT HEX BOLT

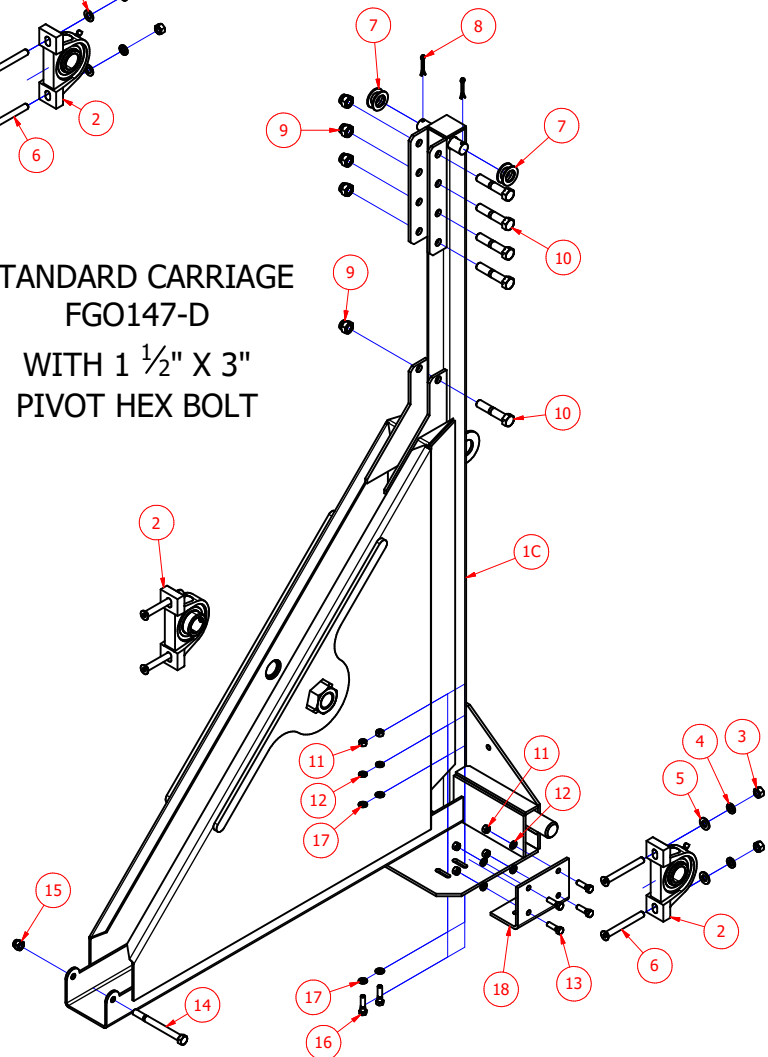

STANDARD CARRIAGE  
FGO147-C  
WITH 1 1/2" X 9 1/2"  
PIVOT PIN

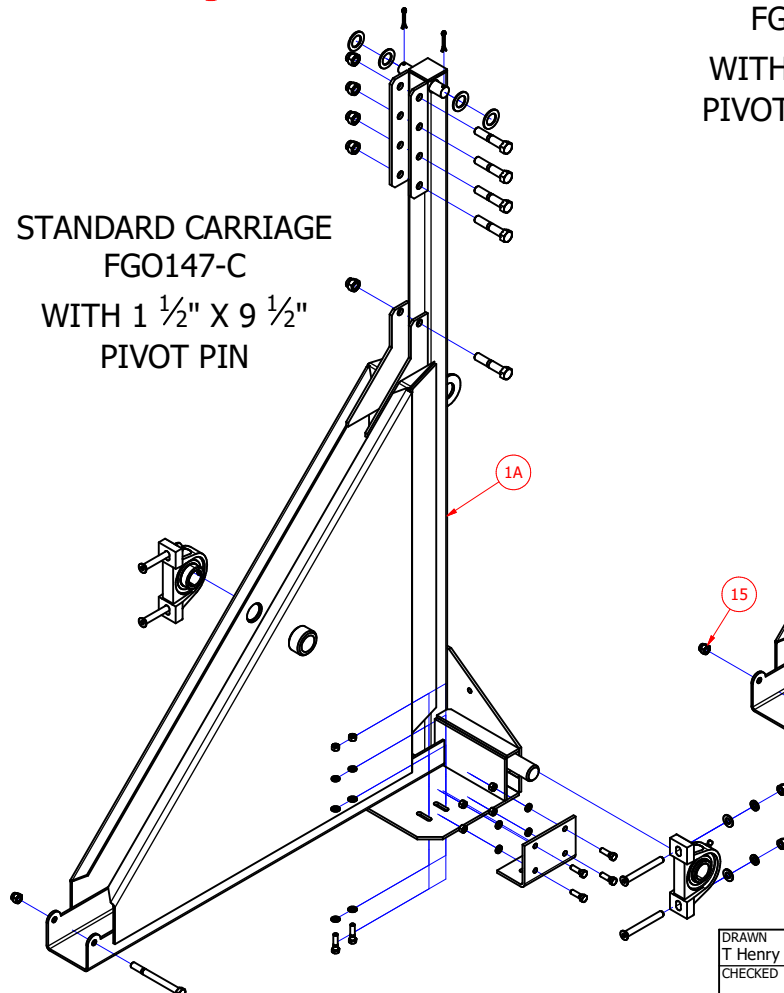

DRAWN T Henry	12/7/2015	Ideal Mfg., Inc. 2011 Harnish Blvd. Billings MT 59101 Tel. (406) 656-4360	
CHECKED	1/25/2019		
QA		TITLE	
MFG		HYJG 1 BARRIER CARRIAGE	
APPROVED		SIZE C	DWG NO HYJG-245
		SCALE	REV
		SHEET 1 OF 1	

**TILT-A-WAY HYJG 1  
HYDRAULIC CYLINDER WITH COMPONENTS**

ITEM	PART NUMBER	QTY	DESCRIPTION
1	100234	1	STRING POTENTIOMETER
2	100235	2	U BOLT
3	FGO194	1	PLASTIC RUNNER BEARING
4	FGO198	1	ROD END PIVOT SHAFT
5	FGO199	1	PLASTIC RUB WASHER
6	FGO208	1	BEARING SLEEVE PRESSURE WASHER
7	G00120	1	FOOT CLEVES
8	G00123	2	PLATE WASHER
9	G00137	1	ACTUATOR ROD HYJG
10	G00138	1	ACTUATING TRACK
11	G00141	2	LIMIT SWITCH MOUNTING PLATE
12	G00142	1	ACTUATOR BLOCK
13	G00152	1	POTENTIOMETER BRACKET
14	G00153	1	STRING BRACKET
15	ID1031	2	E Ring
16	NA	1	1 1/2 - 6 X 3 1/2 Hex Bolt
17	NA	1	1 1/2 - 6 Hex Jam Nut
18	NA	6	1/2 -13 Hex Nut
19	NA	6	1/2 Lock Washer
20	NA	6	1/2 - 13 X 1 3/4 Hex Bolt
21	NA	3	1/2 - 13 X 1 1/4 Hex Bolt
22	NA	1	6 ORB X 6 FJIC LONG 90 DEG
23	NA	1	6 ORB X 6 FJIC 90 DEG
24	NA	4	3/8 - 16 Hex Nut
25	NA	4	1/4 Lock Washer
26	NA	1	GREASE FITTING
27	NA	4	3/8 Lock Washer
28	NA	3	1/2 Lock Washer
29	NA	1	8 - 32 X 3/4 Machine Screw
30	NA	2	8 - 32 X 1 Machine Screw
31	NA	8	8 - 32 X 1 1/2 Machine Screw
32	NA	4	1/4 - 20 Hex Nut
33	NA	8	SPACER
34	NA	4	1/4 Flat Washer
35	NA	4	1/4 -20 X 1 Hex Bolt
36	NA	2	8 -32 X 1/2 Machine Screw
37	NA	2	8 - 32 X 3/8 Machine Screw
38	NA	16	8 - 32 Hex Machine Screw Nut
39	NA	16	NO. 8 Lock Washers
40	NA	2	3/4 - 10 Hex Nut
41	NA	1	3/4 Lock Washer
42	PEO963A	4	LIMIT SWITCH
43	TWO118	1	BEARING ROD END
44	TWO575-1	1	CYLINDER

TILT-A-WAY HYJG 1  
CYLINDER WITH COMPONENTS  
RIGHT HAND OPERATOR CYLINDER  
ASSEMBLY SHOWN

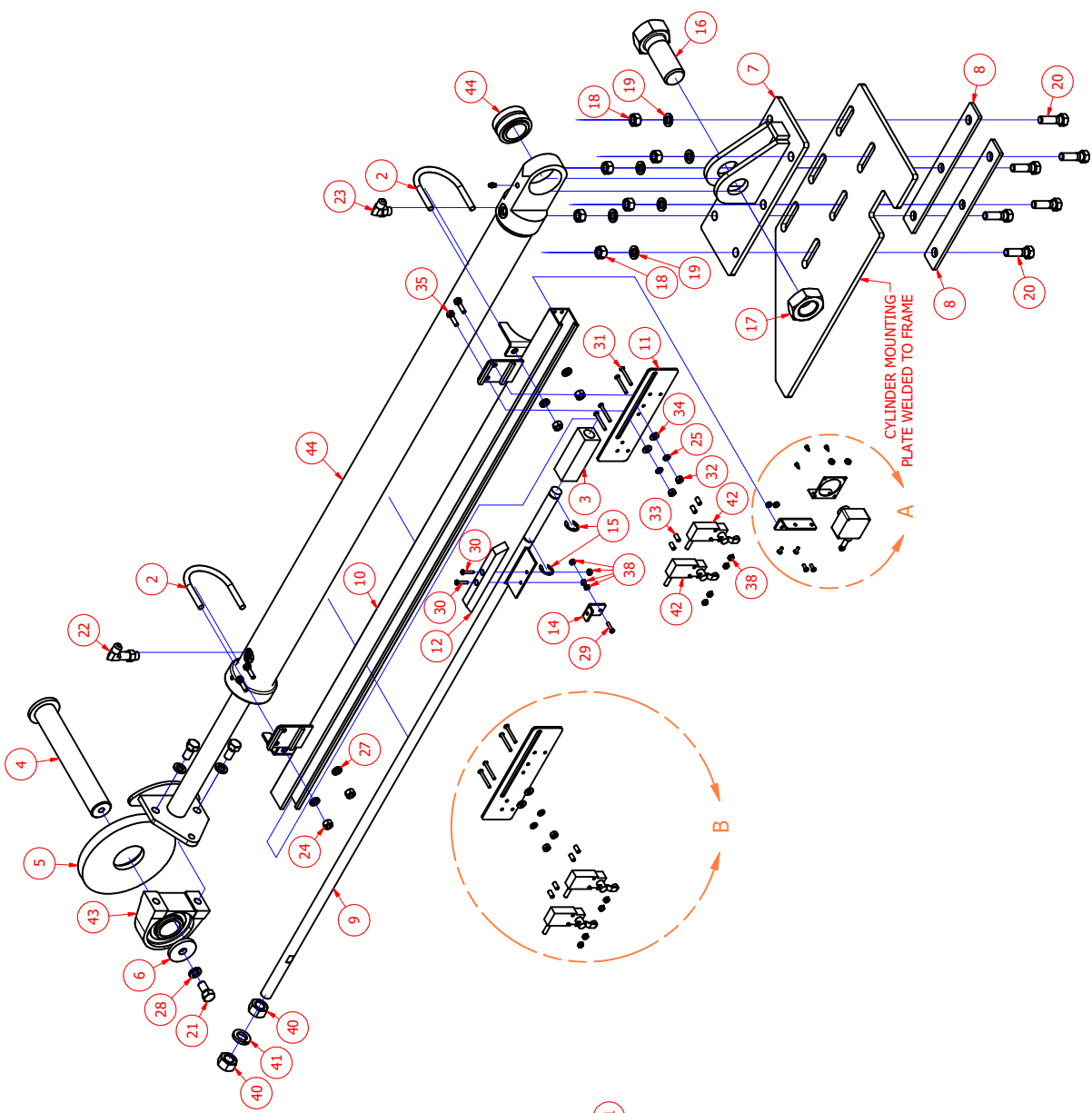

DETAIL B  
SCALE 1 / 3

DETAIL A  
SCALE 1 / 2

	PROJECTION	1/10/2020	2011 Harnish Blvd.	Billings MT 59101
	CHECKED			
	QA			
	MFG			
	MATERIAL			
	MASS			
	N/A			
	FRACTION			
	ANGLES			
	DRILLED HOLE			
REMOVE ALL BURRS UNLESS OTHERWISE SPECIFIED DIMENSIONS ARE IN INCHES TOLERANCES ARE: .XX .01 .XXX .005 FRACTION 1/32 ANGLES 1° DRILLED HOLE 1/64		DRAWN T Henry	TITLE HYJG 1 CYLINDER WITH COMPONENTS MOD 2	SCALE 1 / 6
		IDEAL MFG., INC.	DWG NO HYJG-246 M2	REV
		SHEET 1 OF 1		

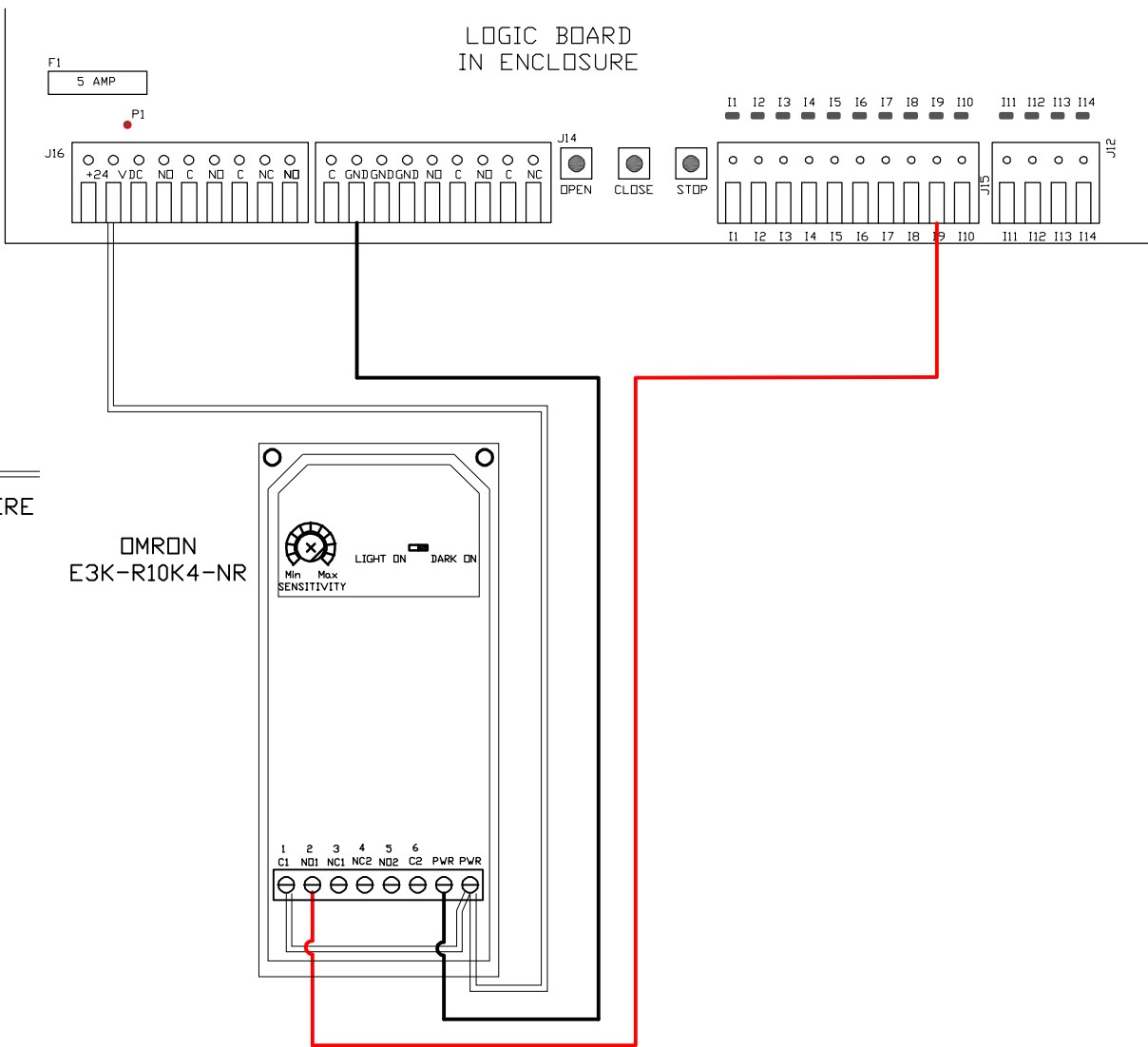

THE RECEIVER N/O CONTACT IS CONNECTED TO TERMINAL I9 ON THE LOGIC BOARD.  
 FOR THE PHOTO EYE TO ACT AS A SAFETY AUXILIARY #1 INPUT FUNCTION ASSIGNMENT WILL BE SET TO  
 "REVERSE OPEN LOOP"  
 PRESS AND HOLD BUTTON SW2 ON THE INTERFACE BOARD UNTIL DISPLAY CHANGES THEN RELEASE THE BUTTON  
 PRESS BUTTON SW4 AND RELEASE UNTIL THE DISPLAY SHOWS  
 "TIMING AND OPTIONS"  
 PRESS AND RELEASE BUTTON SW1 TO ENTER THE MENU THE DISPLAY WILL CHANGE TO  
 "TIMINGS AND OPTIONS"  
 "BASIC SETTINGS"  
 CONTINUE TO PRESS AND RELEASE BUTTON SW4 UNTIL THE DISPLAY SHOWS  
 "TIMINGS AND OPTIONS"  
 "AUXILIARY I / O"  
 PRESS AND RELEASE BUTTON SW1 TO ENTER THE SUBMENU THE DISPLAY WILL SHOW  
 "AUXILIARY # 1 INPUT FUNCTION ASSIGNMENT"  
 PRESS AND RELEASE BUTTON SW1 TO ENTER  
 PRESS AND RELEASE BUTTON SW4 UNTIL THE DISPLAY SHOWS  
 "REVERSE OPEN LOOP"  
 PRESS AND RELEASE BUTTON SW1 TO SAVE  
 PRESS AND RELEASE BUTTON SW2 UNTIL YOU EXIT ALL MENUS  
 THE GATE WILL STOP AND REVERSE WHEN CLOSING TO FULL OPEN AND SET THE AUTO CLOSE TIMER

**TILT-A-WAY HYJG 1  
 REFLECTIVE TYPE PHOTO EYE**

REF NO.	PART NO.	DESCRIPTION	REQ NO
1	PEO434	Photo Eye 24-VDC	1

TILT-A-WAY  
 HYDRAULIC VERTICAL PIVOT GATE  
 HYJG 24 VOLT DC  
 BATTERY LOCATION

PARTS LIST		
ITEM	QTY	DESCRIPTION
1	2	12 VOLT BATTERY
3	1	WEATHER GUARD
2	1	BATTERY SHELF

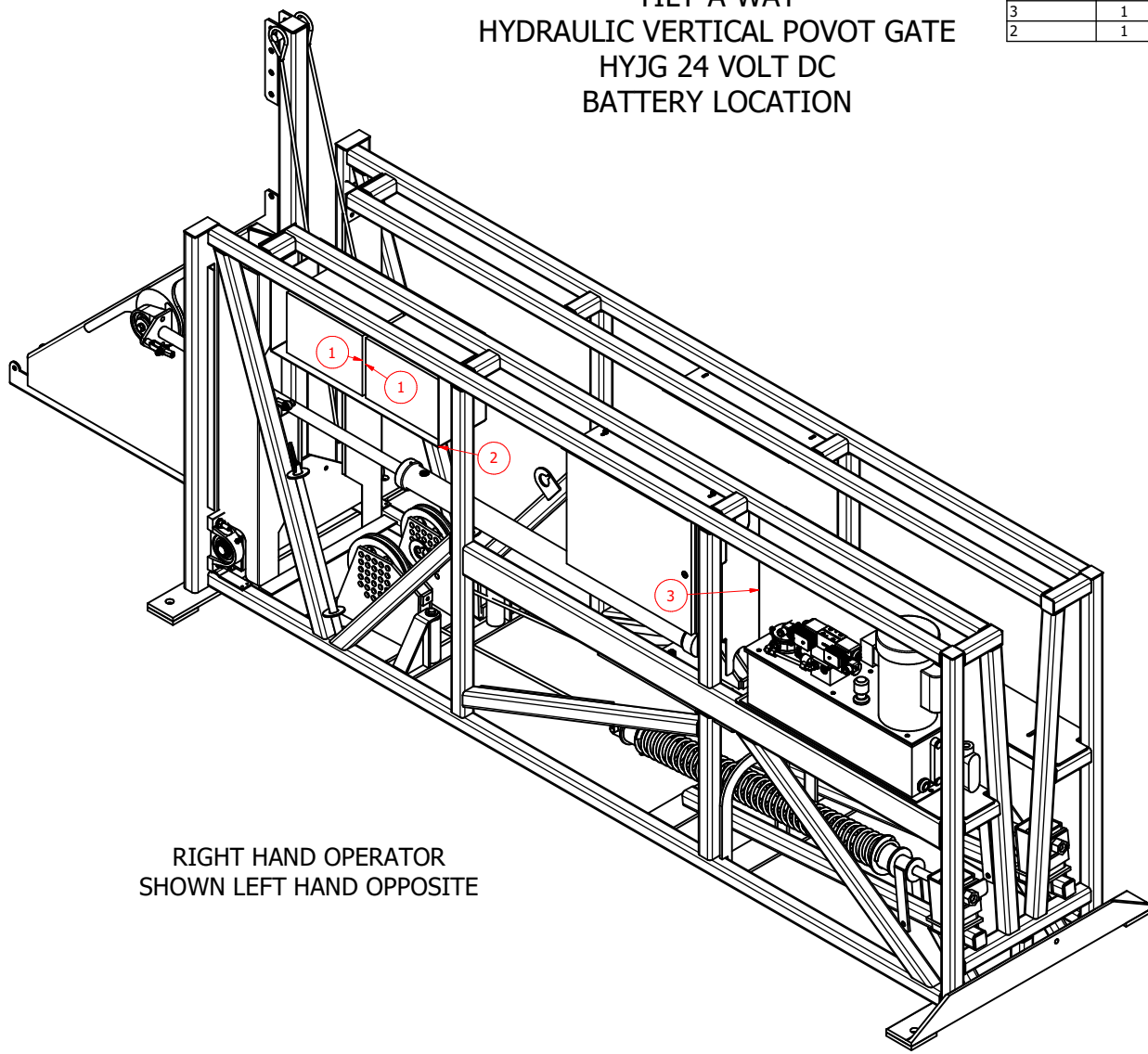

RIGHT HAND OPERATOR  
 SHOWN LEFT HAND OPPOSITE

PROJECTION  
 REMOVE ALL BURRS  
 UNLESS OTHERWISE SPECIFIED  
 DIMENSIONS ARE IN INCHES  
 TOLERANCES ARE:  
 .XX ± .01  
 .XXX ± .005  
 FRACTION 1/2  
 ANGLES 1°  
 DRILLED HOLE 1/4

DRAWN T Henry	9/20/2017
CHECKED	11/5/2019
QA	
MFG	
APPROVED	
MASS 1612.5 lbmass	

**Ideal Mfg., Inc.**  
 2011 Harnish Blvd. Billings MT 59101  
 TITLE  
**HYJG 24 VOLT DC BATTERY LOCATION**  
 SIZE C DWG NO HYJG-256 REV  
 SCALE 0.10 : 1 SHEET 1 OF 1

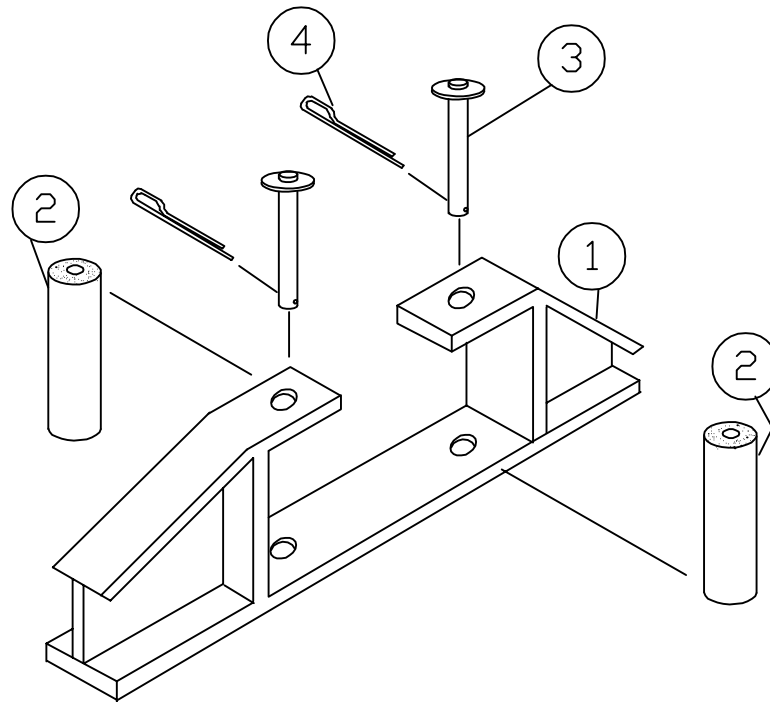

**TILT-A-WAY  
 HYDRAULIC VERTICAL PIVOT GATE  
 HYJG 1  
 BALANCE SYSTEM CABLE GUIDE**

REF. NO.	PART NO.	DESCRIPTION	REQ. NO.
1	FGO707	Support Carriage on Pedestal Frame	
2	FGO127	Plastic Roller	2
3	FGO128	Shaft	2
4	IDI006	3/16" x 1 1/2" Stainless Cotter Pin	2



TILT-A-WAY  
HYJG 1  
HYDRAULIC VERTICAL PIVOT GATE  
BALANCE SYSTEM CABLE AND SHEAVE  
AND OPTIONAL ICE SCRAPERS

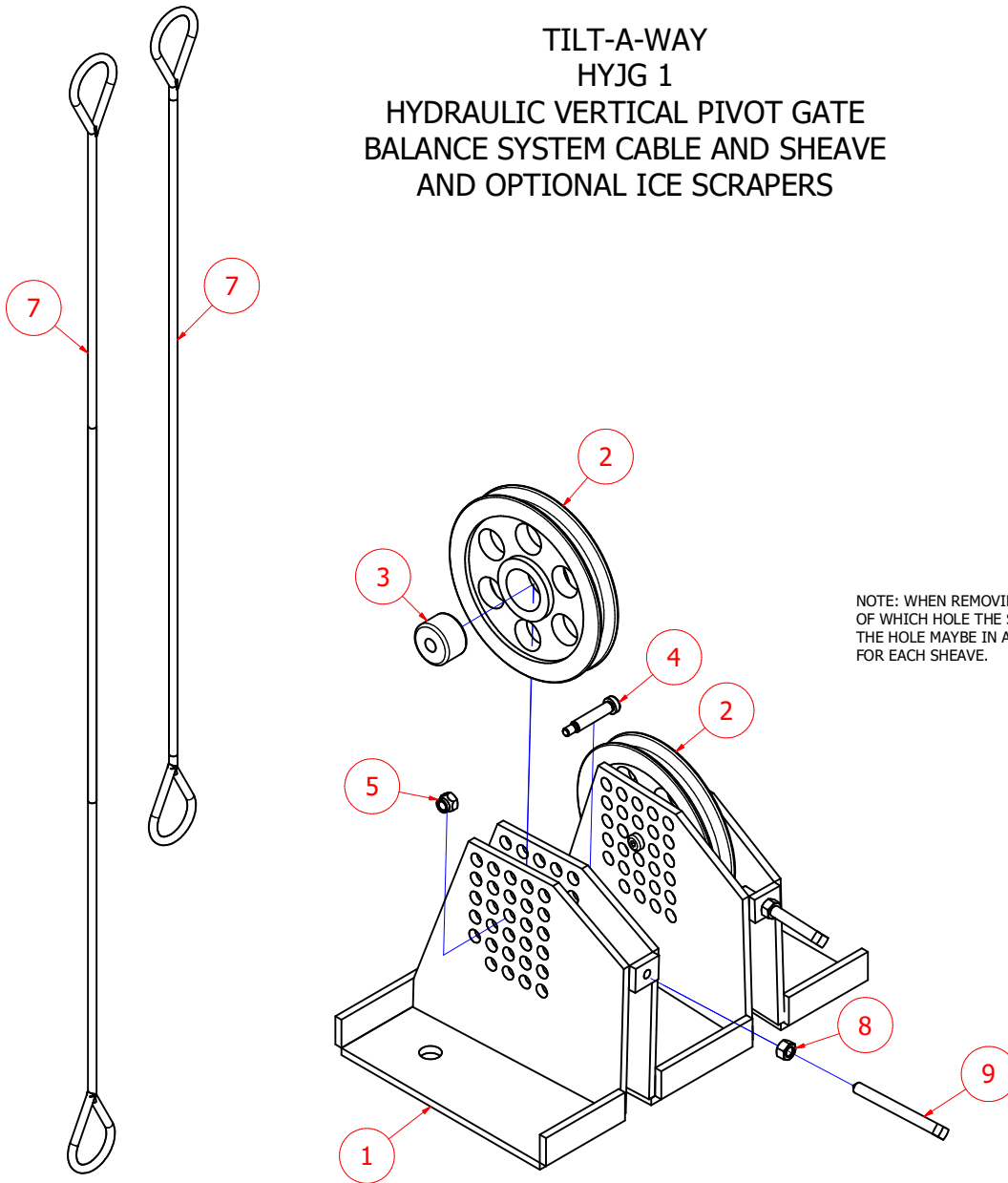

NOTE: WHEN REMOVING SHEAVE MAKE NOTE OF WHICH HOLE THE SHEAVE SHAFT IS IN. THE HOLE MAYBE IN A DEFERENT LOCATION FOR EACH SHEAVE.

PARTS LIST

ITEM	PART NUMBER	DESCRIPTION	QTY
1	FGO708G	SHEAVE MOUNT ON OPERATOR FRAME	1
2	TWO105	CABLE SHEAVE	2
3	TWO106	BEARING (use lock tight when installing new bearing)	2
4	TWO103	SHEAV SHAFT	2
5	N/A	1/2-13 NYLOCK HEX NUT	2
6	TWO110-1	TENSION CABLE 72 1/2"	1
7	TWO110-2	TENSION CABLE 95 1/2"	4
8	N/A	1/2-13 HEX NUT (optional)	2
9	PEO450	ICE SCRAPER BOLT (optional)	2

NOTE: WHEN ORFERING CABLES, MAKE SURE YOU HAVE THE SERIAL NUMBER OF YOUR GATE. THIS WILL INSURE THAT THE RIGHT SIZE CABLES ARE SHIPPID TO YOU.

DRAWN T Henry	12/9/2015	<b>Ideal Mfg., Inc.</b> 2011 Harnish Blvd. Billings MT 59101 Tel. (406) 656-4360	
CHECKED	3/25/2016		
QA		TITLE HYJG BALANCE SYSTEM AND SHEAVE	
MFG		SIZE C	DWG NO HYJG-249
APPROVED		SCALE	REV
		SHEET 1 OF 1	

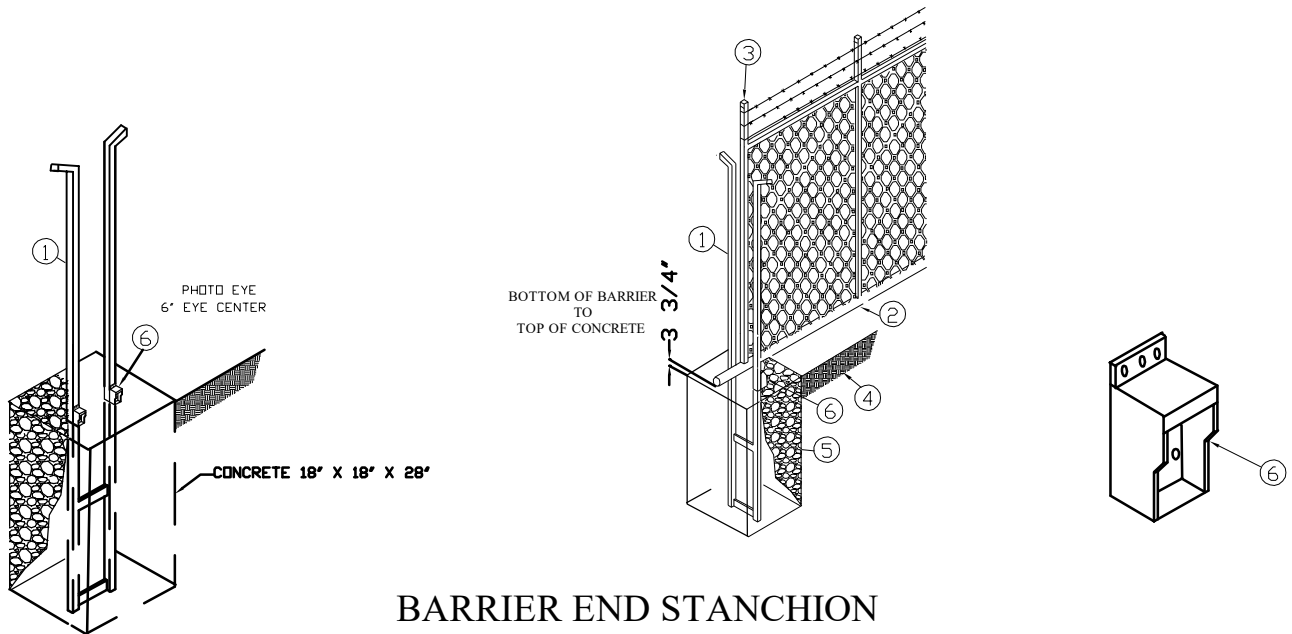

### BARRIER END STANCHION

REF NO.	PART NO.	DESCRIPTION	REQ NO
1	FGO172	Stanchion Unit	1
2	N/A	Barrier Main Tube 3 3/4" Clearance to grade-line	
3	N/A	Barrier Post flush with stanchion.	
4	N/A	Grade Line	
5	N/A	Concrete Embedment Block top at grade line or below size to suit conditions	
6	PEO454	Photo Eye	2

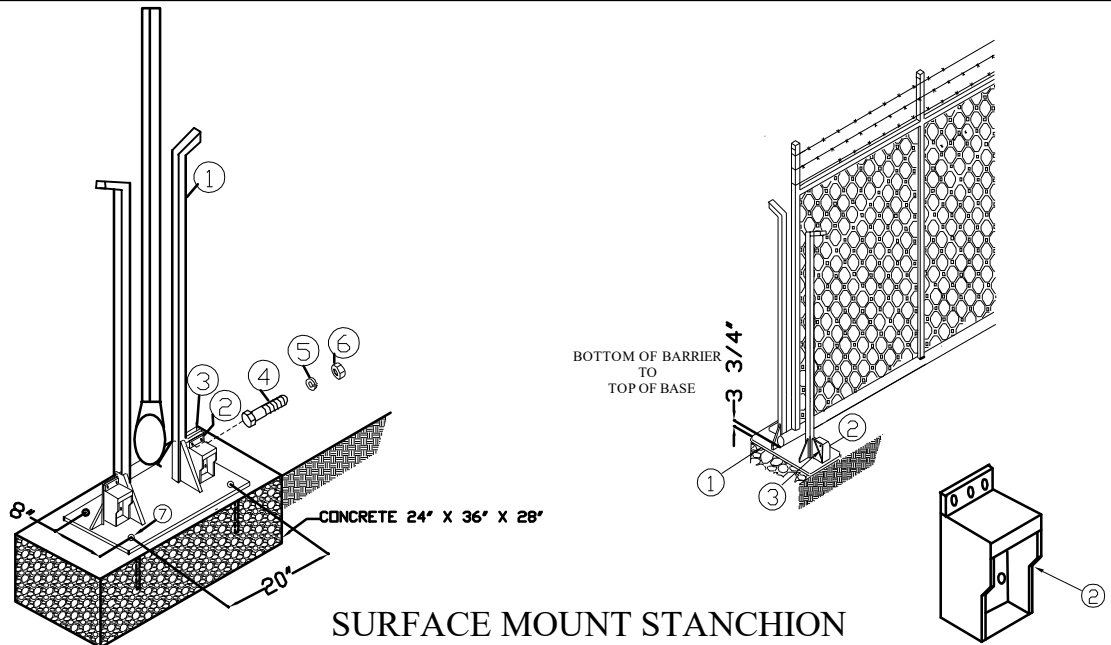

### SURFACE MOUNT STANCHION

REF NO.	PART NO.	DESCRIPTION	REQ NO
1	FGO407	Surface Mount Stanchion Unit	1
2	PEO454	Photo Eye ( 2 on operator)	2
3	FGO406	Photo Eye Mount	2
4	N/A	5/16" x 1" Bolt	4
5	N/A	5/16" Lock Washer	4
6	N/A	5/16" Hex Nut	4
7	NA	3/4" x 6" Exposed Bolts	4

4

3

2

1

Parts List

ITEM	PART NUMBER	QTY	DESCRIPTION
1	N/A	1	GATE
2	PEO277-1	1	MAGNET ASSEMBLY
3	N/A	4	10-32 X 1 MACHINE SCREW
4	N/A	1	ANTI-SPIN BRACKET
5	PEO277-1	1	ARMATURE
6	N/A	2	8-32 X 3/8 MACHINE SCREW
7	N/A	1	Hexagon Socket Head Cap Screw 5/16-24 X 2
8	N/A	1	ARMATURE SPACER
9	N/A	1	SEX NUT
10	POO194	1	SPRING
11	PEO279-1	1	CONDUIT COUPLER
12	PEO279	2	1/2 STEEL STRIAN RELEAF
13	N/A	4	PLUG BUTTON
14	N/A	1	STANCHION
15	FGO277-R FGO277-L	1	ARMATURE MOUNT RIGHT HAND GATE ARMATURE MOUNT LEFT HAND GATE
16	N/A	2	1/2-13 X 3 Hex Bolt
17	N/A	2	1/2 FLAT WASHER
18	N/A	2	1/2 LOCK WASHER
19	N/A	2	1/2-13 Hex Nut

YOKE

1

2

13

3

5

6

7

10

9

4

6

11

12

1

12

1

12

12

11

2

3

7

5

8

17

16

6

8

4

19

18

14

FREE END OF GATE BARRIER  
THIS SIDE OF STANCHION

DRAWN THenry	5/20/2011	<b>IDEAL MFG., INC.</b> 2011 Hamish Blvd. Billings MT 59101 Tel. (406) 656-4360	
CHECKED	7/25/2014		
QA		TITLE	
MFG		HYJG MAGLOCK MOUNTING	
APPROVED		SIZE	DWG NO
		C	HYJD-B 317
		SCALE	SHEET 1 OF 1

**TILT-A-WAY  
HYDRAULIC VERTICAL PIVOT GATE  
BALANCE SYSTEM SPRING TENSIONER UNIT  
DRAWING HYJG-251  
(2 ASSEMBLIES INCLUDED)**

<b>REF NO.</b>	<b>PART NO.</b>	<b>DESCRIPTION</b>	<b>REQ'D NO.</b>
1	N/A	Operator Frame	
2	FGO761	Safety Device Brackets	2
3		Tension Spring	
	TWO137	500 Pound Blue	As required
	TWO138	1000 Pound Yellow	As required
	TWO139	1500 Pound Orange	As required
	TWO112	1750 Pound Green	As required
	TWO140	2000 Pound Red	As required
	TWO113	2500 Pound White	As required
4		Front Spring Connector	
	FGO168	500 or 1000 Pound Spring	2
	FGO170	1500 or 1750 Pound Spring	2
	FGO171	2000 or 2500 Pound Spring	2
5	TWO104	Clevis Pin	2
6		Rear Spring Connector	
	FGO139	500 or 1000 Pound Spring	2
	FGO157	1500 or 1750 Pound Spring	2
	FGO159	2000 or 2500 Pound Spring	2
8	FGO130	Tension Screw with End Nut Welded	2
9	TWO133	Safety Compression Spring	2
10	FGO131	Safety Nut	2
11	TWO108	Set Screw	2
12	N/A	½" x 3" Hex Head Bolt	2
13	N/A	½" Lock Nut	2
14	N/A	1" SAE Washer	4
15	FGO174	Pipe Spacer	2
16	ID1061	Cotter Pin	2
17	PEO613	Safety Switch	2
18	FGO161	Safety Release Bar	2

TILT-A-WAY  
HYDRAULIC VERTICAL PIVOT GATE  
HYJG 1  
BALANCE SYSTEM SPRING  
TENSIONER UNIT

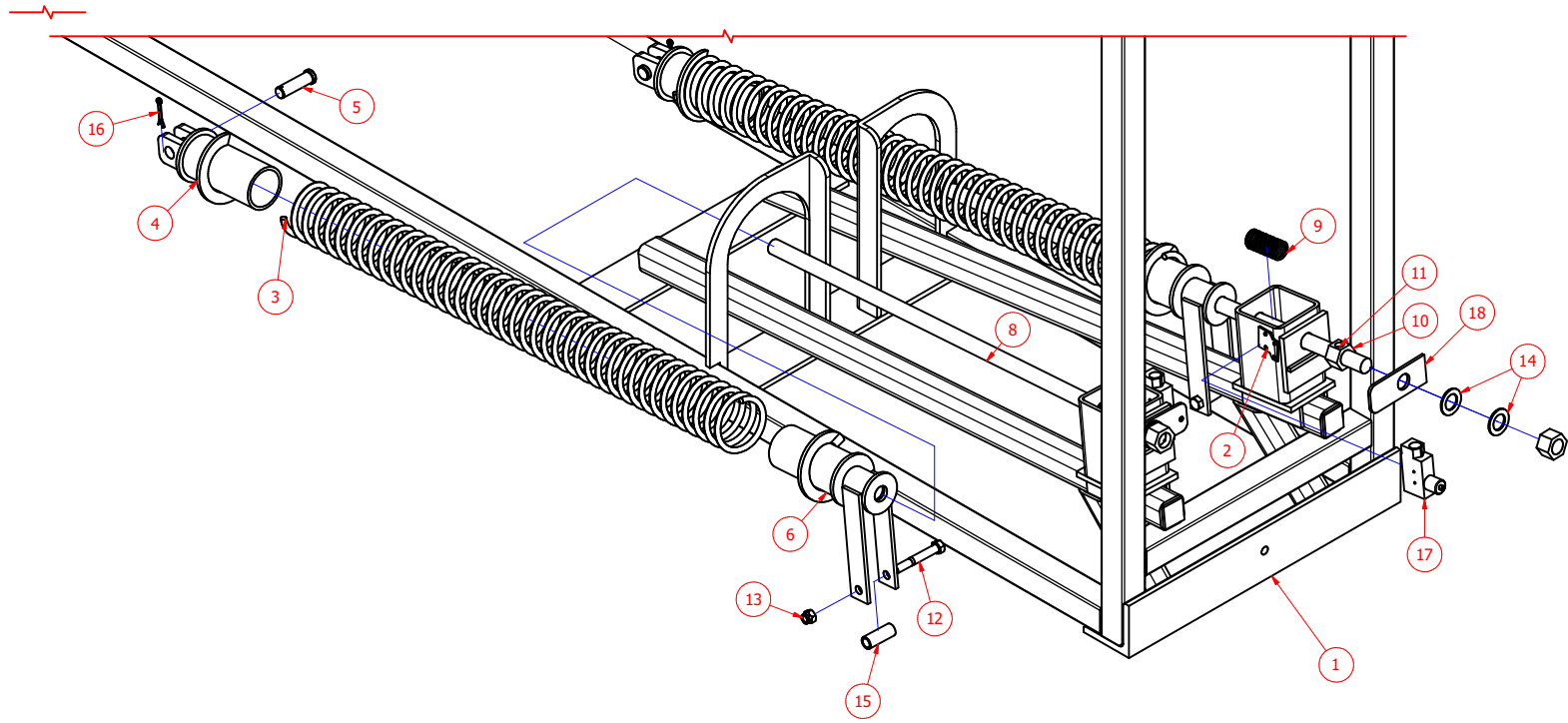

DRAWN	THenry	7/24/2014	<b>IDEAL MFG., INC.</b> 2011 Harnish Blvd. Billings MT 59101 Tel. (406) 656-4360	
CHECKED		3/25/2016		
QA			TITLE <b>HYJG BALANCE SYSTEM SPRING TENSIONER UNIT</b>	
MFG			SIZE <b>C</b>	DWG NO <b>HYJG-251</b>
APPROVED			SCALE	REV
			SHEET 1 OF 1	

**TILT-A-WAY  
HYDRAULIC VERTICAL PIVOT GATE  
HYJG 1 HYDRAULIC SYSTEM**

**DRAWING HYJG-252**

<b>REF NO.</b>	<b>PART NO.</b>	<b>DESCRIPTION</b>	<b>REQ'D NO.</b>
1	TWO575-1	Hydraulic Cylinder	1
2	100125 100126 100135	Hydraulic Pump & Reservoir Set Single Phase Hydraulic Pump & Reservoir Set 24 VDC Hydraulic Pump & Reservoir Set Three Phase	1
3	TWO528	#6 MORB X #6 MJIC Adapter	2
4	TWO402	Short 3/8 Pressure Hose 36"	1
5	TWO164	Long 3/8" Pressure Hose 87"	1
6	TWO579	90 degree Elbow	1
7	TWO578	90 degree Elbow (long)	1
8	TWO520 TWO462	In Tank Heater AC Unit In Tank Heater DC Unit	1
9	TWO524	Pressure Relief Valve (factory set at 385 psi)	1
10		Manual Override Valves	2
11	100123	Cylinder slow down driver open	1
12	100123	Cylinder slow down driver closed	1
13		Sight Gauge	1
14	100121	Proportional Valves	1

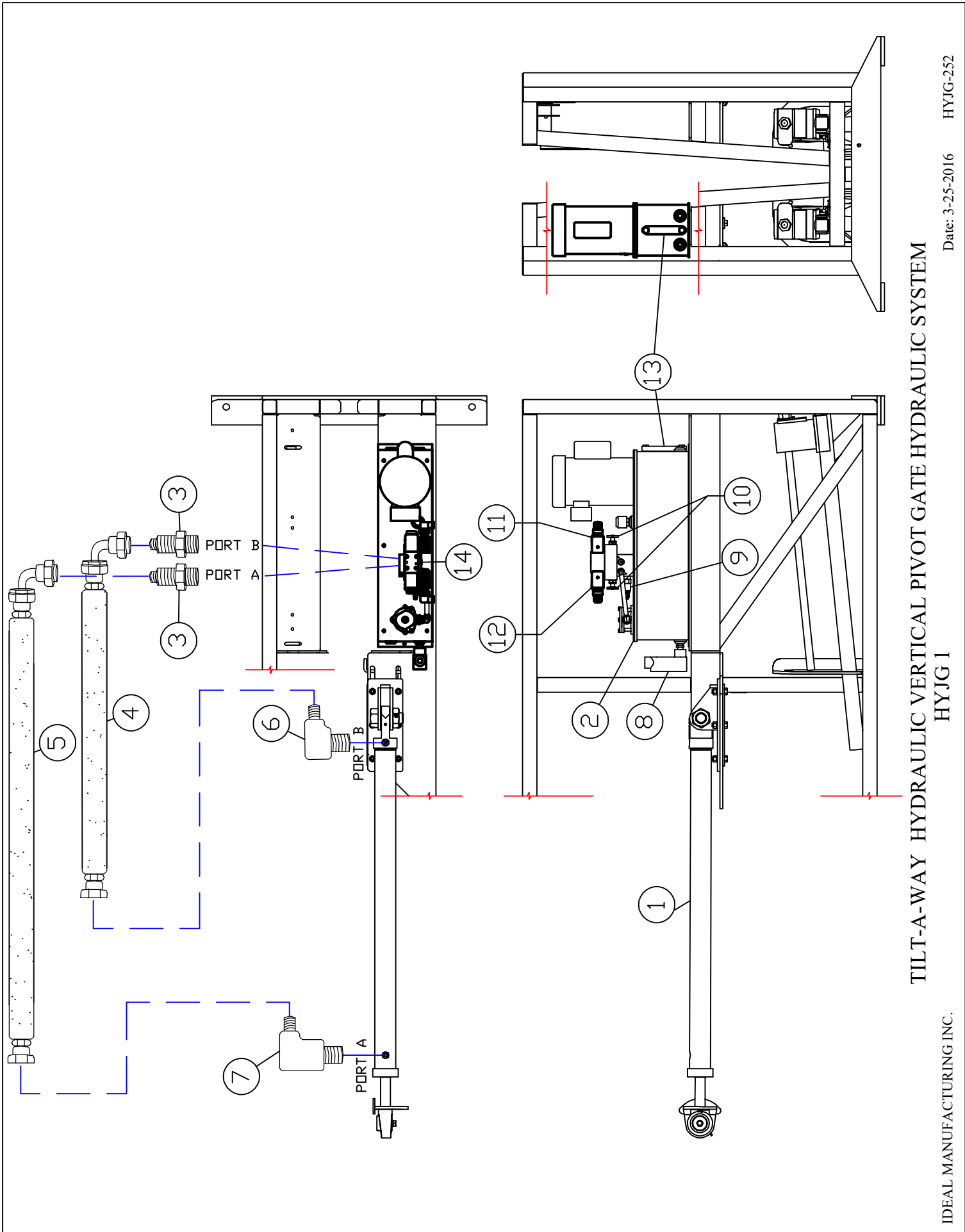

**TILT-A-WAY  
HYDRAULIC VERTICAL PIVOT GATE  
HYJG 1 HYDRAULIC UNIT**

REF NO.	PART NO.	DESCRIPTION	QTY
1	100125A 100137 100136A	1 HP, 110/220 VAC 1PH, TEFC, MOTOR 1 HP, 24 VDC, TEFC, MOTOR 1 HP, 240/480 VAC 3 PH, TEFC, MOTOR	1
2	100145	3/8" TUBING RETURN	1
3	TWO512	GEAR PUMP	1
4	TWO513	IN TANK FILTER HOUSING	1
5	TWO514	7 MICRON NOMINAL CELLULOSE FILTER	1
6	100139	MANIFOLD	1
7	100121	DIRECTIONAL VALVE	1
8	100142	CUSTOM RESERVOIR	1
9	100143	SIGHT GLASS	1
10	TWO519	BREATHER FILLER CAP	1
11	TWO520 TWO462	240 VAC 1PH HEATER W/ THERMOSTAT 120 VAC HEATER W/ THERMOSTAT DC UNIT	1
12	TWO523	BY PASS VALVE	2
13	TWO522	PRESSURE RELIEF VALVE	1
14	TWO526	#12 MORB X #16 HOSE BARB ADAPTER	1
15	TWO528	#6 MORB X #6 MJIC ADAPTER	3
16	TWO529	#8 MORB X #6 MJIC 90 DEG. ADAPTER	1
17	TWO530	#10 MORB X #6 MJIC 90 DEG. ADAPTER	1
18	100144	3/8" TUBING PRESSURE	1
19	N/A	10-24 X 3 SOCKET HEAD CAP SCREW	4
20	N/A	1/4-20 X 1/2 FLANGE BOLT	3
21	N/A	1/4-20 X 1 SOCKET HEAD CAP SCREW	2
22	N/A	1/4-20 NYLOCK HEX NUT	2
23	N/A	3/8 LOCK WASHER	12
24	N/A	3/8-16 X 1 HEX BOLT	10
25	N/A	3/8-16 X 1 1/4 HEX BOLT	2
26	N/A	5/16 LOCK WASHER	4
27	N/A	5/16 X 3/4 HEX BOLT	4
28	100138	BYPASS VALVE BODY	1
29	100123	VALVE DRIVER	2
30	TWO579	#6 MORB X #6 MJIC 90 DEG. ADAPTER	1
31	100140	GASKET	1
32			



FACTORY SET AT  
385 PSI DO NOT  
EXCEED THIS SETTING

TILT-A-WAY  
HYDRAULIC VERTICAL PIVOT GATE  
HYJG 1 HYDRAULIC UNIT

DRAWN	12/15/2015	Ideal Mfg., Inc. 2011 Harnish Blvd. Billings MT 59101 Tel. (406) 656-4360		
CHECKED	3/25/2016			
QA		TITLE		
MFG		HYJG 1 HYDRAULIC UNIT		
APPROVED		SIZE	DWG NO	REV
		C	HYJG-256	
		SCALE	SHEET 1 OF 1	

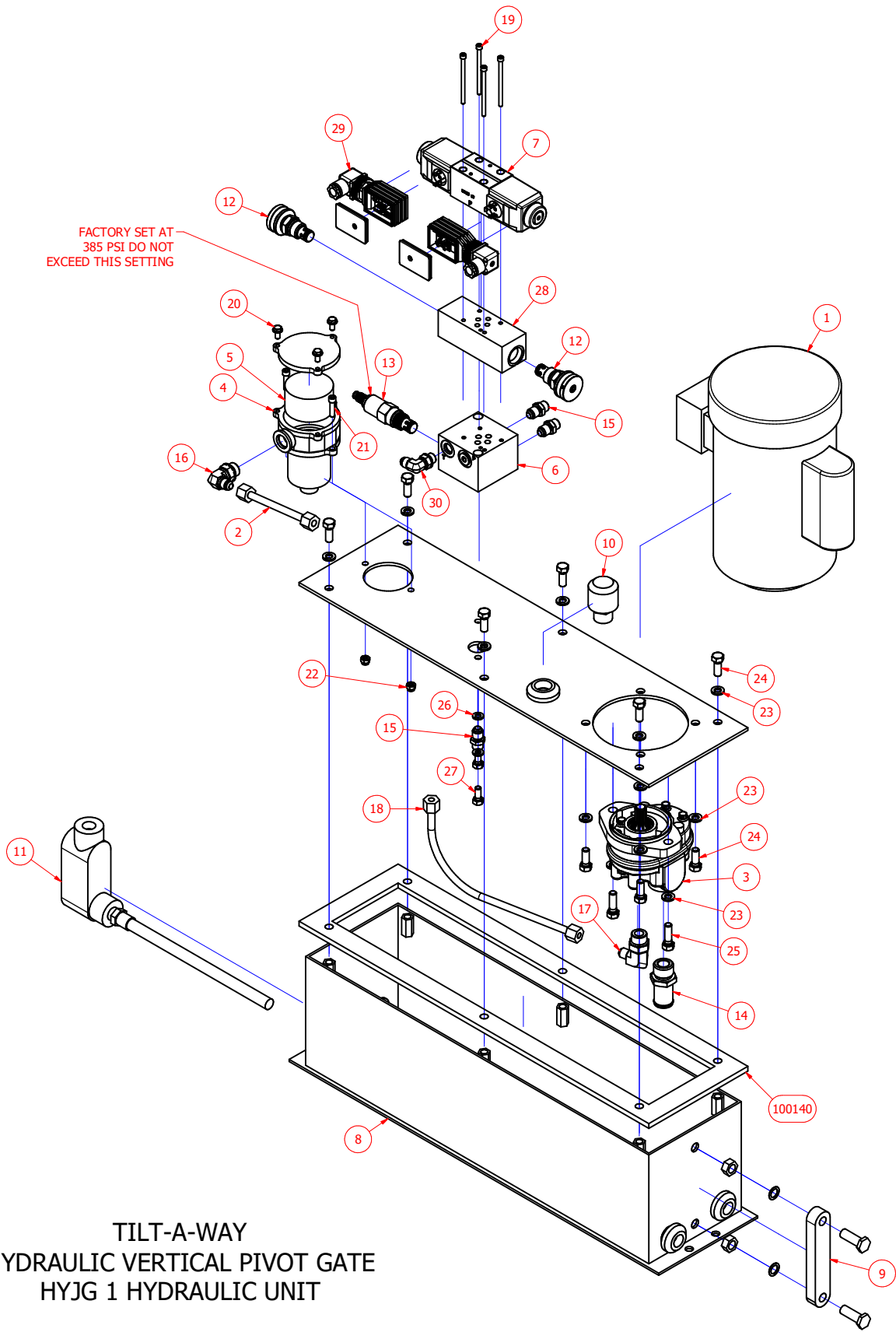

## Tilt-A-Way HYJG Trouble Shooting Guide

When calling Ideal Mfg., Inc. for trouble shooting help please note which lights on all of the boards are on.

The following lights are normally on.

**Logic Board.**

Light P1 (red power light).

Light CAN1 (green communication to Motor Board, red communication lost to Motor Board)

Light I3 (red stop circuit normally closed).

**Motor Board.**

Light DS2 (green power light).

<b>PROBLEM</b>	<b>DISPLAY</b>	<b>LIGHTS ON</b>	<b>SOLUTION</b>
Gate closed and will not open	Blank	None	Power lost. Breaker turned off. Check battery connections and incoming ac power. Broken spring or cable safety switch open.
Gate closed and will not open	Full Closed	P1 CAN1	Stop circuit open. Check all external stop push buttons.
Gate closed and will not open	Full Closed	P1 CAN1 I3 I12	Opening safety edge active or shorted. Check for obstruction or replace if shorted.
Gate closed and will not open	Full Closed Schedule Lockout	P1 CAN1 I3	Lockout Schedule active, Turn lockout schedule off in menu.
Gate closed and will not open	Full Closed Low Voltage Secure	P1 CAN1 I3	Battery voltage is low. Check battery charge for proper operation and battery connections.
Gate closed and will not open	Full Closed Scheduled auto-open	P1 CAN1 I3	Check Lockout schedule for over lapping times with Auto-open schedule.
Gate closed and will not open	Full Closed Service Lockout	P1 CAN1 I3	Service lockout for all maintenance has been disabled. In menu Service change to Controller Enabled.
Gate opened and will not close	Blank	None	Power lost. Breaker turned off. Check battery connections and incoming ac power. Broken spring or cable safety switch open.
Gate opened and will not close	Full Open	P1 CAN1	Stop circuit open. Check all external stop push buttons.
Gate opened and will not close	Full Open	P1 CAN1 I3 I11	Closing safety edge active or shorted. Check for obstruction or replace if shorted.

## Trouble Shooting Guide

<b>PROBLEM</b>	<b>DISPLAY</b>	<b>LIGHTS ON</b>	<b>SOLUTION</b>
Gate opened and will not close	Full Open Pending Auto Close	P1 CAN1 I3 I5	Aux timer is active. Clear input to I5 Aux timer.
Gate opened and will not close	Full Open Pending Auto Close	P1 CAN1 I3 I6	Timer hold is active. Clear input to I6 Timer hold.
Gate opened and will not close	Full Open Pending Auto Close	P1 CAN1 I3 I7	Timer set is active. Clear input to I7 Timer set
Gate opened and will not close	Full Open Pending Auto Close	P1 CAN1 I3 I8	Reveres open loop is active. Clear input to I8 Reveres open loop.
Gate opened and will not close	Full Open Pending Auto Close	P1 CAN1 I3 I9	Aux # 1 input is active. Clear input to I9 Aux # 1 input.
Gate opened and will not close	Full Open Pending Auto Close	P1 CAN1 I3 I10	Aux # 2 input is active. Clear input to I10 Aux # 2 input.
Gate opened and will not close	Full Open Schedule Auto-Open	P1 CAN1 I3	Auto-Open Schedule active. Turn Auto-Open Schedule off in menu.
Gate opened and will not close	Full Open Low Voltage Failsafe	P1 CAN1 I3	Battery voltage is low. Check battery charge for proper operation and battery connections.
Gate in any position and will not move		CAN1	Fuse F1 5 amp blown on Logic Board. Replace with same type and rating.

## Trouble Shooting Guide

PROBLEM	DISPLAY	LIGHTS ON	SOLUTION
Gate stopped mid-travel	Stopped mid-travel Entrapment stop Obstruction detected UL reset to clear	P1 CAN1 (red) A1 (red) I3	UL Entrapment activated. Check for obstructions in operator and around barrier. Push red UL rest button. Check inherent settings.
Gate stops and reverses and stops during closing cycle	Stopped mid-travel	P1 CAN1 I3	Position Feedback Potentiometer has failed, loose wire connections, or improper wire connections.
Gate stops and reverses and stops during opening cycle	Stopped mid-travel	P1 CAN1 I3	Position Feedback Potentiometer has failed, loose wire connections, or improper wire connections.
Gate runs slow in both open and close cycle.	Bad Position Pot		Check potentiometer, turns with drive sprocket, loose or broken wire.

## INFORMATIONS IMPORTANTES SUR LA SÉCURITÉ

**Avant d'installer le programme d'installation doit lire et comprendre les instructions du manuel et de sécurité du propriétaire. Le propriétaire doit lire et conserver ce manuel du propriétaire. Lire et suivre toutes les instructions.**  
**AVERTISSEMENT-POUR RÉDUIRE LE RISQUE DE BLESSURES OU LA MORT AUX PERSONNES**

1. Ne pas faire fonctionner la porte à moins que tous les dispositifs de sécurité sont connectés et fonctionnent correctement.
2. Ne pas permettre aux enfants de jouer sur ou autour d'une porte. Gardez tous les contrôles hors de portée des enfants.
3. portes automatiques ne sont pas destinés à un usage piéton. Les piétons doivent être fournis une entrée séparée distincte de la porte automatique.
4. Ne jamais faire fonctionner un système de porte automatique sans contact visuel afin qu'il puisse être arrêté si nécessaire.
5. Les contrôles d'accès, sont nécessaires, à monter au moins 6 pieds de la porte et l'opérateur.
6. Coupez l'alimentation avant d'effectuer toute opération de maintenance sur votre portail ou de l'opérateur.
7. Gardez votre porte bien entretenus-ont une personne qualifiée faire toutes les réparations.
8. Un technicien qualifié doit tester votre porte mensuelle. La porte DOIT remonter au contact avec un objet rigide ou d'arrêt quand un objet active un capteur sans contact. Après réglage de la force de la limite de Voyage, retester l'opérateur de porte. Ne pas ajuster et tester à nouveau l'opérateur de porte correctement peut augmenter le risque de blessure ou de décès.
9. La porte et l'opérateur doivent avoir deux dispositifs de sécurité appropriés pour correspondre à l'installation de la classe de porte.
10. Opérateur et la barrière doivent afficher des panneaux d'avertissement sur les deux côtés, en vue de l'opérateur.
11. Ne pas installer le poids supplémentaire à la barrière de la porte, votre barrière a été équilibré à l'usine, si vous ajoutez du poids à la porte barrière il fera de votre porte hors de l'équilibre, ce qui pourrait entraîner un dysfonctionnement.
12. Seul le personnel qualifié doit installer cet équipement. Le non-respect de cette exigence pourrait causer des blessures graves et ou la mort, pour lesquels le fabricant ne peut pas être tenu responsable.
13. Dispositifs de sécurité, tels que les yeux de photo et les bords d'inversion doivent être installés pour assurer la protection personnelle la propriété et les piétons.
14. Avant la mise sous tension Assurez-vous que la tension correcte a été fournie au moteur électrique et l'équipement a été correctement mise à la terre.
15. Gardez toujours les gens et les objets loin de la porte. PERSONNE NE DOIT TRAVERSER LE PARCOURS DE LA PORTE EN MOUVEMENT.

### CLASSE DE GATES VEHICULES - Glossaire

#### CLASS I-RÉSIDENTIEL OPÉRATEUR GATE VÉHICULAIRE (3.19)

Un opérateur de porte de véhicule (ou système) destinés à être utilisés dans des garages ou des aires de stationnement associés à une résidence de un à quatre familles monoparentales.

#### CLASSE II-COMMERCIAL / GENERAL accès véhiculaire PORTAIL (3.4)

Un opérateur de véhicule de grille (ou système) destiné à être utilisé dans un emplacement commercial ou la construction tels que l'unité multi-logements collectifs (cinq ou plus unité familiale), hôtel, garages, magasins de détail, ou d'autres bâtiments accessibles par le service de la population en général .

#### CLASSE III-INDUSTRIEL / LIMITED ACCESS VÉHICULAIRE PORTAIL (3.11)

Un opérateur de porte de véhicule (ou système) destinés à être utilisés dans un emplacement industriel ou la construction comme une zone de l'usine ou le quai de chargement ou d'autres endroits non accessibles par ou destinés à desservir le grand public.

#### CLASSE IV-RESTRICTED ACCESS VÉHICULAIRE OPERATEUR GATE (3.20)

Un opérateur de véhicule de grille (ou système) destiné à être utilisé dans un emplacement industriel surveillé ou la construction, comme une zone de sécurité de l'aéroport ou autre lieux d'accès restreint pas l'entretien du grand public, dans lequel l'accès non autorisé est empêché par l'intermédiaire d'une surveillance par un personnel de sécurité.

### INSTRUCTIONS POUR MODE D'EMPLOI TILT-A-WAY MODÈLE HYJG

**Remarque: Utilisez la commande manuelle uniquement lorsque la porte ne se déplace pas et avec le pouvoir désactivé**

1. Repérez deux boutons moletés en laiton de couleur sur le dessus du boîtier de la pompe
2. (Si équipé d'un paquet de temps froid, lift flap sur le couvercle noir pour accéder aux boutons.)
3. Tournez les deux boutons dans le sens antihoraire un tour complet pour ouvrir.
4. Porte barrière peut maintenant être soulevée manuellement à partir à la fin de la porte.
5. Tournez les boutons dans le sens horaire pour fermer, puis utiliser la porte normalement.

### PROTECTION CONTRE LE PIÉGEAGE

Porte catégorie d'opérateurs	
glissière horizontale, ascenseur vertical. et le pivot vertical	Swing et barrière verticale (bras)
types de protection de Entrapment (A)	types de protection de Entrapment (A)
A, B1, B2, ou D	A, B1, B2, C, ou D
Notez-Le même type de dispositif ne doit pas être utilisé pour les deux moyens de protection piégeage. L'utilisation d'un seul appareil à la fois le sens d'ouverture et de fermeture est conforme à l'exigence; cependant, un seul appareil ne soit pas nécessaire pour couvrir les deux directions. Une combinaison d'un type B1 pour une direction et un de type B2 pour l'autre sens est l'équivalent d'un dispositif dans le but de se conformer aux exigences des moyens de protection soit piégeage. (A) les types de protection de Piégeage: Type A - Inhérente système de protection de la provocation policière. Voir 31.1.5.Type B1 –Non-contact sensor (photoelectric sensor or the equivalent). See 31.1.6 - 31.1.9. Tapez capteur B2 -Contactez (dispositif de bord ou l'équivalent). Voir 31.1.7 et 31.1.11 - 31.01.13. Type C - la force intrinsèque de limitation, d'embrayage réglables intrinsèque ou inhérente dispositif de décharge de pression. Voir 31/01/15 et 31.2.1.2 (b). Tapez dispositif D -Actuating exigeant une pression continue à maintenir l'ouverture ou le mouvement de fermeture de la porte. Voir 31/01/16 et 31/01/17.	

# Tilt-A-Way HYJG 1

## INFORMATIONS GÉNÉRALES

Tilt-a-way HYJG porte pivot vertical fonctionne sur différentes tensions. Ils sont 240-vac monophasé, 240-vac triphasé, 480-vac triphasé, ou 24 Vcc. Si la porte fonctionne sur 24 Vdc bien besoin de deux batteries de 12 Vdc (piles non comprises). Nous recommandons deux entretien de l'acide sans plomb 12 volts série de cycle profond 27 batterie 85 ampères-heures ou équivalent. Les deux batteries de 12 volts sont câblés en série pour fournir 24 volts aux tableaux de commande. Le faisceau de câblage est équipé de bornes d'anneau destiné à se connecter à la batterie post type boulon (fil rouge à fil positif et noir au négatif). Voir le schéma de câblage à la page 9 de ce manuel. Ne pas inverser la polarité des piles à la carte de la batterie ou circuit. De graves dommages se produira. Débranchez la batterie et toutes les sources d'alimentation avant d'installer tous les périphériques. Ne pas effectuer le soudage alors que le câble moteur est connecté à la carte de contrôle ou la batterie connectée. graves dommages à la carte de commande et la batterie se produira.

Attention - Risque d'explosion si la batterie est remplacée par un type incorrect.

Jetez les piles usagées conformément aux instructions du fabricant des batteries.

Tilt-a-way HYJG porte pivot vertical a un tableau de commande programmable, ce qui permet de nombreuses fonctions programmables dans diverses combinaisons (voir la section de programmation à ce manuel). Le panneau de commande a Position Feedback. Si la porte change de direction deux fois et arrête en raison de la rétroaction de position du tableau de commande devra être UL réinitialisé.

Un chargeur de batterie est fourni pour garder les batteries chargées sur le modèle 24 Vcc. Voir le manuel du chargeur propriétaire pour un bon fonctionnement.

Un technicien qualifié doit vérifier et régler tous les dispositifs de sécurité mensuelle. Le solde de la barrière doit également être vérifié et ajusté mensuellement par un technicien qualifié.

# Détecteur de boucle de véhicule



CE

# Mode d'emploi

---

## PRÉCAUTIONS ET AVERTISSEMENTS

---



*CEXIGENCES de la CE: Utiliser boucles pré-formé EMX avec suppression des surtensions intégrée pour conformité CE. À la terre, raccorder le blindage du câble en fil.*

*EXIGENCES de la CE: Utilisez CE coté alimentation pour conformité CE fournissant la répression comme spécifié par EN61000-4-5.*

*Ne doit pas être utilisé dans des applications de sécurité*

*Lorsque plus d'un détecteur de boucle est utilisé, valeur chacun d'eux à une fréquence différente.*

*Référez-vous au diagramme de DIP-switch pour les paramètres de fréquence.*

### IMPORTANT :

Ce produit est un accessoire ou une partie d'un système. Toujours lire et suivre les instructions du fabricant de l'équipement avant de connecter ce produit. Se conformer aux codes et normes de sécurité. Faute de quoi peut entraîner des dommages, blessures ou la mort.

---

## PRÉSENTATION DU PRODUIT

---

Détecteur de boucle ULT-PLG le véhicule est compatible avec la plupart des opérateurs de porte. L'ULT-PLG peut être utilisé dans le centre, en sécurité et sortie bouclent postes. Fonction d'affichage du The UltraMETER™, installation facile en affichant le réglage optimal requis pour détecter un véhicule étant placé sur la boucle. Dix réglages de sensibilité permettent un réglage fin du niveau de détection. Le fonctionnalité détecter sur Stop (DOS®) permet de détecter uniquement lorsqu'un véhicule est venu à un arrêt complet. Sortie B interrupteur permet la configuration de la sortie 2 pour FAIL, PULSE ON entrée, sortie ON PULSE ou même AS OUPUT A. Quatre réglages de fréquence une flexibilité dans la prévention de diaphonie dans les boucles multiples applications.

L'ULT-PLG est compatible avec une grande variété d'opérateurs de porte notamment :

- Advanced Access automatisation/FAAC CSL2000, CSW2000, RSW1000
- All-O-Matic SL100-DC
- Apollon 4300, 4500
- Chamberlain/Elite SL3000, CSW200
- IntelliGate systèmes IQ500, IQ5000
- Linéaire (OSCO) avec le contrôleur de l'APeX
- PowerMaster opérateurs avec les contrôleurs PowerMaster
- Les systèmes hilaires rotatif modèles SL1000C, SL1000I, SL1000R
- SECOM tard modèle opérateurs avec 10 connecteurs Molex
- TYM TyMetal 1000, TYM 2000
- Accès Viking modèles L-3, F-1, T-21, H-10, B-12, Q-4



## Spécifications

Sensibilité	10 niveaux, 0-9
UltraMETER™ Affichage	Indique le niveau de sensibilité optimale, 0-9 Aide au diagnostic
Boucle fréquence	4 réglages (low, med-low, med-Salut, élevé)
Boucle inductance	20... 2000µH (facteur Q > 5)
Boucle de mise à la terre	Transformateur d'isolation permet un fonctionnement avec des boucles de mauvaise qualité
Syntonisation automatique	Détecteur de tunes à boucle sur la mise sous tension et en suivant la fonction count de fréquence
Suivi environnemental	Compensation automatique
Protection contre les surtensions	Boucle des circuits protégés par des supresseurs de surtension
Détecter la sortie	État solide
Sortie B	État solide
B sortie inversée	État solide
Alimentation / boucle voyant de défaillance	LED verte
Détecter / fréquence count indicateur	LED rouge
ASB (sensibilité automatique Boost)	Augmente la sensibilité après la détection initiale afin d'éviter l'abandon en raison de la haute-lit véhicules
Puissance	12VDC... 24VDC (voir mises en garde et avertissements)
D'exploitation courant	15 mA
Température de fonctionnement	-40 ° C... 82°C (-40°F... 180°F) 0... 95 % d'humidité relative
Dimensions (L x l x H)	3.0"(76mm) x 0.9"(22mm) x 2.75"(70mm)
Poids	0.15 lbs. (68 g)
Connecteur	10 broches femelle



---

# OPÉRATION

---

## Mise sous tension

À mettre sous tension l'initialise de détecteur en ajustant automatiquement à la boucle. La LED verte indique que le détecteur est alimenté et opérationnel.

## Réglage de la fréquence

La fréquence de fonctionnement de la boucle est fonction de l'inductance de boucle spécifique et les réglages du commutateur DIP 1 et 2. L'objectif principal de la réglage de la fréquence est de permettre à l'installateur la possibilité de définir différentes fréquences pour les installations de boucles multiples, recommandée pour éviter diaphonie/interférence des noeuds adjacents. Après avoir changé le réglage de la fréquence, appuyez sur l'interrupteur de comptage de la fréquence de ré-initialiser le détecteur. Pour vérifier la fréquence de fonctionnement d'une boucle reportez-vous à la section de fréquence de comptage. Pour déterminer si la diaphonie entre les boucles adjacentes se produit, reportez-vous à la section Affichage de sensibilité UltraMETER.

## Affichage de sensibilité UltraMETER™

Affichage de sensibilité the UltraMETER™ simplifie le processus d'installation en affichant le réglage de la sensibilité nécessaire pour détecter un véhicule sur la boucle. Pour utiliser cette fonctionnalité, observer l'écran alors qu'un véhicule se déplace en position sur la boucle, notez le numéro affiché, puis ajuster le réglage de sensibilité (commutateur rotatif) à la position affichée.

En fonctionnement normal, lorsqu'un véhicule n'est pas sur la boucle, l'affichage est vierge. Les effets de diaphonie ou d'autres interférences peuvent être observés sur l'écran lorsque la boucle est vacante. Interférence ou diaphonie provoquera l'affichage pour indiquer un niveau, généralement de 8 ou 9. Il peut être nécessaire d'observer l'écran pendant une minute ou deux pour voir à cet effet. Changez la fréquence pour éviter la diaphonie.

## Réglage de la sensibilité ity setting

L'interrupteur rotatif 10 broches permet un réglage précis du niveau de détection. Le niveau de sensibilité augmente de la position 9 à 0 à la position 0 étant la sensibilité la plus faible. Les applications typiques nécessitent un réglage de 3 ou 4. The UltraMETER™ affichage de sensibilité simplifie le processus d'installation en affichant le réglage de la sensibilité nécessaire pour détecter un véhicule sur la boucle. Pour utiliser cette fonctionnalité, observer l'écran alors qu'un véhicule se déplace en position sur la boucle, notez le numéro affiché, puis ajuster le réglage de sensibilité (commutateur rotatif) à la position affichée.

## Compte de fréquence / Reset

Appuyez sur le commutateur de fréquence comte et compter le nombre de clignotements de la LED rouge. Chaque flash représente 10kHz. Pour aider à prévenir les interférences lorsque plusieurs détecteurs sont utilisés pour les lignes adjacentes, effectuer un comptage de la fréquence sur chaque détecteur pour confirmer que les fréquences de fonctionnement sont différents. Après un cycle de compte de fréquence, le détecteur réinitialise

## Boost de sensibilité automatique

Le Boost de sensibilité automatique provoque la sensibilité d'augmenter après la détection initiale. Cette fonctionnalité est utile pour prévenir l'abandon lors de la détection de véhicules haute-lit. La sensibilité revient à son niveau normal après que le véhicule quitte la boucle. Point décimal sur l'afficheur indique l'ASB sur.

## Sortie de présence output

Les paramètres de présence fournit deux sélections, la sortie peut être réglée pour présence infinie ou présence normale. Causes de présence infinies la sortie de rester en mode tant que le véhicule demeure sur la boucle de détection. Normal présence provoque la sortie pour remettre à zéro après 5 minutes. N'utilisez pas le paramètre de présence normale à moins que l'ouverture est protégée par un dispositif de sécurité secondaire tels que la CISR-4 X.

## Détecter-stop (DOS™)

Le detect-stop affecte B/b (inversé B sortie). Cette fonction exige qu'un véhicule fait un arrêt complet sur la boucle pour la sortie à activer. Cette fonctionnalité est utile dans les cas où le trafic transversal provoque la détection. detect-on-stop affects B and /B (inverted B output). This function requires that a vehicle come to a complete stop on the loop for the output to activate. This feature is useful in cases where cross-traffic causes the detection.

## Sortie B

Paramètres de sortie B permettent des impulsions sur l'entrée, des impulsions à la sortie, sortie B même comme présence et faute de boucle.

## Fail Safe / pas sûr

Causes de définir l'ULT-PLG pour activer la sortie de la présence à l'événement ne parviennent pas un échec de la boucle. Fail sûr paramètre provoque l'ULT-PLG ne pas à activer la sortie de la présence dans le cas où une défaillance de la boucle

## Controls and Indicators

### BOOST DE SENSIBILITÉ AUTOMATIQUE

	DIP Position de l'interrupteur 8
ASB a permis	sur
ASB hors	hors

### PRÉSENCE

	DIP Position de l'interrupteur 7
NORMAL	sur
INFINI	hors

### DÉTECTER-MARCHE-ARRÊT (DOS)

	DIP Position de l'interrupteur 6
DOS sur	sur
DOS horsoff	hors

### SORTIE B

MODE	Position de l'interrupteur DIP	
	4	5
Impulsion sur l'entrée	sur	sur
Impulsion sur la sortie (1)	hors	sur
B même que A	sur	hors
Boucle Faute	hors	hors

(1) Not used when DOS is selected

(1) n'est pas utilisé lorsque le DOS est sélectionné

### FAIL SAFE / SÉCURISÉ

	DIP Position de l'interrupteur 3
Sûr en cas d'échec	sur
Fail Safe	hors

### PARAMÈTRES DE FRÉQUENCE

FRÉQUENCE	DIP Position de l'interrupteur	
	2	1
Faible	sur	sur
Moyenne basse	sur	hors
Moyenne élevée	hors	sur
Haute	hors	hors

### RÉGLAGE DE LA SENSIBILITÉ

Sensibilité	Position 0.....9
	Faible... haut

### D DÉTECTER / FRÉQUENCE COUNT

	Red LED
Présence détectée	sur
Aucune présence	hors
Compte de fréquence	clignotant

### ULTRAMETER™ AFFICHAGE

Indique le réglage de la sensibilité nécessaire pour la détection de véhicule

### COMTE DE FRÉQUENCE / RESET

Appuyez sur pour commencer le nombre de fréquences, ré-Initialise après dépouillement



## Connexions

Broche du connecteur	Description
1	Boucle
2	Boucle
3	Power + (12VDC... 24VDC)
4	Pas de connexion
5	Pas de connexion
6	Sortie B
7	B sortie inversée
8	Sortie de présence
9	Power + (12VDC... 24VDC)
10	Commune

## Dépannage

Symptôme	Cause possible	Solution
LED verte clignote	Fil en boucle ouverte ou court-circuit	Vérifier la résistance de la boucle sur les broches boucle approprié sur le connecteur de carte de contrôle, .5 va de 5 $\omega$ .
LED verte clignote, 2 rapide	Boucle a été précédemment mises en court-circuit ou ouvrir	Vérifier la résistance de la boucle sur la boucle des broches sur le connecteur de la carte de contrôle.
Restes de détecteur à détecter après que véhicule a quitté la boucle	<ol style="list-style-type: none"><li>1. Défectueux en boucle</li><li>2. Mal sertis terminaux</li><li>3. Connexions desserrées</li></ol>	<ol style="list-style-type: none"><li>1. Tester megger de fil de la boucle à la terre, doit être &gt; 100 mégohms</li><li>2. Vérifier les connexions de boucle aux bornes</li><li>3. Les épissures de cocher sont correctement soudés et étanche à l'humidité</li><li>4. Affichage ULTRAMETER observer, niveau indiqué sur l'affichage indique décalage de fréquence résiduelle de boucle vacant à la présence de véhicule, appuyez sur le commutateur de fréquence nombre de ré-initialiser le détecteur</li></ol>
Détection intermittente	<ol style="list-style-type: none"><li>1. Défectueux en boucle</li><li>2. Mal sertis terminaux</li><li>3. Connexions desserrées</li><li>4. Diaphonie entre les boucles adjacentes</li></ol>	<ol style="list-style-type: none"><li>1. Tester megger de fil de la boucle à la terre, doit être &gt; 100 mégohms</li><li>2. Vérifier les connexions de boucle aux bornes</li><li>3. Les épissures de cocher sont correctement soudés et étanche à l'humidité</li><li>4. Définir les boucles adjacentes à des fréquences différentes (voir Réglage de la fréquence)</li></ol>
Pas de détection	<ol style="list-style-type: none"><li>1. Boucle en court-circuit ou ouvrir</li><li>2. Boucle sensibilité réglé trop basses</li></ol>	<ol style="list-style-type: none"><li>1. Résistance de boucle de cocher sur la ligne appropriée broches sur le connecteur de carte de contrôle, .5 va de 5 <math>\omega</math>.</li><li>2. Avec véhicule sur boucle, observer ULTRAMETER afficher, réglage de sensibilité au niveau indiqué sur l'affichage</li></ol>

---

## Boucle Installation

---

### NOUVELLE DALLE POUR

Ty-wrap 1-1/4 po en PVC tuyau vers le haut de la barre d'armature dans la taille et la configuration de la boucle (ex. 4 « x 8 »). Alors ty-envelopper la boucle vers le haut du châssis en PVC. Cela stabilise la boucle lors de la coulée et la sépare de l'armature.

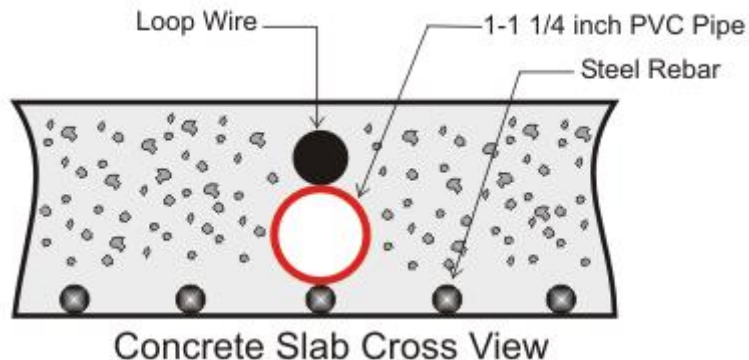

### SVU LA SURFACE EXISTANTE DE LA COUPE

Couper 1" profondément dans la surface existante, placer une coupe dans les coins pour éviter les bords tranchants d'endommager le fil de la boucle de 45°. Encocher pour la connexion « T » où le câble est connecté à la boucle. Retirer tous les débris de la coupe finie avec l'air comprimé. Placez la boucle dans la coupe de la scie. Placer le matériau de backer dans la scie entaille au dessus de la boucle et le pack étroitement. Placez un scellant de qualité sur la scie coupe afin de sceller la surface.

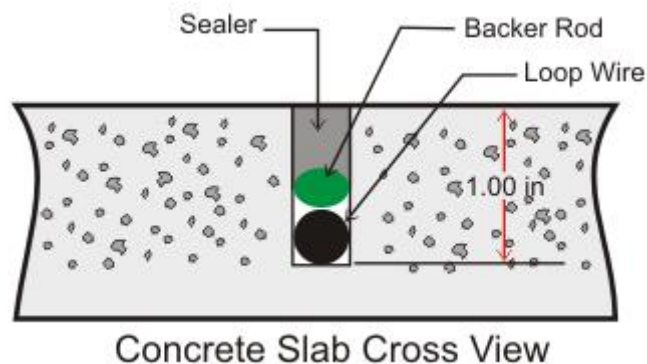

### REFAIRE SURFACE ASPHALTE

Scie à découper la surface existante 3/4" de profondeur et place un 45° couper dans les coins pour éviter les bords tranchants d'endommager le fil de la boucle. Retirer tous les débris de la coupe finie avec l'air comprimé. Placez sable sur le fil en boucle à la surface et le pack étroitement. Poser le nouvel asphalte

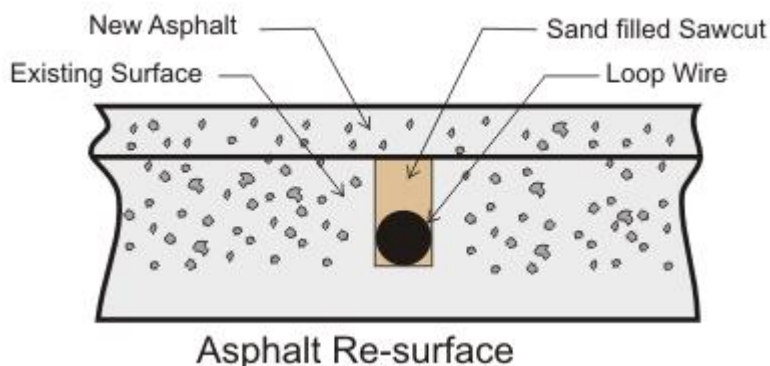

### Directives d'Installation générale

- Utilisez des boucles EMX Lite préformé pour des installations rapides, fiables et conformité CE.
- L Câble (fil détecteur de boucle) doit être tordu un minimum de 6 tours / pied pour éviter les effets de bruit ou d'autres interférences.
- Hauteur de détection est d'environ 70 % du côté le plus court de la boucle. Exemple : hauteur de détection pour une boucle de 4 « x 8 » =  $48 \text{ "x}.7 = 33,6\text{"}$

---

## Informations de commande

---

ULT-PLG ULTRALOOP véhicule détecteur de boucle

---

## Accessories

---

PR-XX EMX Lite préformé Loops™

---

## Garantie

---

### **WARRANTY**

EMX Industries Incorporated warrants all products to be free of defects in materials and workmanship for a period of two years under normal use and service from the date of sale to our customer. This warranty does not cover normal wear and tear, abuse, misuse, overloading, altered products, damage caused by incorrect connections, lightning damage, or use other than intended design.

There is no warranty of merchantability. There are no warranties expressed or implied or any affirmation of fact or representation except as set forth herein.

EMX Industries Inc. sole responsibility and liability, and the purchaser's exclusive remedy shall be limited to the repair or replacement at EMX Industries option of a part or parts found not conforming to the warranty. In no event shall EMX Industries Inc. be liable for damages of any nature, including incidental or consequential damages, including but not limited to damages resulting from non-conformity, defect in material or workmanship.

*effective date January 1, 2002*



BLANK PAGE



BLANK PAGE



4564 Johnston Parkway  
Cleveland, Ohio 44128  
United States of America  
[www.emxinc.com](http://www.emxinc.com)

Technical Support: (216) 834-0761  
[technical@emxinc.com](mailto:technical@emxinc.com)

Sales: (216) 518-9888  
Fax: (216) 518-9884  
[salesupport@emxinc.com](mailto:salesupport@emxinc.com)



# Tilt-A-Way HYJG 1

## Menu Programme Control Board

### 09/03/2016

Pour accéder au menu principal, appuyez et maintenez le bouton SW2 pendant environ 4 secondes.  
Pour voir la presse menus et relâchez le bouton SW4 pour faire défiler, et SW3 pour faire défiler vers le bas.  
Pour entrer dans le menu ou sous-menu presser et relâcher le bouton SW1.  
Pour enregistrer les modifications, appuyez sur sous-menus et bouton de déverrouillage SW1.  
Pour quitter les sous-menus, ou le menu principal, appuyez sur et relâchez le bouton SW2.

- TEMPS RÉEL STATUS. Ce menu est utile pour résoudre les problèmes avec le système de grille.
  - Statut d'entrée. Dans ce sous-menu, vous pouvez visualiser les entrées sont actives ou inactives.

bouton d'ouverture de l'état d'entrée "Input clair / Input affirmé"  
Etat d'entrée bouton de fermeture "Input clair / Input affirmé"  
bouton d'arrêt d'état d'entrée "Input clair / Input affirmé"  
Etat d'entrée unique bouton "Input clair / Input affirmé"  
Etat d'entrée inverse ouvert, borne "Input clear / Input a affirmé"  
Entrée état timer set "Input clair / entrée affirmé"  
Entrée état temps de maintien "Input clair / Input affirmé"  
Etat d'entrée aux minuterie "Entrée Taquet / Entrée affirmé"  
Etat d'entrée UL reset (à bord) "Input clair / Input affirmé"  
Etat d'entrée à distance (n.ö. de contact) "Contact ouvert / Contact fermé"  
Etat d'entrée à distance (N.C. de contact) "Contact ouvert / Contact fermé"  
fente de la boucle d'état d'entrée # J3 "Input clair / Input affirmé"  
fente de la boucle d'état d'entrée # J5 "Input clair / Input affirmé"  
fente de la boucle d'état d'entrée # J7 "Input clair / Input affirmé"  
Etat d'entrée auxiliaire # 1 "Entrée claire / Entrée affirmé"  
Etat d'entrée auxiliaire # 2 "Entrée claire / Entrée affirmé"  
Etat d'entrée feuille # 1 fermer obstrue bord "Input clair / Input affirmé"  
Etat d'entrée feuille # 1 bord obstruent ouvert "Input clair / Input affirmé"  
Etat d'entrée feuille # 1 limite de fermeture "Input clair / Input affirmé"  
Etat d'entrée feuille # 1 limite d'ouverture "Input clair / Input affirmé"  
Etat d'entrée feuille # 2 à proximité obstrue bord "Input clair / Input affirmé"  
Etat d'entrée feuille # 2 bord obstruent ouvert "Input clair / Input affirmé"  
Etat d'entrée feuille # 2 limite de fermeture "Input clair / Input affirmé"  
Etat d'entrée feuille # 2 limite d'ouverture "Input clair / Input affirmé"

Etat de sortie. Dans ce sous-menu, vous pouvez voir les relais de sortie de sorcière sont verrouillés ou déverrouillés.

Etat de sortie piégeage (K1) "relais non activé / relais excité"  
Etat de la sortie pré-alarme (K2) "relais non activé / relais excité"  
Etat de la sortie auxiliaire # 1 (K3) "relais non alimenté / relais excité"  
Etat de la sortie auxiliaire # 2 (K4) "relais non alimenté / relais excité"  
Etat de la sortie auxiliaire n ° 3 (K5) "relais non alimenté / relais excité"

Moteur actuel. (Pour le modèle DCM uniquement) Ce sous-menu est utilisé uniquement pour pour afficher tirage amp du moteur de sorte que la valeur appropriée peut être insérée dans le seuil de sécurité sous-menu.

Feuille # 1 seuil d'écart maximal, dernier cycle (porte arrêté)

X.X A (porte arrêté)

Feuille Courant moteur # 1 (portail mobile)

Approx Courant moteur (portail mobile)

x.x (changements de cette valeur que la porte se déplace à travers un cycle. Suivre la plus forte valeur au cours du cycle pour entrer dans un bon réglage du seuil de sécurité sous-menu feuille # 1) A

Feuille # 2 seuil d'écart maximal, dernier cycle (porte arrêté)

X.X A (porte arrêté)

Feuille Courant moteur # 1 (portail mobile)

Approx Courant moteur (portail mobile)

x.x (changements de cette valeur que la porte se déplace à travers un cycle. Suivre la plus forte valeur au cours du cycle pour entrer dans un bon réglage du seuil de sécurité sous-menu feuille # 2) àLa batterie Tension. (Pour le modèle DCM uniquement) Ce sous-menu affiche la tension étant fournie à la carte logique. Toute tension sur 24 Vcc montrera que 24 volts.

- Feuille # 1 / 24,0 volts
- Feuille # 2 / 24,0 volts
  - TIMING ET OPTIONS. Dans ce menu, vous pouvez régler les paramètres de l'utilisateur.

- o Réglages de base

heure de l'horloge actuelle (réglée en usine en temps de montagne) "12:01 am"

Date actuelle du calendrier "01/01/2013"

Auto-Close retard (réglé en usine à 10 secondes) "OFF / 15:00"

Fermer commande sur manèges fermeture automatique (réglage d'usine Enabled) "Activé / Désactivé"

entrée unique règle la minuterie fermeture automatique (réglage d'usine Enabled) "Activé / Désactivé"

entrée unique sens inverse (réglage d'usine Enabled) "Activé / Désactivé"

Pause délai avant inversion de sens (réglage d'usine Enabled) "Activé / Désactivé"

- Réponses de sécurité

le fonctionnement du moteur maximum (0:30 secondes réglée en usine) "midi 05-01:30"

inversion de mouvement sur la sécurité (réglé en usine Enabled) "Activé / Désactivé"

Sécurité règle la minuterie (réglage d'usine Enabled) de fermeture automatique "Désactivé / Activé"

la sécurité intrinsèque (pour définir le modèle DCM seule usine Désactivé) "Activé / Désactivé"

seuil de sécurité Feuille # 1 fermeture (pour le modèle DCM seule valeur fixée à l'usine, la sécurité intrinsèque doit être vérifiée par mois) "0.0 A à 20,0 A"

seuil de sécurité Feuille # 1 ouverture (pour le modèle DCM seule valeur fixée à l'usine, la sécurité intrinsèque doit être vérifiée par mois) "0.0 A à 20,0 A"

seuil de sécurité Feuille # 2 fermeture (pour le modèle DCM seule valeur fixée à l'usine, la sécurité intrinsèque doit être vérifiée par mois) "0.0 A à 20,0 A"

seuil de sécurité Feuille # 2 ouverture (pour le modèle DCM seule valeur fixée à l'usine, la sécurité intrinsèque doit être vérifiée par mois) "0.0 A à 20,0 A"

appel du moteur ignorer période (réglé en usine 1.0 secondes) "0.0 secondes à 2,0 secondes"

Position Feedback Obstruction Detect (pour portail hydraulique uniquement) (réglé en usine Enabled) "Désactivé / Activé"

Surveillé Obstruction Edge "Activé / Désactivé"

- Réglage de la vitesse (pour le modèle DCM uniquement)

position de la porte pour la rampe jusqu'à la fin (réglé en usine 5%) "XX%"

position de la porte pour rampe descendante démarrage (réglé en usine 80%) "XX%"

arrêt lente descente de la rampe sur la porte inversion (réglé en usine 0,5 secondes) "0.0 secondes à 3,0 secondes"

vitesse rampe du moteur de départ (réglé en usine 60%) "XX%"

la vitesse maximale du moteur (réglé en usine à 100%) "XX%"

la vitesse finale de la rampe du moteur (réglé en usine 40%) "XX%"

Lockout annexe. Lorsque le calendrier de verrouillage est réglé la porte ne sera pas ouvert jusqu'à ce que le calendrier de lock-out se termine, sauf pour une boucle de sortie libre va ouvrir la porte, ou une entrée à minuterie terminale jeu entrée I7.

Entrée verrouillage permet annexe # 1 "Activé / Désactivé"

Horaire de début de verrouillage d'entrée # 1 "fixé pour le temps de commencer à lockout am ou pm et jour de la semaine"

Entrée fin de lock-out annexe n ° 1 "fixé pour le temps de mettre fin à un lock-out am ou pm et jour de la semaine"

Répétez l'opération pour tous les jours que le verrouillage est nécessaire.

Auto-Ouvrir le calendrier. Lorsque le calendrier d'ouverture automatique est réglé aucune fonction fermera la porte jusqu'à ce que le calendrier d'ouverture automatique se termine.

porte à ouverture automatique permettent annexe # 1 "Activé / Désactivé"

Auto-Open Gate heure de début Annexe # 1 "fixé pour le temps de commencer h auto-ouvert ou h et jour de la semaine"

Auto-porte ouverte fin Horaire du temps # 1 "fixé pour temps de mettre fin h auto-ouvert ou h et jour de la semaine"

Répétez l'opération pour tous les jours à ouverture automatique est nécessaire.

Batterie (pour le modèle DCM uniquement)

Fail-Safe / Fail-sécurisé sélection "sécurité positive / échec sécurisé"

Tension de la batterie de décrochage (réglé en usine de 18,0 volts) "17,0 à 23,0"

tension de rétablissement de la batterie (réglé en usine 20,0 volts) "18,0 à 23,0"

Auxiliaire I / O

auxiliaire # 1 entrée affectation de la fonction "non utilisé / open / close / stop / cale unique / minuterie / marche arrière en boucle ouverte / ouverture bord de sécurité / bord de sécurité de fermeture / UL piégeage remise à zéro"

auxiliaire # 2 entrée affectation de la fonction "non utilisé / open / close / stop / cale unique / minuterie / marche arrière en boucle ouverte / ouverture bord de sécurité / bord de sécurité de fermeture / UL piégeage remise à zéro"

Sortie auxiliaire # 1 fonction "sortie désactivée / secondaire piégeage alarme / maintien aux relais lorsque la maintenance due / hold aux relais fermeture automatique impulsion de retard / déverrouillage / impulsion aux relais fermer l'interrupteur de fin de course / impulsion aux relais limite d'ouverture commutateur / impulsion aux relais ouverts mouvement / impulsion aux relais à proximité mouvement / tenir aux relais fermer l'interrupteur de fin de course / tenir aux relais de fin de course d'ouverture / tenir aux relais mouvement d'ouverture / hold aux relais mouvement de fermeture / impulsion aux relais sur motion pré-alarme / impulsion aux relais sur l'ouverture pré-alarme seulement / impulsion aux relais fermeture Pré alarme seulement / impulsion aux relais entrée auxiliaire # 1 / hold aux relais entrée auxiliaire n ° 1 / impulsion aux relais entrée auxiliaire # 2 / hold aux relais entrée auxiliaire # 2 / hold aux relais sur une motion / hold aux relais sur la boucle d'armement assertion "

Sortie auxiliaire n ° 1 durée d'impulsion "0,1 secondes à 5,0 secondes"

Sortie auxiliaire fonction # 2 "sortie désactivée / secondaire piégeage alarme / maintien aux relais lorsque la maintenance due / hold aux relais fermeture automatique impulsion de retard / déverrouillage / impulsion aux relais fermer l'interrupteur de fin de course / impulsion aux relais limite d'ouverture commutateur / impulsion aux relais ouverts mouvement / impulsion aux relais à proximité mouvement / tenir aux relais fermer l'interrupteur de fin de course / tenir aux relais de fin de course d'ouverture / tenir aux relais mouvement d'ouverture / hold aux relais mouvement de fermeture / impulsion aux relais sur motion pré-alarme / impulsion aux relais sur l'ouverture pré-alarme seulement / impulsion aux relais fermeture Pré alarme seulement / impulsion aux relais entrée auxiliaire # 1 / hold aux relais entrée auxiliaire n ° 1 / impulsion aux relais entrée auxiliaire # 2 / hold aux relais entrée auxiliaire # 2 / hold aux relais sur une motion / hold aux relais sur la boucle d'armement assertion "

Sortie auxiliaire n ° 2 durée d'impulsion "0,1 secondes à 5,0 secondes"

Sortie auxiliaire fonction # 3 "sortie désactivée / secondaire piégeage alarme / maintien aux relais lorsque la maintenance due / hold aux relais fermeture automatique impulsion de retard / déverrouillage / impulsion aux relais fermer l'interrupteur de fin de course / impulsion aux relais limite d'ouverture commutateur / impulsion aux relais ouverts mouvement / impulsion aux relais à proximité mouvement / tenir aux relais fermer l'interrupteur de fin de course / tenir aux relais de fin de course d'ouverture / tenir aux relais mouvement d'ouverture / hold aux relais mouvement de fermeture / impulsion aux relais sur motion pré-alarme / impulsion aux relais sur l'ouverture pré-alarme seulement / impulsion aux relais fermeture Pré alarme seulement / impulsion aux relais entrée auxiliaire # 1 / hold aux relais entrée auxiliaire n ° 1 / impulsion aux relais entrée auxiliaire # 2 / hold aux relais entrée auxiliaire # 2 / hold aux relais sur une motion / hold aux relais sur la boucle d'armement assertion "

Sortie auxiliaire n ° 3 durée d'impulsion "0,1 secondes à 5,0 secondes"

Boucle et cession à distance

affectation de fonctionnalité Loop, slot J3 "slot de boucle désactivé boucle / sécurité / sans boucle de sortie / boucle d'ombre / armement boucle"

affectation de fonctionnalité Loop, slot J5 "slot de boucle désactivé boucle / sécurité / sans boucle de sortie / boucle d'ombre / armement boucle"

affectation de fonctionnalité Loop, slot J7 "slot de boucle désactivé boucle / sécurité / sans boucle de sortie / boucle d'ombre / armement boucle"

Télécommande affectation des boutons "à distance ne sont pas utilisés open-seule commande / commande / single"

#### Porte physique Setup

Nombre de portes leafs installés "1/2" 1 est la porte simple, 2 est maître esclave

Type de moteur (doit être pompe hydraulique AC) "DC orientée / DC

entraînement direct pompe hydraulique / AC"

Position feed-back capteur installé (pour le modèle HYJG seul ensemble de l'usine Enabled) "Activé / Désactivé"

droite de sélection gauche-main "/ gauche à droite" Ceci permet de sélectionner ce qui porte commence d'abord dans un système maître-esclave.

Feuille stagger delay "0.0 secondes à 15,0 secondes"

#### Un service

- Lockout Service

Définir un lock-out de service pour tout l'entretien "contrôleur activé / désactivé du contrôleur (portail ne bouge pas)"

- rappels Maintenance

entretien de rappel de service non nécessaire / Maintenance nécessaire

Réinitialiser le cycle de service compteur à zéro "non / oui"

Définir rappel de service sur compteur de cycle "off / xxx (réglé en usine à 2500"

Définir rappel de service ou après la date "Activé / Désactivé"

Si le service de rappel ou après la date est activée, la date peut être réglée ici "21/08/2021"

- relais de test

Test de relais / Latch "Les relais ne verrouillées / verrouillage relais K1 / verrouillage relais K2 / verrouillage relais K3 / verrouillage relais K4 / verrouillage relais K5"

- config usine. Ce sous-menu est pour une utilisation en usine.

Attention! Appliquer volts et couper étalonnage "24,0 volts"

Attention! Zéro vie compteur de temps de cycle "non / oui"

Attention! Réinitialiser tous les réglages par défaut "non / oui"

#### Statistiques

- Porte Cycle Count

comptage de cycle total de la durée de vie de grille (000000)

Comptage de cycles depuis dernière remise de service (00000)

- Moteur bord # 1 bus. Ce sous-menu est une utilisation en usine.

- Moteur bord # 2 bus. Ce sous-menu est une utilisation en usine.

journaux d'événements

- **General Event Log**  
Event #1 (most recent)
- **Sécurité Event Log**  
Event # 1 (le plus récent)



BLANK PAGE FOR NOTES