



**TILT-A WAY  
DCM  
VERTICAL PIVOT GATE  
24 VOLT DC**

**Vehicular Class  
I, II, III, and IV  
Operators & Parts Manual**



**NOTE: WHEN ORDERING PARTS, PLEASE HAVE YOUR SERIAL NUMBER  
TO ENSURE THE CORRECT PARTS ARE SENT TO YOU.**

**Manual subject to change with out notice.**

**Ideal Manufacturing, Inc. • 2011 Harnish Blvd. • Billings, MT 59101**

**P (406) 656-4360 • F (406) 656-4363**

# GROUP 27 BATTERY

600 COLD CRANKING AMPS

160 MIN RESERVE CAPACITY

TABLE OF CONTENTS

<b>DESCRIPTION</b>	<b>PAGE NO.</b>
WARRANTY	BEGINNING
SAFETY INFORMATION	PAGE 1
CLASS OF VEHICULAR GATES	PAGE 1
PROTECTION AGAINST ENTRAPMENT	PAGE 1
GATE SPECIFICATIONS	PAGE 2
ALTERNATE FENCE SCHEMES	PAGE 3
GENERAL INFORMATION	PAGE 4
USER INTERFACE BOARD GENERAL INFORMATION	PAGE 5
LOGIC BOARD GENERAL INFORMATION	PAGE 6
MOTOR CONTROL BOARD GENERAL INFORMATION	PAGE 7
BASIC ELECTRICAL HARDWARE	PAGE 8
SINGLE GATE ELECTRICAL DIAGRAM	PAGE 9
MASTER GATE ELECTRICAL DIAGRAM	PAGE 10
SLAVE GATE ELECTRICAL DIAGRAM	PAGE 11
OPERATOR FIELD INSTALLATION FOR ASSEMBLED GATE	PAGE 12, 13
OPERATOR FIELD INSTALLATION FOR UNASSEMBLED GATE	PAGES 12, 13
BALANCE SYSTEM ADJUSTMENT AND SAFETY WARNINGS	PAGES 14, 15
GENERAL ARRANGEMENT	PAGES 16, 17
GENERAL MAINTENANCE	PAGE 16, 17
BARRIER CARRIAGE – RIGHT HAND SHOWN LEFT OPPOSITE	PAGES 18, 19
GEARMOTOR WITH COMPONENTS	PAGES 20, 21
BARRIER UNIT	PAGES 22
BALANCE SYSTEM – FRONT SHEAVE	PAGE 23
BALANCE SYSTEM -REAR SHEAVE	PAGE 24
COVERS AND ACCESS GUARDS	PAGE 25
BALANCE SYSTEM SPRING TENSIONER UNIT	PAGE 26, 27
ACTUATING SPROCKET AND BARRIER ADJUSTMENT	PAGES 28, 29
BALANCE SYSTEM COMPONENT REPLACEMENT INSTRUCTIONS	PAGES 30
PROGRAM MENU	PAGES 31 THRU 36
REFLECTIVE TYPE PHOTO EYE	PAGE 37
LOOP WIRING	PAGE 38
LOOP DECTECOR MANUAL	PAGES 39 THRU 50
LOOP SOCKET DIAGRAM	PAGES 51
MONITORED REVERSING EDGE INSTALLATION	PAGE 52
STANDARD REVERSING EDGE INSTALLATION	PAGE 53
SAFETY WARNING LIGHT	PAGE 54
ELECTROMAGNETIC LOCK DIAGRAM	PAGE 55
EMERGENCY STOP COMPONENTS	PAGE 56
MANUAL KEY SWITCH	PAGE 57
GATE OPEN HORN & LIGHT INDICATOR	PAGE 58
REMOTE CONTROL STATION PEDESTAL AND GATELOCK	PAGE 59
RADIO RECEIVER THREE BUTTON LIFTMASTER	PAGE 60
RADIO RECEIVER SINGLE BUTTON LIFTMASTER	PAGE 61
LIFTMASTER MANUAL	PAGE 62 THRU 69
PHOTO EYE – SURFACE MOUNT STANCHION	PAGE 70
MARNETIC LOCK ASSEMBLY	PAGE 71
TROUBLE SHOOTING GUIDE	PAGE 72 THRU 74
OMRON REFLECTIVE TYPE PHOTO EYE	PAGE 75
WARNINGS IN FRENCH	BACK OF MANUAL
BATTERY CHARGER MANUAL	SEE CHARGE MANUAL



**2011 Harnish Blvd.  
Billings, MT 59101**

---

**INFO@TILTAWAY.COM  
406-656-4360 800-523-3888**

## **Ideal Mfg., Inc. - Tilt-A-Way Limited Warranty**

Ideal Manufacturing, Inc. ("Ideal") warrants that, at the time of sale, this Tilt-A-Way vertical pivot gate ("product") will, in all material respects, conform to its applicable specification and will be free from defects in material and manufacture. This warranty does not extend to electrical components, nor does it extend to products or components not manufactured by Ideal. Ideal disclaims all warranties for such products or components, which carry only the original warranty, if any, of their original manufacturer. Ideal designates its rights under such manufacturer warranties to the buyer.

Ideal further warrants that the product will, with recommended maintenance and without being subjected to extraordinary or abnormal use or abuse, remain functional under this warranty for 3 years, which begins on the date of purchase.

**Any modification or alteration made to the product will void the warranty unless it is approved in writing by Ideal before any modification or alternation.** This exclusion does not apply to the normal installation of approved accessories and/or safety devices. This warranty shall not apply to equipment that has been (1) improperly installed or installed inconsistent with instructions; (2) subjected to negligence, accident, vandalism, or damage by severe weather, wind, flood, fire, or war; or (3) damaged through improper operation, maintenance, storage or abnormal use or abuse. **The proper operation of this product is dependent on your compliance with the instructions regarding installation, operation, maintenance, and testing. The warranty does not cover damage(s) or defects resulting from the failure to comply strictly with those instructions.**

This warranty is exclusive and is the only warranty given by Ideal and is in place of all others. This warranty supersedes any prior, contrary, or additional representations, whether oral, written, expressed, or implied. In no event shall Ideal be liable or responsible for incidental or consequential damage or any other direct or indirect damage loss, cost, expense, or fee.

This warranty does not cover or extend to any incidental expenses for the replacement of consumables (batteries, oil, grease, etc.), including labor, shipping, travel time, standby time, or loss of use that are incurred.

If the product fails to conform to the warranty parameters, the buyer must notify Ideal within a reasonable time and in no event more than thirty (30) days after the discovery of the nonconformity. Ideal will investigate and, in the event of an entitled warranty claim, will provide, at its option and

within a reasonable period of time, repair or replacement of any nonconforming products or components. Replacement products or components will conform to this warranty for the unexpired duration of the warranty period for the original, nonconforming product or component. Ideal reserves the right to supply used, reconditioned or repaired material for all warranty claims. This warranty does not cover or extend to any incidental expenses, including labor, shipping, travel time, standby time, or loss of use that are incurred for inspection or replacement of any nonconforming products or components.

In most cases replacement products or components will be handled as an advanced return scenario. This type of return is used when Ideal provides an advanced replacement of a suspect warranty part before the suspect part has been returned to Ideal. An invoice for the product or component cost and outgoing freight will be issued to the buyer. **Credit for the replacement product or component and shipping costs will be issued only after the suspect product or component has been returned to Ideal, inspected and approved as defective. Suspect products or components must be returned to Ideal no later than 60 days from the date the advanced replacement is shipped out to the buyer.** Replacement products or components will be shipped standard ground freight. If expedited shipping is required, the buyer will be responsible for any increase in shipping costs.

This warranty gives you specific legal rights. You may also have other rights which vary from state to state or province to province.

Contact Ideal Manufacturing Inc. for additional information and/or instructions about Ideal's warranty or warranty claim process.

## IMPORTANT SAFETY INFORMATION

**Before installing the installer should read and understand the owners manual and safety instructions. The owner should read, and keep this owners manual. Read and Follow All Instructions.**

### **WARNING-TO REDUCE THE RISK OF INJURY OR DEATH TO PERSONS**

1. Do not operate gate unless all safety devices are connected and working properly.
2. Do not permit children to play on or around a gate. Keep all controls out of reach from children.
3. Automatic gates are not intended for pedestrian use. Pedestrians must be supplied a separate entrance separate from the automatic gate.
4. Never operate an automatic gate system without visual contact so it can be shut down if necessary.
5. Access controls, are required, to be mounted at least 6 feet away from the gate and operator.
6. Disconnect all power before performing any maintenance on your gate or operator.
7. Keep your gate properly maintained-have a qualified service person make all repairs.
8. A qualified technician should test your gate monthly. The gate **MUST** reverse on contact with a rigid object or stop when an object activates a non-contact sensor. After adjusting the force of the limit of travel, retest the gate operator. Failure to adjust and retest the gate operator properly can increase the risk of injury or death.
9. The gate and operator must have two appropriate safety devices to match the gate class installation.
10. Operator and barrier must display warning signs on both sides, in view of operator.
11. Do not install added weight to the gate barrier, your barrier has been balanced at the factory, if you add weight to the gate barrier it will make your gate out of balance, which could cause it to malfunction.
12. Only qualified personnel should install this equipment. Failure to meet this requirement could cause severe injury and or death, for which the manufacturer cannot be held responsible.
13. Safety devices, such as photo eyes and reversing edges should be installed to provide protection for personal property and pedestrians.
14. Before turning the power on make sure that the correct voltage has been supplied to the electric motor and the equipment has been properly grounded.
15. Always keep people and objects away from the gate. **NO ONE SHOULD CROSS THE PATH OF THE MOVING GATE.**

## CLASS OF VEHICULAR GATES

### Glossary

#### **CLASS I-RESIDENTIAL VEHICULAR GATE OPERATOR (3.19)**

A vehicular gate operator (or system) intended for use in garages or parking areas associated with a residence of one to four single families.

#### **CLASS II-COMMERCIAL/GENERAL ACCESS VEHICULAR GATE OPERATOR (3.4)**

A vehicular gate operator (or system) intended for use in a commercial location or building such as multi-family housing unit (five or more single family unit), hotel, garages, retail store, or other buildings accessible by of servicing the general public.

#### **CLASS III-INDUSTRIAL/LIMITED ACCESS VEHICULAR GATE OPERATOR (3.11)**

A vehicular gate operator (or system) intended for use in an industrial location or building such as a factory or loading dock area or other locations not accessible by or intended to service the general public.

#### **CLASS IV-RESTRICTED ACCESS VEHICULAR GATE OPERATOR (3.20)**

A vehicular gate operator (or system) intended for use in a guarded industrial location or building such as an airport security area or other restricted access locations not servicing the general public, in which unauthorized access is prevented via supervision by security personal.

## INSTRUCTIONS FOR MANUAL OPERATION TILT-A-WAY MODEL DCM

**Note: Use the emergency release only when the gate is not moving**

1. Turn off all power supplies. Check inside operator to see if all springs and cables are in tact. If they have broken see page 12 and 13.
2. Locate the hair pin on the carriage, see page 17. Remove the hair pin, and then remove pivot pin.
3. Gate barrier can now be lifted manually from out at the end of gate.
4. Reverse procedure to operate gate normally.

## PROTECTION AGAINST ENTRAPMENT

Gate operator category	
Horizontal slide, vertical lift, and vertical pivot	Swing and vertical barrier (arm)
Entrapment protection types (a)	Entrapment protection types (a)
A, B1, B2, or D	A, B1, B2, C, OR D
<p>Note-The same type of device shall not be utilized for both entrapment protection means. Use of a single device to cover both the opening and closing directions is in accordance with the requirement; however, a single device is not required to cover both directions. A combination of one Type B1 for one direction and one Type B2 for the other direction is the equivalent of one device for the purpose of complying with the requirements of either entrapment protection means.</p> <p>(a) Entrapment protection types:                      Type A ó Inherent entrapment protection system. See 31.1.5.                      Type B1 ó Non-contact sensor (photoelectric sensor or the equivalent). See 31.1.6 ó 31.1.9.                      Type B2 ó Contact sensor (edge device or the equivalent). See 31.1.7 and 31.1.11 ó 31.1.13.                      Type C ó Inherent force limiting, inherent adjustable clutch or inherent pressure relief device. See 31.1.15 and 31.2.1.2 (b).                      Type D ó Actuating device requiring continuous pressure to maintain opening or closing motion of the gate. See 31.1.16 and 31.1.17.</p>	

## Specifications

<b>Tilt-A-Way DCM</b>		<b>24 vdc</b>	
<b>Operator Size</b>		<b>28" W x 48" T x 78"L</b>	
<b>Operator Weight</b>		<b>1,000 lbs.</b>	
<b>Maximum Barrier Size</b>		<b>96" T x 300"L-290 lbs</b>	
<b>Voltage</b>	<b>Hz</b>	<b>Cir. Reg. Amps.</b>	
<b>120 VAC</b>	<b>60</b>	<b>15</b>	<b>(for battery charger and accessories)</b>
<b>Motor Voltage</b>		<b>Control Board Voltage</b>	
<b>24 VDC</b>		<b>24 VDC</b>	
<b>Operator Speed to 90°</b>		<b>10-12 Seconds</b>	
<b>Gear Reducer Oil</b>		<b>Dexron III ATF (4 ½ ounces)</b>	
<b>Maximum Operating Temperature</b>		<b>70 C / 158 F</b>	

### CAUTION

**IT IS IMPORTANT THAT THE FLUID LEVEL OF ANY CONNECTED BATTERIES BE CHECKED ON A REGULAR BASIS. ALL BATTERIES WILL "GAS" AND LOSE SOME FLUIDS WHEN CONTINUOUSLY CONNECTED TO ANY CHARGING SOURCE.**

**Note: Minimum Circuit Requirements: 15-amp service at 120 VAC use copper wire only. For wire sizes consult the NEC (National Electric Code).**

LEFT HAND GATE SHOWN RIGHT HAND OPPOSITE  
OUTSIDE AREA

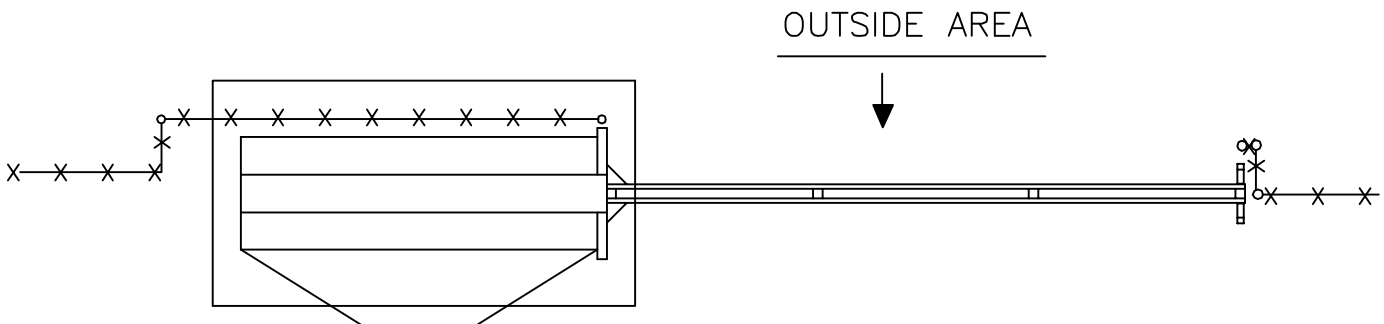
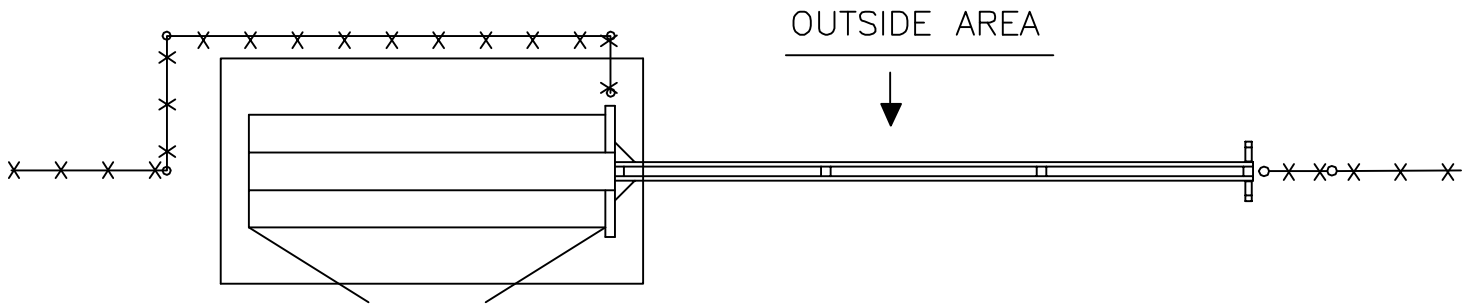
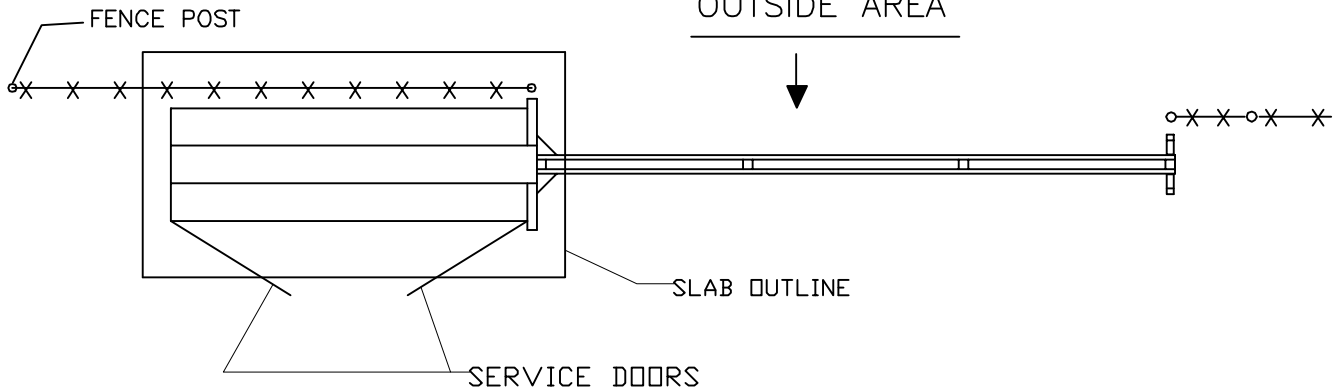

INDICATED ARE THREE MOST COMMON WAYS TO SET A TILT-A-WAY GATE  
 INDIVIDUAL CONDITIONS MAY REQUIRE A SPECIAL ARRANGEMENT  
 PROVIDE 44" MINIMUM CLEARANCE FOR SERVICE DOOR SWING

**ALTERNATE FENCE SCHEMES  
 TILT-A-WAY DCM - 24 VOLT DC**



# **Tilt-A-Way DCM**

## **GENERAL INFORMATION**

Tilt-A-Way DCM vertical pivot gate operates on two 12-vdc batteries (batteries not included). We recommend two 12-volt dc maintenance free lead acid deep cycle series 27 battery 85 amp hours or equivalent. The two 12-volt batteries are wired in series to supply 24 volts to the control boards. The wiring harness is equipped with ring terminals designed to connect to bolt type battery post (red wire to positive and black wire to negative). See wiring diagram on page 9 of this manual. Do not reverse battery polarity at the battery or circuit board. Severe damage will occur. Disconnect the battery and all power sources before installing any devices. Do not perform any welding while the motor cable is plugged into the control board or the battery connected. Serious damage to the control board and battery will occur.

Caution – Risk of explosion if battery is replaced by an incorrect type.

Dispose of used batteries according to the instructions.

Tilt-A-Way DCM vertical pivot gate has a programmable control board, which allows numerous programmable functions in various combinations (see programming section at end of this manual). The control board has current sense adjustments, which can be set to desired level. If the gate reverses direction twice and stops because of the current sensing the control board will have to be UL reset. This adjustment is factory set, but may need adjusting. Remember if the gate reverses direction when operated without contacting an obstruction, then minimizing sensitivity (increase force) may be required. Do not increase more than necessary.

A battery charger is supplied to keep the batteries charged. See charger owner's manual for proper operation.

A qualified technician should check, and adjust the controls for force, speed, and sensitivity monthly. The balance of the barrier should also be checked, and adjusted monthly by a qualified technician.

Tilt-A-Way DCM vertical pivot gate is supplied with two entrapment protection devices. Type A, inherent entrapment protection system, manufacturer by Polytron on the logic control board part number PEO202L. Type B2, contact-sensor edge, manufacturer by ASO Safety Solutions, model 25.30. Both of the entrapment protection devices must be connected and functioning properly before the gate operator is put into service. This is the maximum number of entrapment protection devices to be connected to the operator.

Tilt-A-Way DCM vertical pivot gate must be installed in a location so that enough clearance is supplied between the gate and adjacent structures when opening and closing to reduce the risk of entrapment.

# TILT-A-WAY DCM USER INTERFACE BOARD

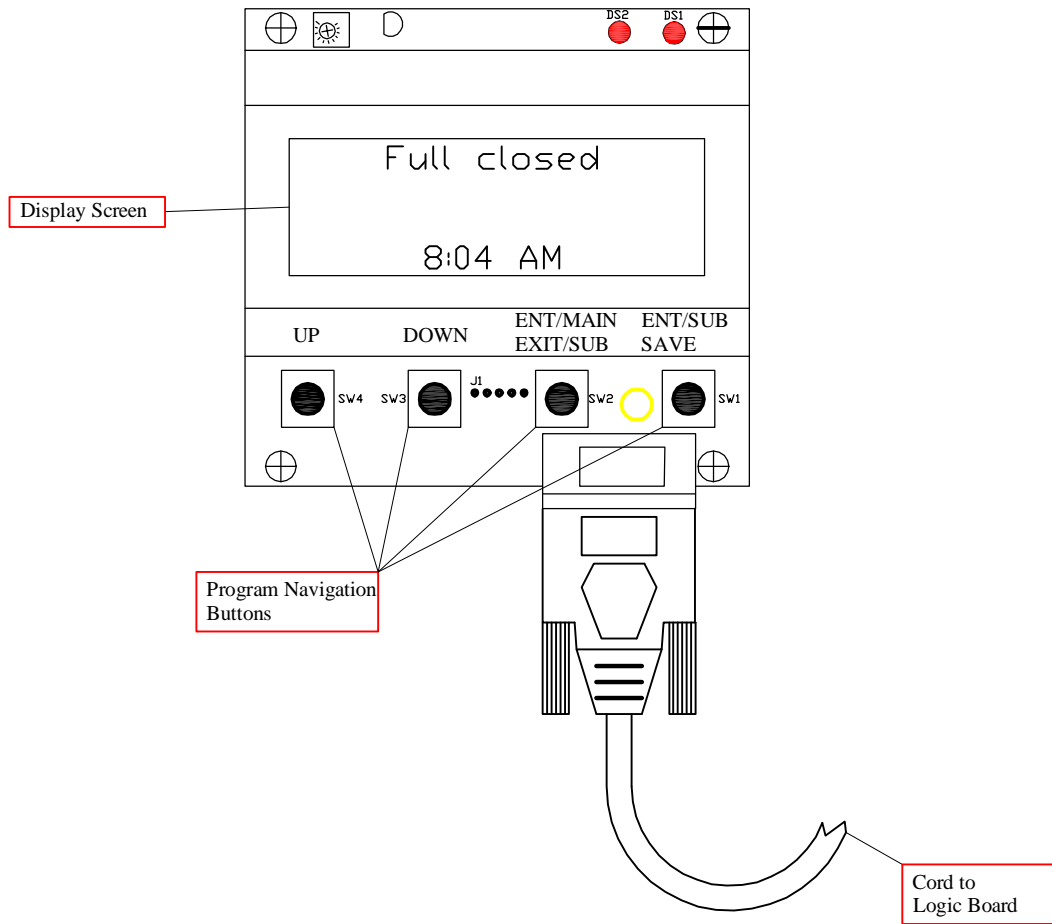

## TILT-A-WAY INTERFACE BOARD

The interface board has many functions for the end user to access.

The four push buttons on the board are used to navigate the programming.

Push and hold button SW2 for about 4 seconds to enter the main program menu.

When in the program menu push and release button SW2 to exit main menu, or sub menus.

Button SW4 will scroll up in the menus, and adjustable settings in sub menus.

Button SW3 will scroll down in the menus, and adjustable settings in sub menus.

Button SW1 will enter into menus, and sub menus.

When in sub menus, and after changing adjustable setting the SW1 button will save the change when pushed.

The interface does not have to be connected to the Logic Board for the gate to open or close.

See program section of this manual for full program menus.

# TILT-A-WAY DCM LOGIC CONTROL BOARD

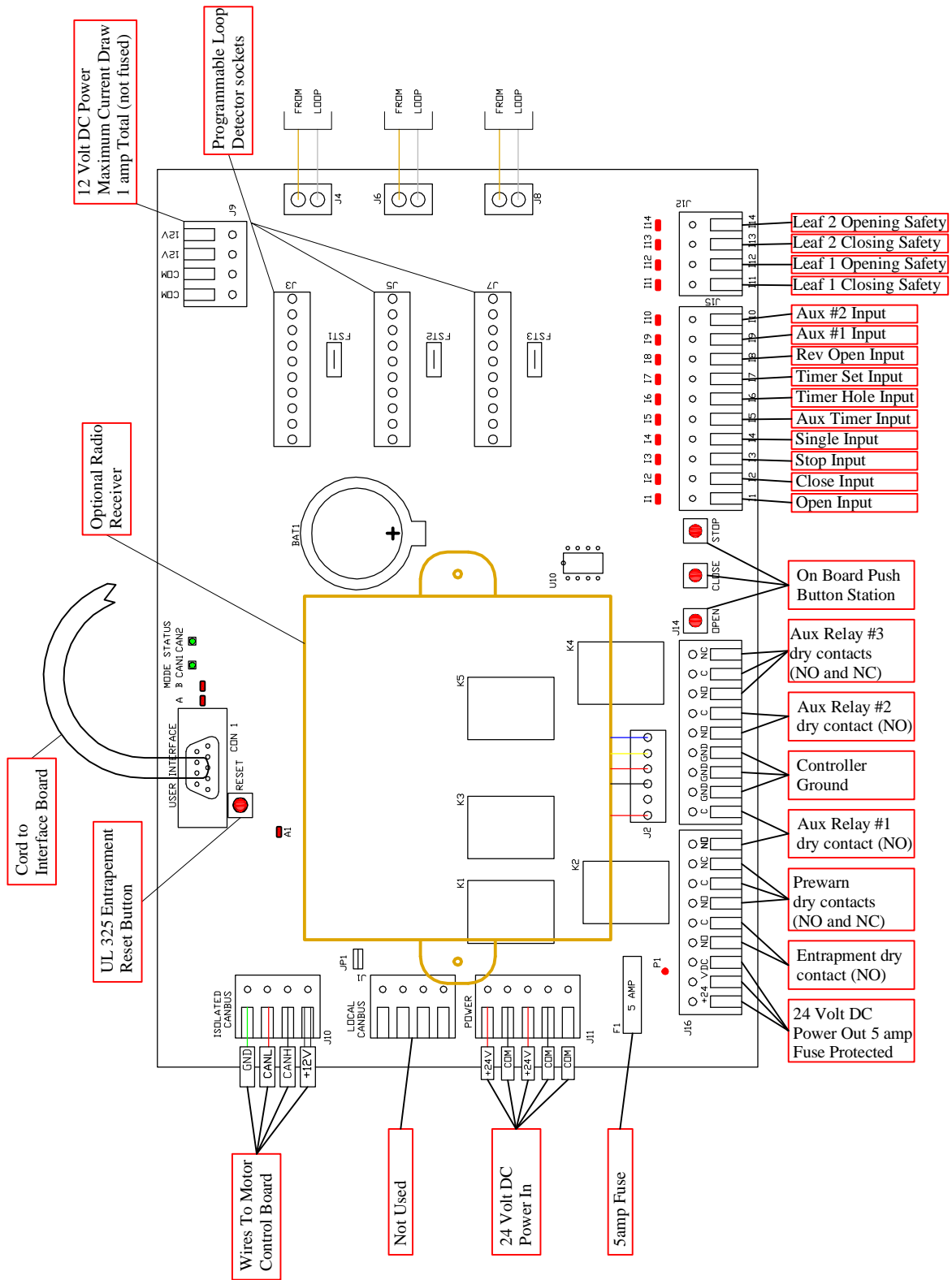

TILT-A-WAY  
DCM  
MOTOR CONTROL BOARD

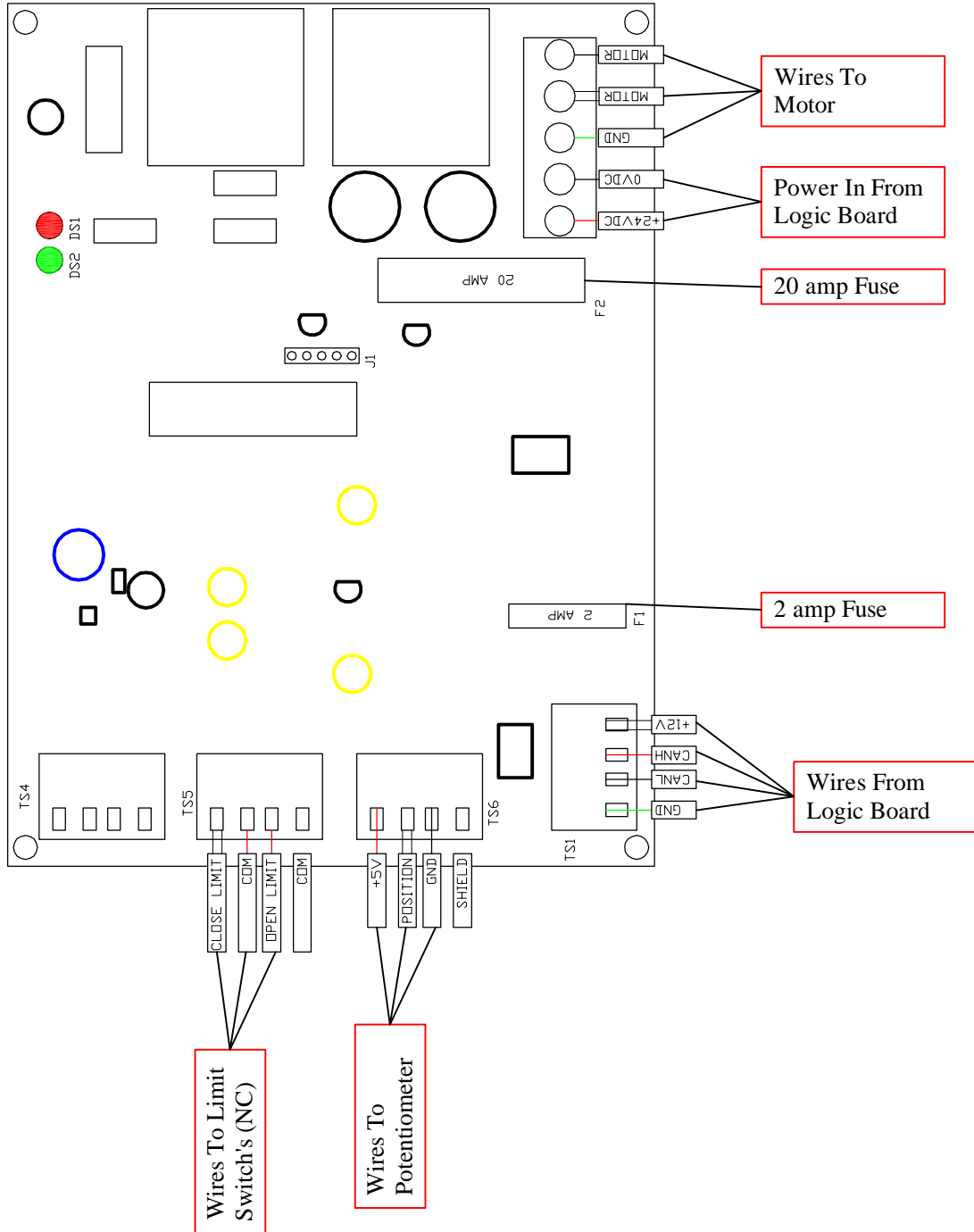

**TILT-A-WAY  
DCM  
BASIC ELECTRICAL HARDWARE  
DRAWING DCM E-204 ON PAGE 9 SINGLE GATE  
DRAWING DCM E-205 ON PAGE 10 MASTER GATE**

REF	PART NO.	DESCRIPTION	QTY
1	P00558	ENCLOSURE	1
2	PEO602	CIRCUIT BREAKER	1
3	PEO202I	INTERFACE BOARD	1
4	PEO202L	LOGIC BOARD	1
5	PEO202G	MOTOR BOARD	1
6	PEO202C	CONNECTING CORD	1
7	PEO504	SAFETY SWITCH	1 OR 2
8	PEO500	LIMIT SWITCH (nc)	2
9	PEO502	POTENTIOMETER	1
10	PEO223	½" ROMEX	3
11	PEO275	¾" ROMEX	2
12	100127	ALARM	1
	100127A	BASE (not shown)	1
13	PEO664A	BATTERY CHARGER (dual bank)	1
14	PEO605A	RELAY SOCKET 5 PIN	1
15	PEO679	RELAY 5 PIN SAFETY	1
16	PEO620	END BARRIER (not shown)	1
17	PEO621	G TERMINAL BLOCK	1
18	PEO624	N TERMINAL BLOCK	1
19	PEO622	L1 TERMINAL BLOCK	1
20	PEO665	RADIO RECEIVER (optional not shown)	1
21	PEO663	RADIO TRANSMITTER (optional not shown)	as req.
22	PEO605A	RELAY SOCKET 5 PIN (optional for alarm)	1
23	PEO679	RELAY 5 PIN (optional for alarm)	1

**DRAWING DCM E-206 ON PAGE 11 SLAVE GATE**

REF	PART NO.	DESCRIPTION	QTY
1	PEO292	ENCLOSURE	1
2	PEO602	CIRCUIT BREAKER	1
5	PEO202G	MOTOR BOARD	1
7	PEO501	SAFETY SWITCH	1 OR 2
8	PEO500	LIMIT SWITCH (nc)	2
10	PEO223	½" ROMEX	3
11	PEO275	¾" ROMEX	2
13	PEO664A	BATTERY CHARGER (dual bank)	1
14	PEO605A	RELAY SOCKET 5 PIN	1
15	PEO679	RELAY 5 PIN SAFETY	1
16	PEO620	END BARRIER (not shown)	1
17	PEO621	G TERMINAL BLOCK	1
18	PEO624	N TERMINAL BLOCK	1
19	PEO622	L1 TERMINAL BLOCK	1

# TILT-A-WAY DCM SINGLE GATE

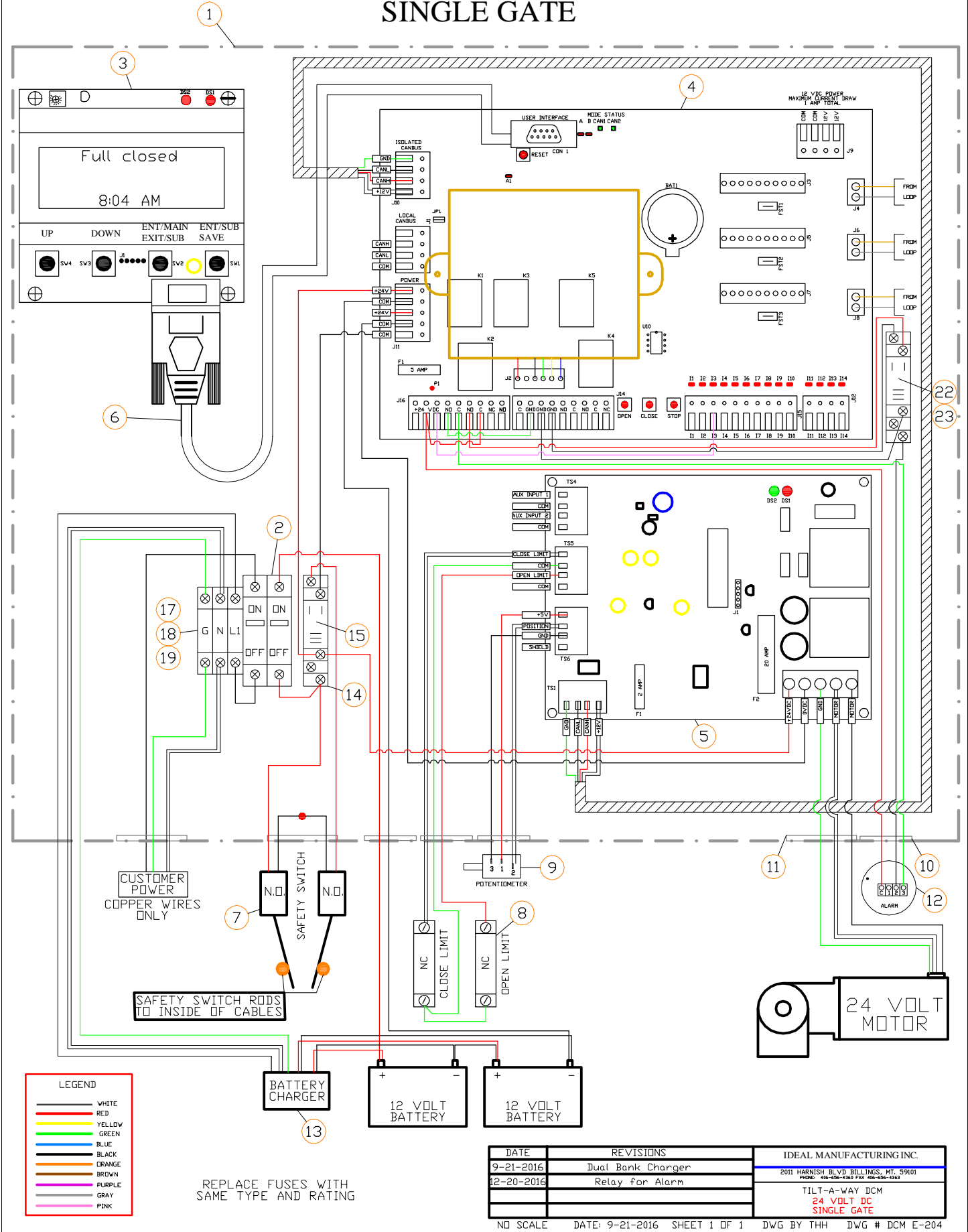

**LEGEND**

- WHITE
- RED
- YELLOW
- GREEN
- BLUE
- BLACK
- ORANGE
- BROWN
- PURPLE
- GRAY
- PINK

REPLACE FUSES WITH  
SAME TYPE AND RATING

DATE	REVISIONS	IDEAL MANUFACTURING INC.
9-21-2016	Dual Bank Charger	2011 HARNISH BLVD BILLINGS, MT, 59101 PHONE: 406-656-4365 FAX: 406-656-4363
12-20-2016	Relay for Alarm	TILT-A-WAY DCM 24 VOLT DC SINGLE GATE

# TILT-A-WAY DCM MASTER GATE

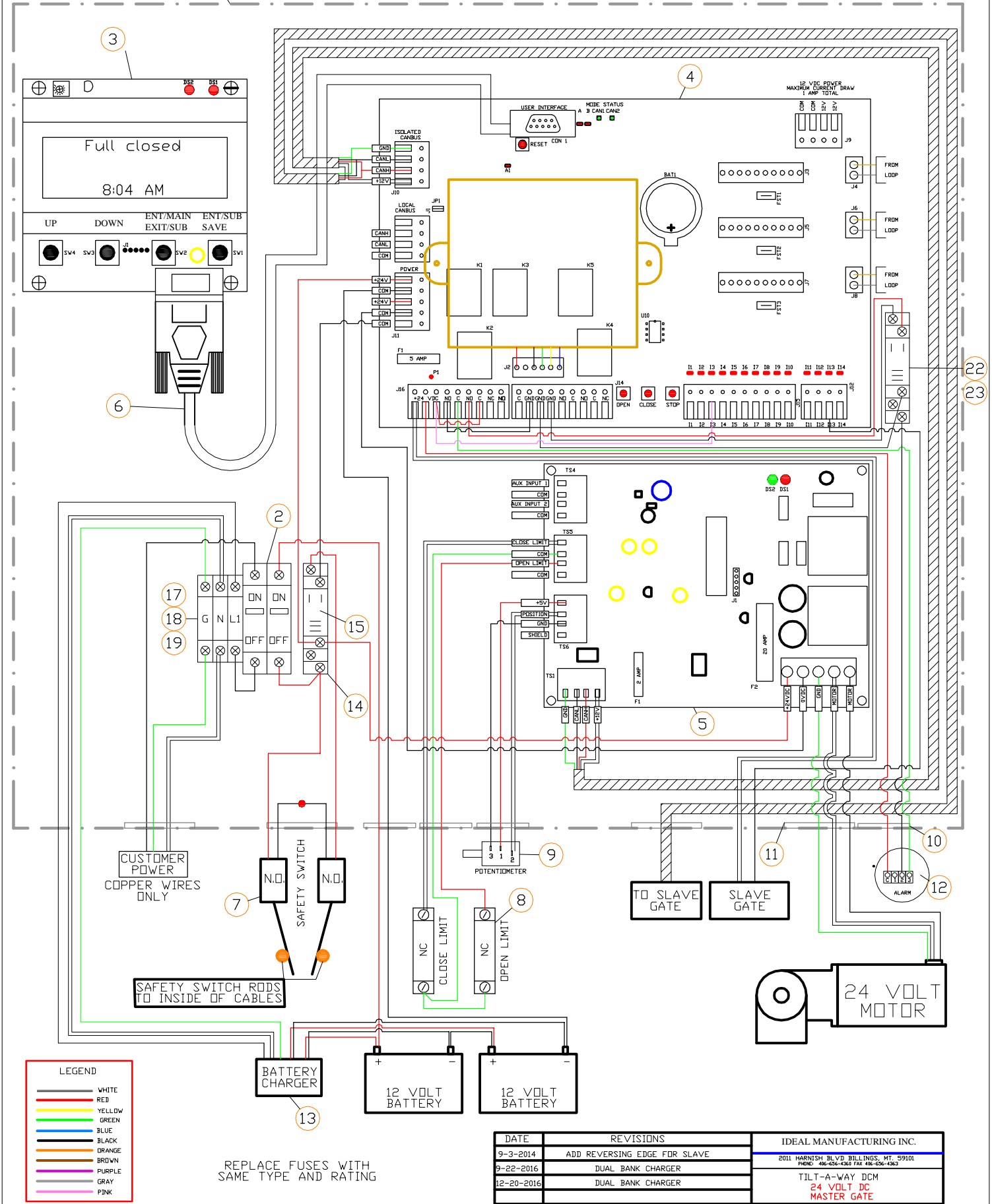

**LEGEND**

- WHITE
- RED
- YELLOW
- GREEN
- BLUE
- BLACK
- ORANGE
- BROWN
- PURPLE
- GRAY
- PINK

REPLACE FUSES WITH SAME TYPE AND RATING

DATE	REVISIONS	IDEAL MANUFACTURING INC.
9-3-2014	ADD REVERSING EDGE FOR SLAVE	2011 HARNISH BLVD BILLINGS, MT, 59101
9-22-2016	DUAL BANK CHARGER	PHONE: 406-656-4363 FAX 406-656-4363
12-20-2016	DUAL BANK CHARGER	TILT-A-WAY DCM 24 VOLT DC MASTER GATE

# TILT-A-WAY DCM SLAVE GATE

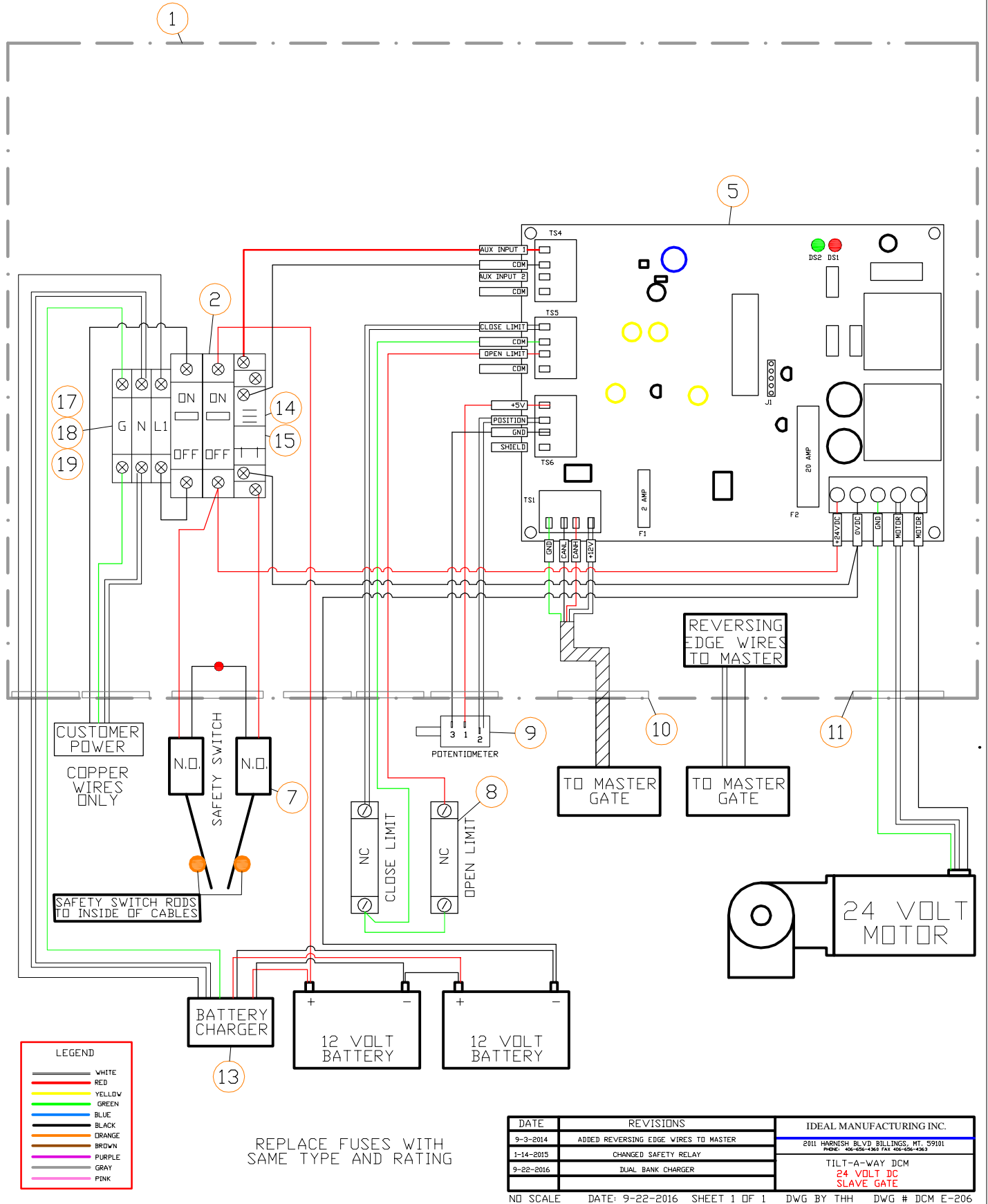



**TILT-A-WAY  
OPERATOR FIELD INSTALLATION  
DRAWING # DCM-1002  
TILT-A-WAY DCM**

**Note: The gate must be installed in a location so that enough clearance is supplied between the gate and adjacent structures when opening and closing to reduce the risk of entrapment. Check for overhead obstructions. The latches on the access doors for the control box must be locked. After the gate is installed check the gate balance. If the gate is not balanced see page 14 for instructions.**

- 1 Control pedestal **DCM**.  
Concrete support slab. Minimum dimensions 90" long x 48" wide x 18" thick.  
To be placed on firm soil or compacted fill, reinforced with #4 rebar each way; and cement piling 12" diameter dug to frost line by purchaser  
NOTE: Will withstand and estimated 100 MPH wind in most soil conditions.
- 2 Electrical conduit area. Stub in electrical supply, 15 Amp service.
- 3 Four anchor bolts 3/4" diameter with 1 1/2" projection. Set in slab or expansion type.
- 4 Place pedestal attachment plate holes on 3/4" bolts in concrete support slab with exact alignment and secure with washers and nuts. If expansion type bolts are used place pedestal on concrete support slab with exact alignment. Drill 3/4" hole in concrete thru hole in attachment plates to needed depth. Recheck alignment place expansion bolts in drilled holes and secure with washers and nuts.
- 5 The gate must be properly installed and work freely in both directions prior to the installation of the gate operator. Do not increase the operator amperage levels beyond the required operable amounts to compensate for a damaged gate.
- 6 Determine the best level of open and close force for the installation. An improper level will defeat the inherent current sensing purpose and make the installation unsafe. By utilizing the "Motor Current" feature; proper and accurate levels can be obtained when adjusting the open and close force settings. Improper testing and setting of the force adjustment can increase the risk of serious injury or death.

**INSTALLATION PROCEDURE FOR GATE THAT IS SHIPPED  
UNASSEMBLED DRAWING # DCM-1002**

1. Remove all materials used for protection during shipment.
2. Place pedestal over the anchor bolts of prepared foundation. Align and level pedestal, secure with washers and nuts. Remove lifting hook.
3. Remove large side covers, and access door to expose spring tension adjustment screws.
4. Install recommended size battery, and connect leads from electrical box. See wiring diagram page 9 in owner's manual.
5. Back off spring tension screws to provide slack in tension cables. (1 5/8" socket needed)
6. Install barrier and secure to vertical carriage post with bolt, and nut. Bolt and nut at outer end of carriage horizontal channel.
7. Tighten spring tension screws while inspecting cables for proper wrap around balance sheaves. When slide members have reached marks indicated on tracks. Proper balance tension will have been achieved. If at a later date minor adjustment should be required, refer to balance system-adjusting section.
8. Perform required electrical connections in accordance with diagrams shown in this manual.
9. Reinstall large side covers, and access door. Close and secure access door.
10. If gate fails to function properly, contact manufacturer's representative.

**INSTALLATION PROCEDURE FOR GATE THAT IS SHIPPED ASSEMBLED DRAWING # DCM-1002**

1. Remove all materials used for protection during shipment.
2. Place pedestal and barrier over the anchor bolts of prepared foundation. Align and level pedestal, secure with washers and nuts. Remove lifting hook.
3. Install recommended size battery, and connect leads from electrical box.
4. Perform required electrical connections in accordance with diagrams shown in this manual.
5. Turn power switch on. Close and secure access door.
6. If gate fails to function properly, contact manufacturer's representative.

TILT-A-WAY  
 VERTICAL PIVOT GATE DCM  
 OPERATOR FIELD INSTALLATION  
 RIGHT HAND OPERATOR SHOWN  
 LEFT HAND OPPOSITE

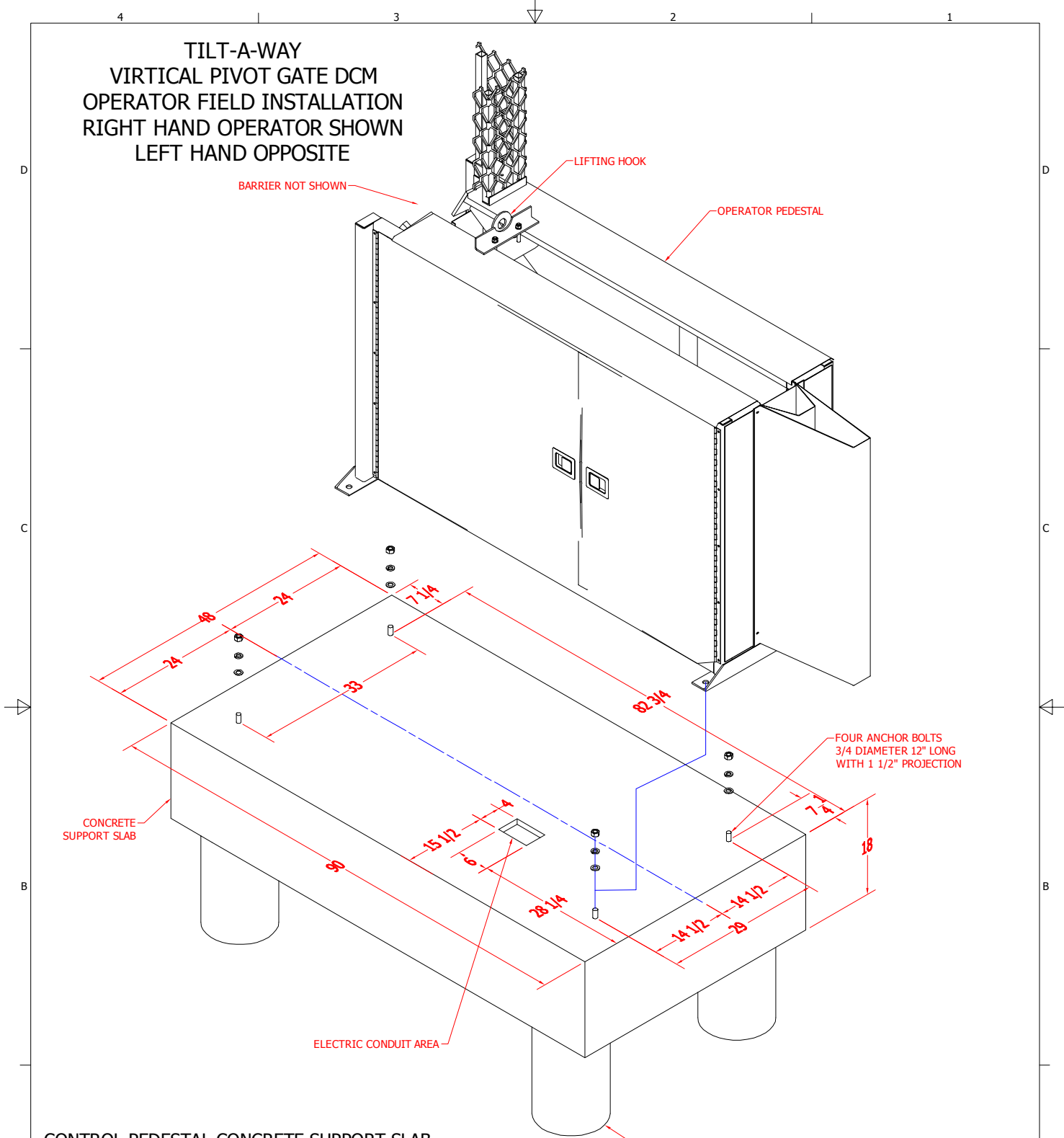

CONTROL PEDESTAL CONCRETE SUPPORT SLAB  
 DIMENSIONS 90" LONG X 48" WIDE X 18" DEEP MINIMUM  
 STUB IN ELECTRICAL SUPPLY, 15 AMP SERVICE IN  
 ELECTRIC CONDUIT AREA  
 ALIGN AND LEVEL CONTROL PEDESTAL WITH GROUT  
 AND BOLT IN PLACE  
 TO BE PLACED ON FIRM SOIL OR COMPACTED FILL  
 REINFORCE WITH #4 REBAR EACH WAY  
 CONCRETE PILINGS DUG TO FROST LINE BY PURCHASER  
 NOTE: WILL WITHSTAND AN ESTEMATED 100 MPH WIND  
 IN MOST SIOL CONDITIONS

DRAWN THenry	10/15/2013	<b>IDEAL MFG., INC.</b> 2011 Harnish Blvd. Billings MT 59101 Tel. (406) 656-4360	
CHECKED	10/15/2013		
QA		TITLE	
MFG		DCM FIELDS INSTALLATION	
APPROVED		SIZE C	DWG NO DCM-1002
		SCALE	REV
		SHEET 1 OF 1	

**TILT-A-WAY DCM  
OPERATOR BALANCE SYSTEM ADJUSTMENT  
DRAWING # DCM-1003**

**TILT-A-WAY road gate must be balanced to offer the least amount of resistance against movement at both up and down extreme positions or combination of both.**

**Balance adjustment is accomplished by cable tension, cable sheave position or combination of both.**

**One or two cable systems are incorporated and any adjustments performed at one side must be duplicated on the opposite side if two cable systems are used.**

**Instruction procedure for replacing cables, or springs are on page 30.**

**SAFETY WARNINGS-VERY IMPORTANT**

- 1. Before performing any maintenance or adjustment, turn power switch to off located inside of the control panel enclosure, and disconnect the battery. Prior to performing any adjustment, remove the carriage linkage pin (see page 19).**
- 2. Any adjustment performed on cable sheave must be preceded by the release of all cable tension at spring connections.**

**CONDITIONS AND SOLUTIONS**

- 1. Condition: Gate heavy at both up and down positions.  
Solution: Increases cable tension.**
- 2. Condition: Gate light at both up and down positions  
Solution: Decrease cable tension.**
- 3. Condition: Gate heavy at down position only.  
Solution: Lower cable sheave and increase cable tension.**
- 4. Condition: Gate light at down position only.  
Solution: Raise cable sheave and decrease cable tension.**
- 5. Condition: Gate heavy at up position only.  
Solution: Raise cable sheave and decrease cable tension.**
- 6. Condition: Gate light at up position only.  
Solution: Lower cable sheave increase cable tension.**
- 7. Condition: Gate heavy at intermediate positions.  
Solution: Move cable sheave forward.**
- 8. Condition: Gate light at intermediate positions.  
Solution: Move cable sheave rearward.**

# TILT-A-WAY DCM BALANCE SYSTEM ADJUSTMENT

GATE UP

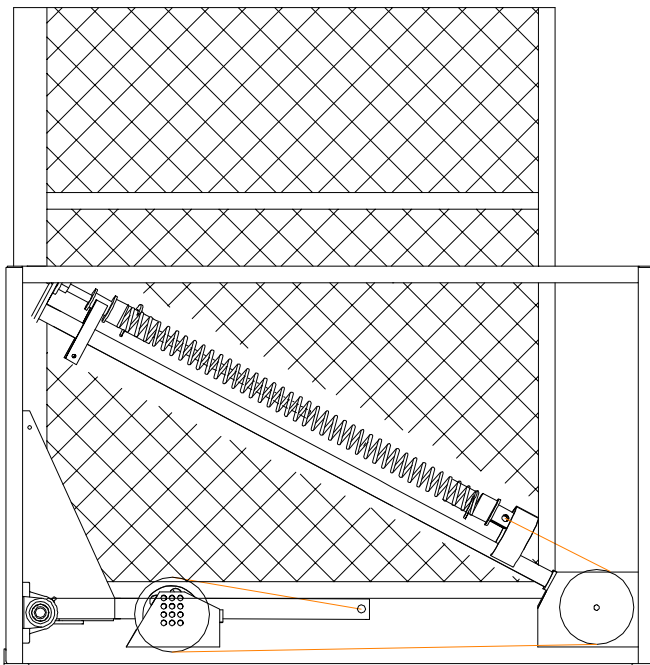

GATE DOWN

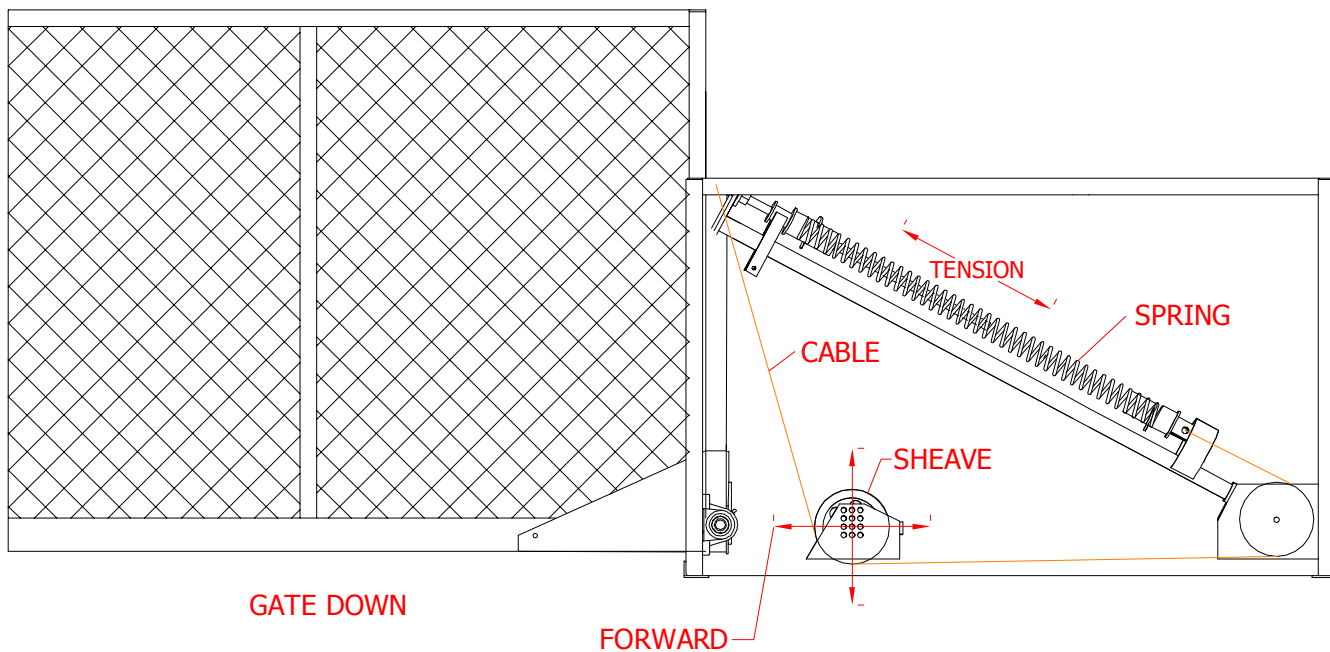

DRAWN	THenry	2/17/2014	<b>IDEAL MFG., INC.</b>	
CHECKED		10/15/2013	TITLE	
QA			BALANCE SYSTEM ADJUSTMENT	
MFG		2/17/2014	REV	
APPROVED			SIZE	DWG NO
			C	DCM-1003
			SCALE	SHEET 1 OF 1

**TILT-A-WAY DCM  
OPERATOR GENERAL ARRANGEMENT and  
RECOMMENDED GENERAL MAINTENANCE  
DCM-1004**

<b>REF NO.</b>	<b>DESCRIPTION</b>	
<b>1</b>	Control Pedestal Frame	For Covering. See Drawing DCM-1005 Page 25
<b>2</b>	Barrier Unit (not shown)	See Drawing DCM-1006 Page 22
<b>3</b>	Gear Motor Unit	See Drawing DCM-1007 Page 21
<b>4</b>	Electrical Control Enclosure	See Drawing DCM E-204 Page 9
<b>5</b>	Barrier Carriage	See Drawing DCM-1008 Page 19
<b>6</b>	Balance System Front Sheave	See Drawing DCM-1009 Page 23
<b>7</b>	Balance System Rear Sheave	See Drawing DCM-1010 Page 24
<b>8</b>	Balance System Tension Cable	See Drawing DCM-1011 Pages 26, 27
<b>9</b>	Balance System Tension Spring	See Drawing DCM-1011 Pages 26, 27
<b>10</b>	Balance System Spring Tension Adjusting Limit	See Drawing DCM-1011 Page 27
<b>11</b>	Balance System Spring Tension Release	Power Off Safety Switch. See Drawing DCM-1010 Page 24
<b>12</b>	Actuating Sprocket	See Drawing DCM-1012 Page 29
<b>13</b>	Actuating Limit Switch System	See Drawing DCM-1012 Page 29
<b>14</b>	Battery Charger Dual Bank	See Drawing DCM-1004 Page 17
<b>15</b>	12 Volt Battery	See Drawing DCM-1004 Page 17
<b>16</b>	Pivot Pin	See Drawing DCM-1008 Page 19
<b>17</b>	Potentiometer Sprocket	See Drawing DCM-1012 Page 29

**Note: Turn all power off before performing maintenance.**

Check interior of pedestal for any accumulation of trash caused by blowing wind and remove.

On regular basis the following maintenance steps should be performed (**Monthly**).

1. Check gear motor reducer for oil leaks. Gear reducer uses 4 ½ ounces of Dextron #2 hydraulic fluid (same as automatic transmission fluid).
2. Clean and lubricate spring tension screws with (general purpose grease) to prevent rusting.
3. Lubricate with (general purpose #2 grease) all points equipped with zerk fitting.
  - A. Barrier carriage pivot bearings. (2)
  - B. Actuating sprocket bearings. (2)
  - C. Carriage pivot linkage (sprocket end).
  - D. Inspect and clean chain (not shown). Check chain tension it should be reasonably tight.
4. Inspect balance cables for broken strands. Replace cable if there are five broken strands per lay or ten broken strands over all. See page 30 for instructions.
5. Check gate balance by removing hairpin, and pivot pin on carriage (see page 19). Raise gate to mid position. Gate should remain stationary when you let go of barrier. If the gate moves in either direction see page 14 for adjustments.
6. It is important that the fluid level of any connected batteries be checked on a regular basis. All batteries will (gas) and lose some fluids when continuously connected to any charging source.

TILT-A-WAY  
 VERTICAL PIVOT GATE DCM  
 OPERATOR GENERAL ARRANGEMENT  
 RIGHT HAND OPERATOR SHOWN  
 LEFT HAND OPPOSITE

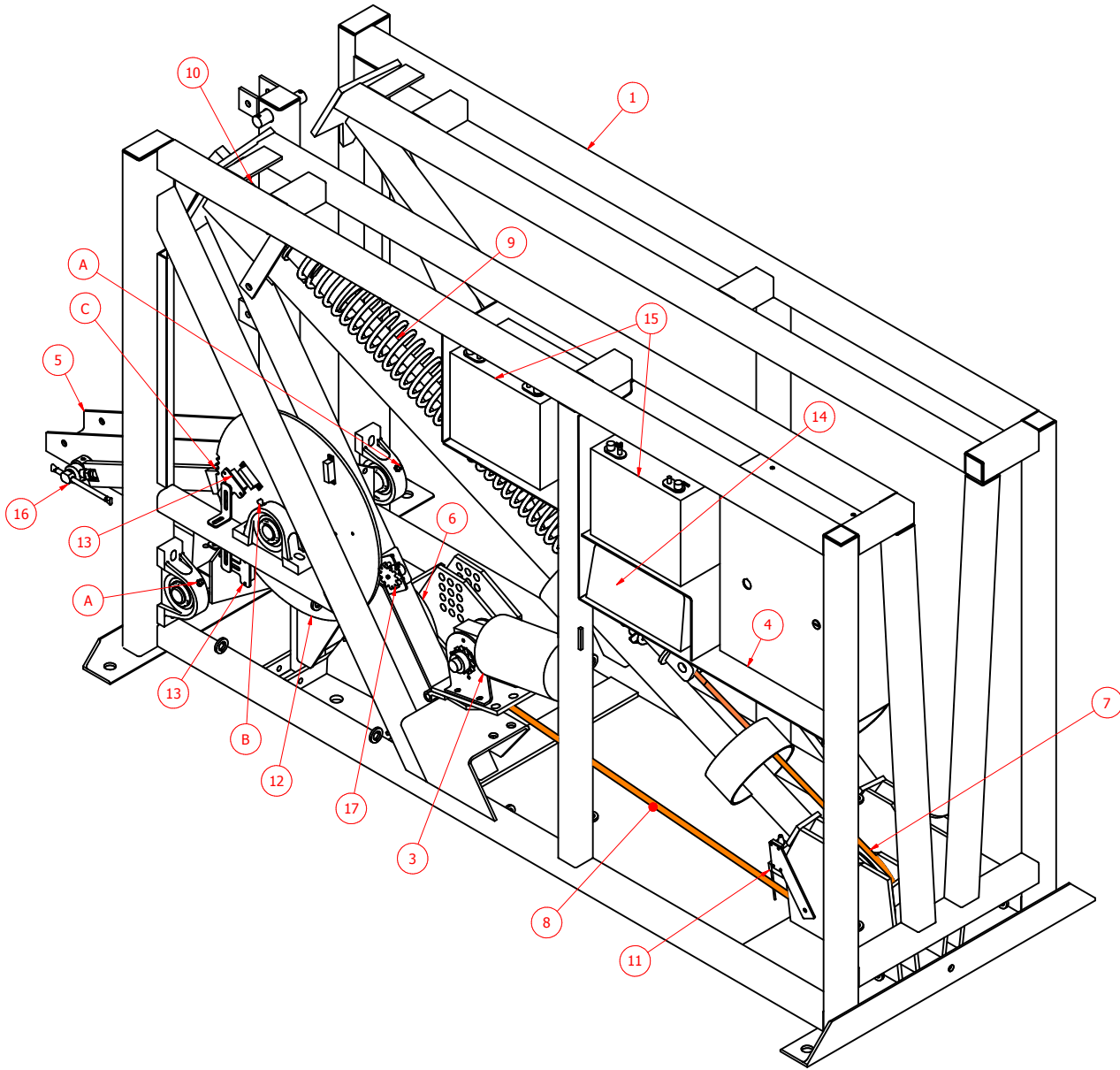

DRAWN	10/22/2013	<b>IDEAL MFG., INC.</b>	
CHECKED	2/17/2014	2011 Harnish Blvd.	Billings MT 59101 Tel. (406) 656-4360
QA		TITLE	
MFG		TILT-A-WAY DCM GENERAL ARRANGEMENT	
APPROVED		SIZE	DWG NO
		C	DCM-1004
		SCALE	REV
			SHEET 1 OF 1

## TILT-A-WAY DCM BARRIER CARRIAGE

### DRAWING DCM-1008

REF NO.	PART NO.	DESCRIPTION	REQ'D NO.
1	N/A	3/8" X 1 1/4" Hex Bolt	2
2	N/A	3/8" Flat Washer	2
3	N/A	3/8" Lock Washer	2
4	N/A	3/8" Hex Nut	2
5	N/A	1/2" x 3 1/4" Hex Bolt	2
6	N/A	1/2" X 4 1/2" Hex Bolt	8
7	N/A	1/2" X 5" Hex Bolt	1
8	N/A	1/2" SAE Flat Washer	8
9	N/A	1/2" Lock washer	8
10	N/A	1/2" Hex Nut	8
11	N/A	1/2" Nylock Nut	4
12	N/A	5/8" – 18 Hex Jam Nut	1
13	N/A	1" SAE Flat Washer	2
14	N/A	5/8 – 11 X 2 Socket Head Cap Screw	1
ID1006	ID1006	3/16" X 1 1/2" Stainless Cotter Pin	2
FGO408	FGO408	Carriage Pivot Linkage	1
FGO409A	FGO409A	Barrier Carriage Frame	1
FGO410B	FGO410B	Pivot Pin Threaded 5/8-11	1
FGO411	FGO411	Pivot Arm	1
FGO633	FGO633	Stop Plate	1
FGO635	FGO635	3/8 Key	1
POO770	POO770	Hair Pin	1
TWO101	TWO101	Pillow Block Bearing	4
TWO313	TWO313	Linkage end	1
TWO420	TWO420	Sprocket	1
TWO429M	TWO429M	Shoulder Bolt	1

TILT-A-WAY  
 VERTICAL PIVOT GATE DCM  
 BARRIER CARRIAGE  
 RIGHT HAND CARRIAGE SHOWN  
 LEFT HAND CARRIAGE OPPOSITE

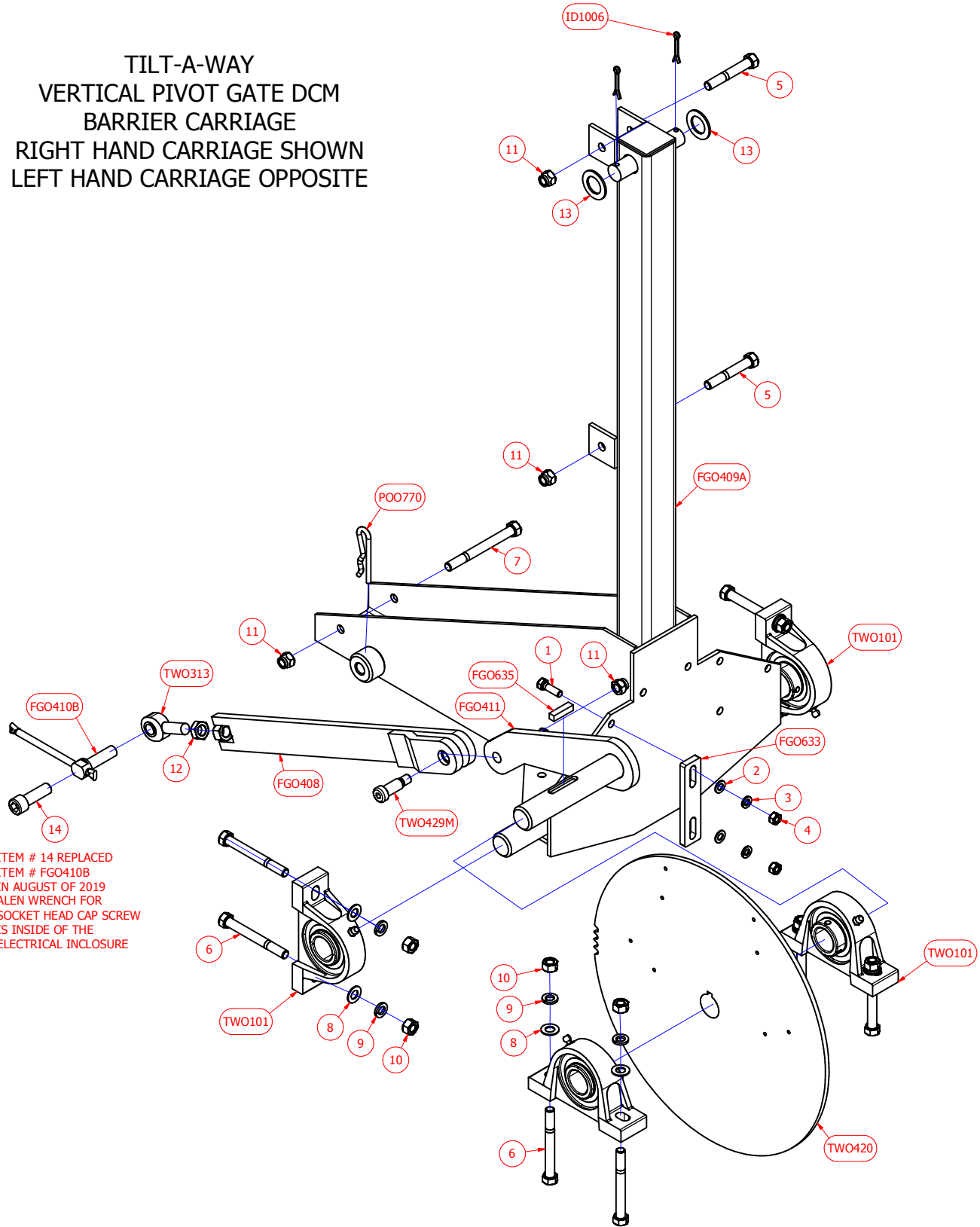

ITEM # 14 REPLACED  
 ITEM # FGO410B  
 IN AUGUST OF 2019  
 ALLEN WRENCH FOR  
 SOCKET HEAD CAP SCREW  
 IS INSIDE OF THE  
 ELECTRICAL INCLOSURE

DRAWN	THenry	10/16/2013	<b>IDEAL MFG., INC.</b> 2011 Harnish Blvd. Billings MT 59101 Tel. (406) 656-4360	
CHECKED		2/17/2014		
QA			TITLE	
MFG			TILT-A-WAY DCM BARRIER CARRIAGE	
APPROVED			SIZE	DWG NO
			C	DCM-1008
			SCALE	REV
				1
			SHEET 1 OF 1	

REVISION HISTORY			
REV	DESCRIPTION	DATE	APPROVED
1	REPLACED FGO410B WITH 5/8 - 11 X 2 SOCKET HEAD CAP SCREW	8/19/2019	P MOON



**TILT-A-WAY DCM  
GEAR MOTOR WITH COMPONENTS  
DCM-1007**

<b>REF NO.</b>	<b>PART NO.</b>	<b>DESCRIPTION</b>	<b>REQ'D NO.</b>
1	N/A	1/4 KEY	1
2	N/A	3/8 x 1 1/4 Hex Bolt	4
3	N/A	3/8 Lock Washer	4
4	N/A	3/8 Hex Nut	4
5	N/A	1/2-20 All Thread	2
POO120D	POO120D	1/2-20 Lug Nut	8
TWO422	TWO422	Lock Collar	1
TWO423	TWO423	# 40 Roller Chain (not shown)	1
TWO424	TWO424	# 40 Connector Link	1
TWO451	TWO451	Drive Sprocket	1
TWO432	TWO432	Gear Motor Unit (24-vdc)	1

TILT-A-WAY DCM  
GEAR MOTOR AND COMPONENTS

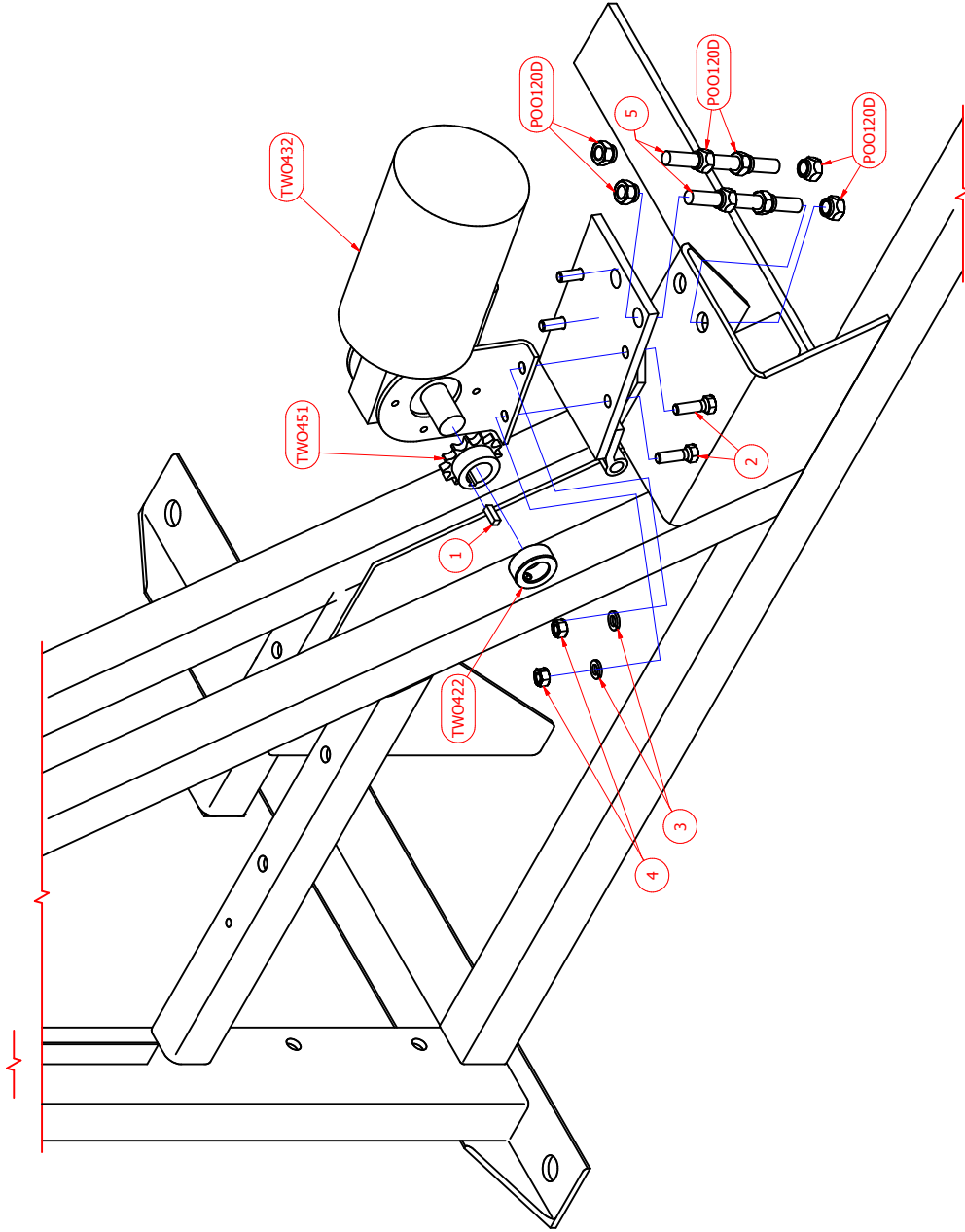

DRAWN	10/16/2013
THENRY	
CHECKED	2/17/2014
QA	
MFG	
APPROVED	
SIZE	C
DWG NO	DCM-1007
REV	

IDEAL MFG., INC.  
2011 Harnish Blvd.  
Billings MT 59101  
Tel. (406) 656-4360

TILT-A-WAY DCM GEAR MOTOR

# TILT-A-WAY DCM BARRIER UNIT

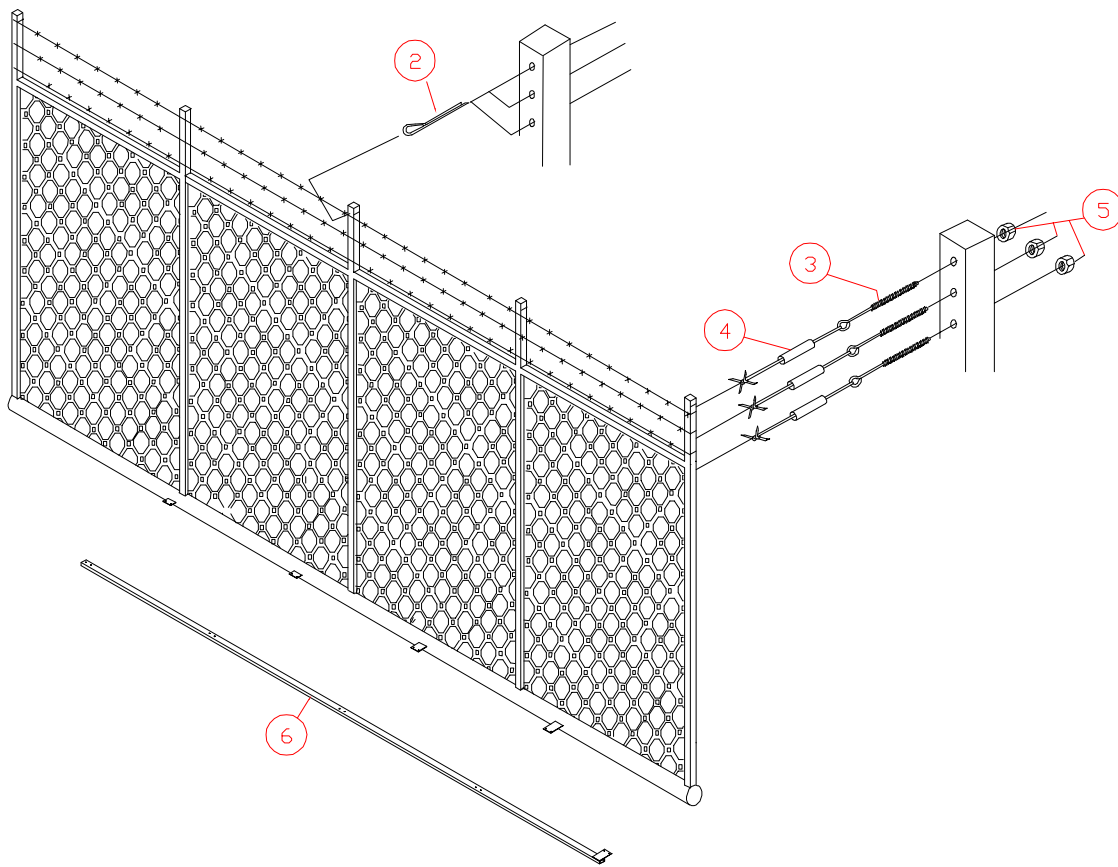

REF NO.	PART NO.	DESCRIPTION	REQ NO
1		Barrier serial # decal located on electrical enclosure	
		Barrier assemblies are manufactured from steel or aluminum material and varied in lengths and heights.	
		When contacting manufacturer regarding a TILT-A-Way gate, always provide complete serial number.	
2	ID1066	3/16" x 2 1/2 Stainless Steel Cotter Pin - 3 per inside tube	
3	ID1063	5/16 x 4" Eye Bolts (3 per end)	6
4	ID1064	Wire Crimp	6
5	N/A	5/16" Hex Nut	6
6	G00121 G00122	Right Hand Sway Brace left Hand Sway Brace	1
7	N/A	1/4 x 1 1/2 Hex Bolts, Lock Washer, and Nut	6
			8

DRAWN THenry	10/16/2013	<b>IDEAL MFG., INC.</b>		
CHECKED	3/22/2016			
QA		TITLE		
MFG		TILT-A-WAY DCM BARRIER UNIT		
APPROVED		SIZE C	DWG NO DCM-1006	REV
		SCALE		SHEET 1 OF 1

# TILT-A-WAY DCM BALANCE SYSTEM FRONT SHEAVE

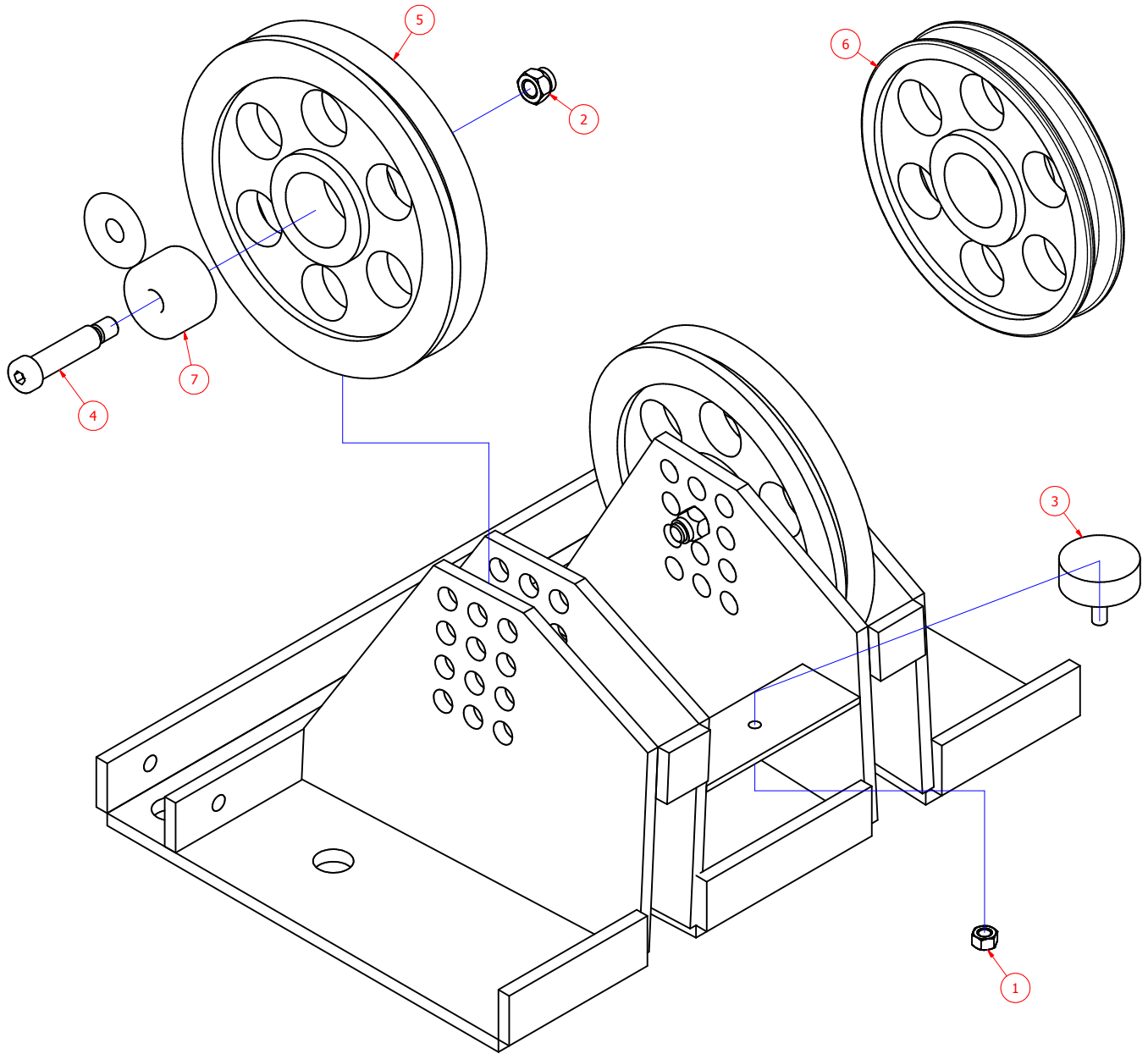

ITEM	PART NUMBER	DESCRIPTION	QTY
1	N/A	HEX NUT 3/8	1
2	N/A	NYLOCK HEX NUT 1/2	1 PER SHEAVE
3	PEO940	BUMP STOP	1
4	TWO103	SHOULDER BOLT	1 PER SHEAVE
5	TWO105	CABLE SHEAVE WITH BEARING	1 PER SPRING
6	TWO105-1	CABLE SHEAVE (PINK COLORED ONLY) WITH BEARING	1 PER SPRING
7	TWO106	SHEAVE BEARING	1 PER SHEAVE
8	TWO110-6	TENSION CABLE 120 1/2" (NOT SHOWN)	1 PER SHEAVE

DRAWN THenry	10/16/2013	<b>IDEAL MFG., INC.</b>	
CHECKED	2/17/2014	2011 Harnish Blvd. Billings MT 59101 Tel. (406) 656-4360	
QA		TITLE	
MFG		TILT-A-WAY DCM FRONT SHEAVE PLATE	
APPROVED		SIZE C	DWG NO DCM-1009
		SCALE	REV
			SHEET 1 OF 1

# TILT-A-WAY DCM BALANCE SYSTEM REAR SHEAVE

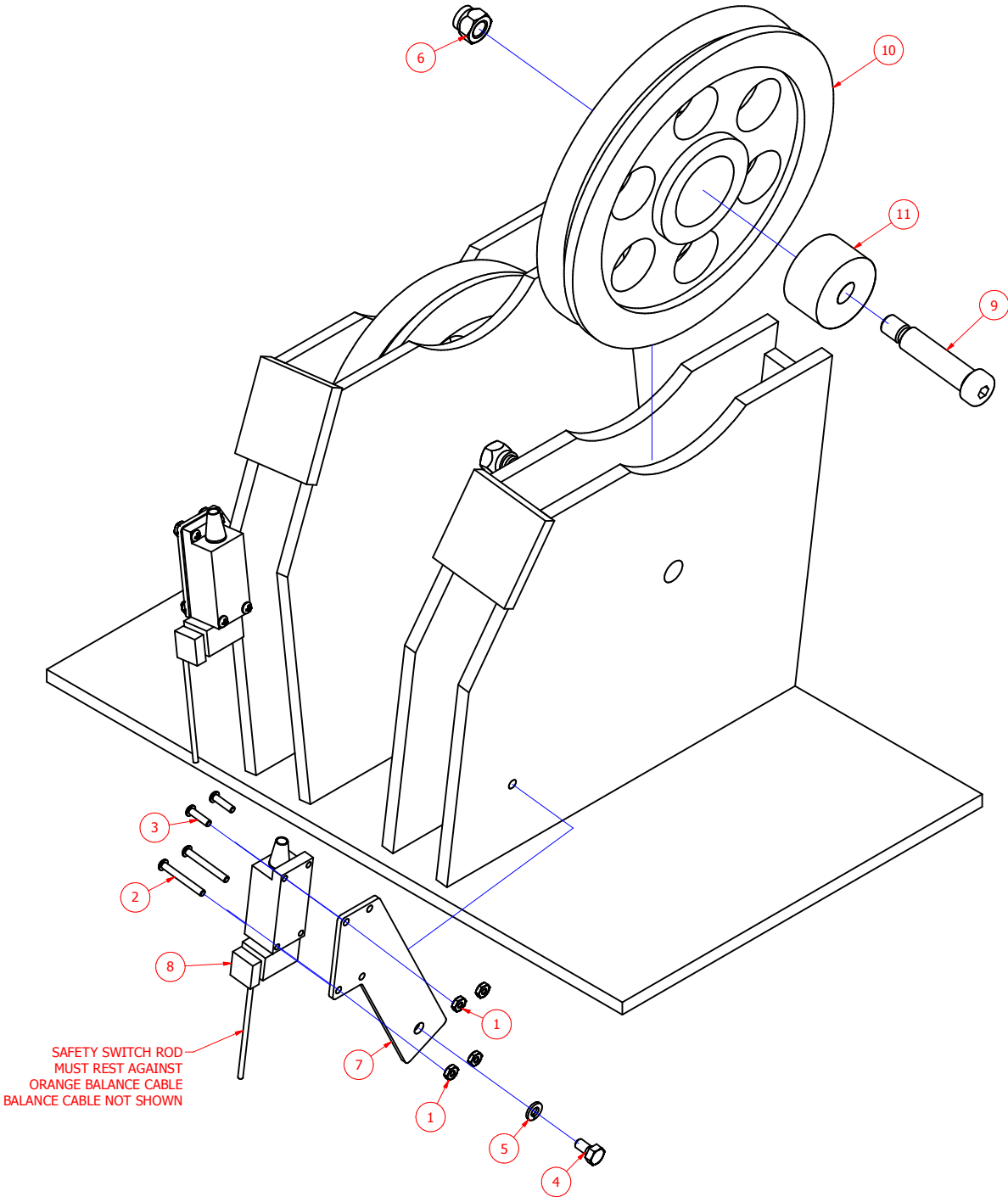

Parts List			
ITEM	PART NUMBER	DESCRIPTION	QTY
1	N/A	HEX NUT #8	4 PER SHEAVE
2	N/A	MACHINE SCREW 8-32 X 1 3/8	2 PER SHEAVE
3	N/A	MACHINE SCREW 8-32 X 3/4	2 PER SHEAVE
4	N/A	HEX BOLT 1/4 X 1/2	1 PER SHEAVE
5	N/A	LOCK WASHER 1/4	1 PER SHEAVE
6	N/A	NYLOCK HEX NUT	1 PER SHEAVE
7	FGO412	SAFETY SWITCH BRACKET	1 PER SHEAVE
8	PEO501	SAFETY LIMIT SWITCH	1 PER SHEAVE
9	TWO103	SHOULDER BOLT	1 PER SHEAVE
10	TWO105	CABLE SHEAVE WITH BEARING	1 PER CABLE
11	TWO106	SHEAVE BEARING	1 PER SHEAVE

DRAWN THenry	10/17/2013	<b>IDEAL MFG., INC.</b>	
CHECKED	2/17/2014	2011 Harmish Blvd. Billings MT 59101 Tel. (406) 656-4360	
QA		TITLE	
MFG		TILT-A-WAY DCM REAR SHEAVE PLATE	
APPROVED		SIZE C	DWG NO DCM-1010
		SCALE	REV
			SHEET 1 OF 1

# TILT-A-WAY DCM COVERS AND GUARDS

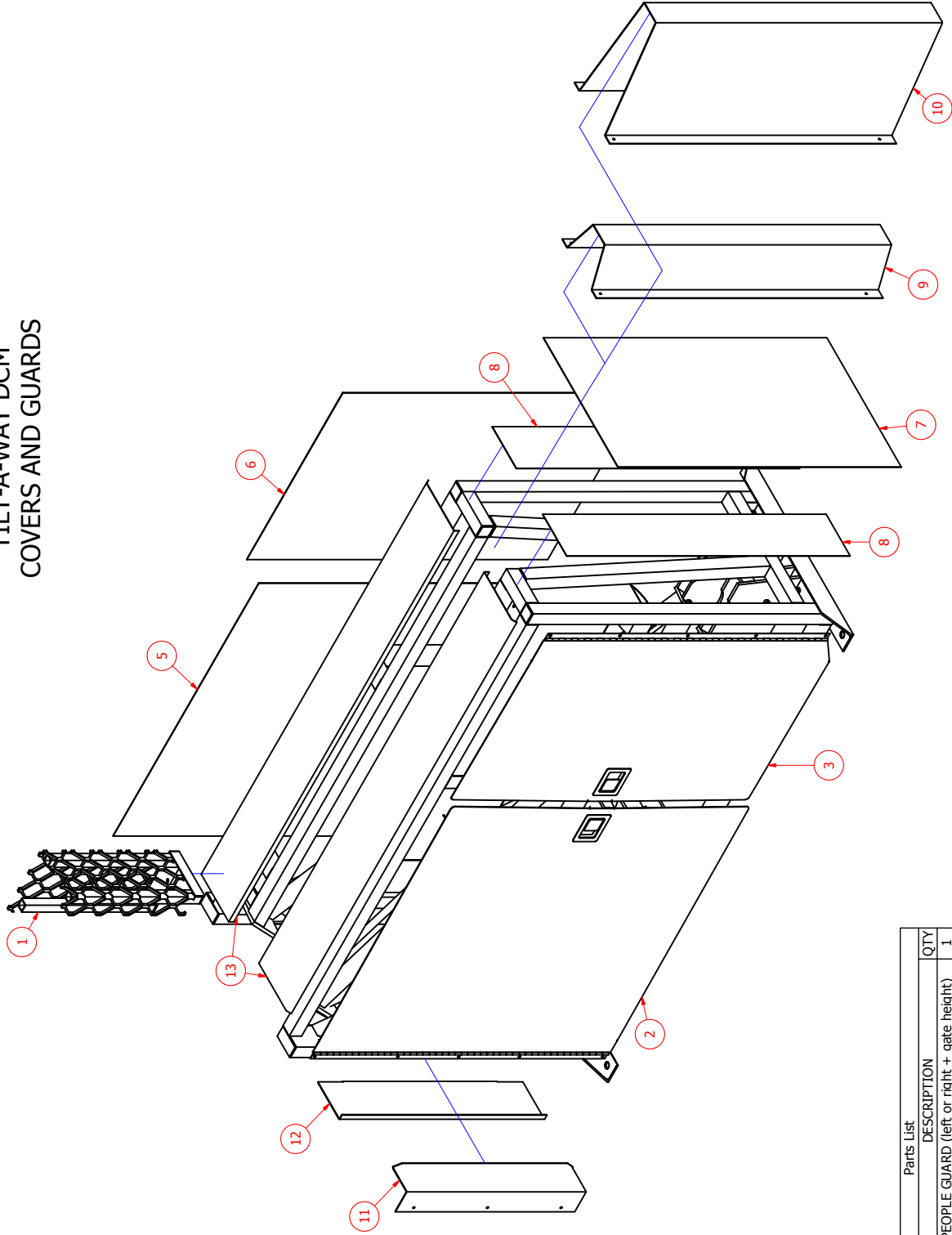

ITE	PART NUMBE	DESCRIPTION	QTY
1	FGO175	PEOPLE GUARD (left or right + gate height)	1
2	FGO619	SPRING ACCESS DOOR	1
3	FGO620R	ELECTRICAL ACCESS DOOR RIGHT HAND	1
	FGO620L	ELECTRICAL ACCESS DOOR LEFT HAND	
5	FGO621	LARGE SIDE COVER	1
6	FGO623	SMALL SIDE COVER	1
7	FGO624	REAR COVER (6' tall or shorter gate)	1
8	FGO625	REAR COVER (7' and taller gate)	2
9	FGO626	REAR GUARD (7' tall gate)	1
10	FGO627	REAR GUARD (8' tall gate)	1
11	FGO628	FRONT SPROCKET GUARD	1
12	FGO630M	FRONT GUARD	1
13	FGO631	TOP COVER	2

Parts List

DRAWN	10/17/2013	<b>IDEAL MFG., INC.</b>	
THENNY		2011 Harnish Blvd. Billings MT 59101 Tel. (406) 656-4360	
CHECKED	4/29/2015	TITLE	
QA		TILT-A-WAY DCM COVERS AND GUARDS	
MFG		SIZE	DCM-1005
APPROVED		SCALE	
		REV	

**TILT-A-WAY DCM  
BALANCE SYSTEM SPRING TENSIONER UNIT  
DCM-1011  
1 or 2 ASSEMBLIES INCLUDED CHECK INSIDE OF  
PEDESTAL FRAME FOR QUANTITY**

<b>REF NO.</b>	<b>PART NO.</b>	<b>DESCRIPTION</b>	<b>REQ'D NO.</b>
	N/A	Pedestal Frame (not shown)	
2	FGO412	Safety Device Bracket (See Page 24)	
3		Tension Spring	
	TWO137	500 Pound (Blue)	1 or 2
	TWO138	1000 Pound (Yellow)	1 or 2
	TWO139	1500 Pound (Orange)	1 or 2
	TWO112	1750 Pound (Green)	1 or 2
	TWO140	2000 Pound (Red)	1 or 2
	TWO113	2500 Pound (White)	1 or 2
4		Lower Spring Connector	
	FGO168	500 or 1000 Pound Spring	1 or 2
	FGO170	1500 or 1750 Pound Spring	1 or 2
	FGO171	2000 or 2500 Pound Spring	1 or 2
5	TWO104	Clevis Pin	1 or 2
6		Upper Spring Connector	
	FGO139	500 or 1000 Pound Spring	1 or 2
	FGO157	1500 or 1750 Pound Spring	1 or 2
	FGO159	2000 or 2500 Pound Spring	1 or 2
7	TWO155	Threaded Bronze Hex Stock Encased in Item 6	1 or 2
8	FGO130	Tension Screw with End Nut Welded	1 or 2
9	FG0632	Thrust Washer	1 or 2
10	FGO131	Safety Nut	2 or 4
11	N/A	1ö SAE Washer	2 or 4
12	ID1061	Cotter Pin	1 or 2
13	TWO110-6	Tension Cable 120 ½ö	1 or 2

# TILT-A-WAY DCM SPRING TENSIONER UNIT

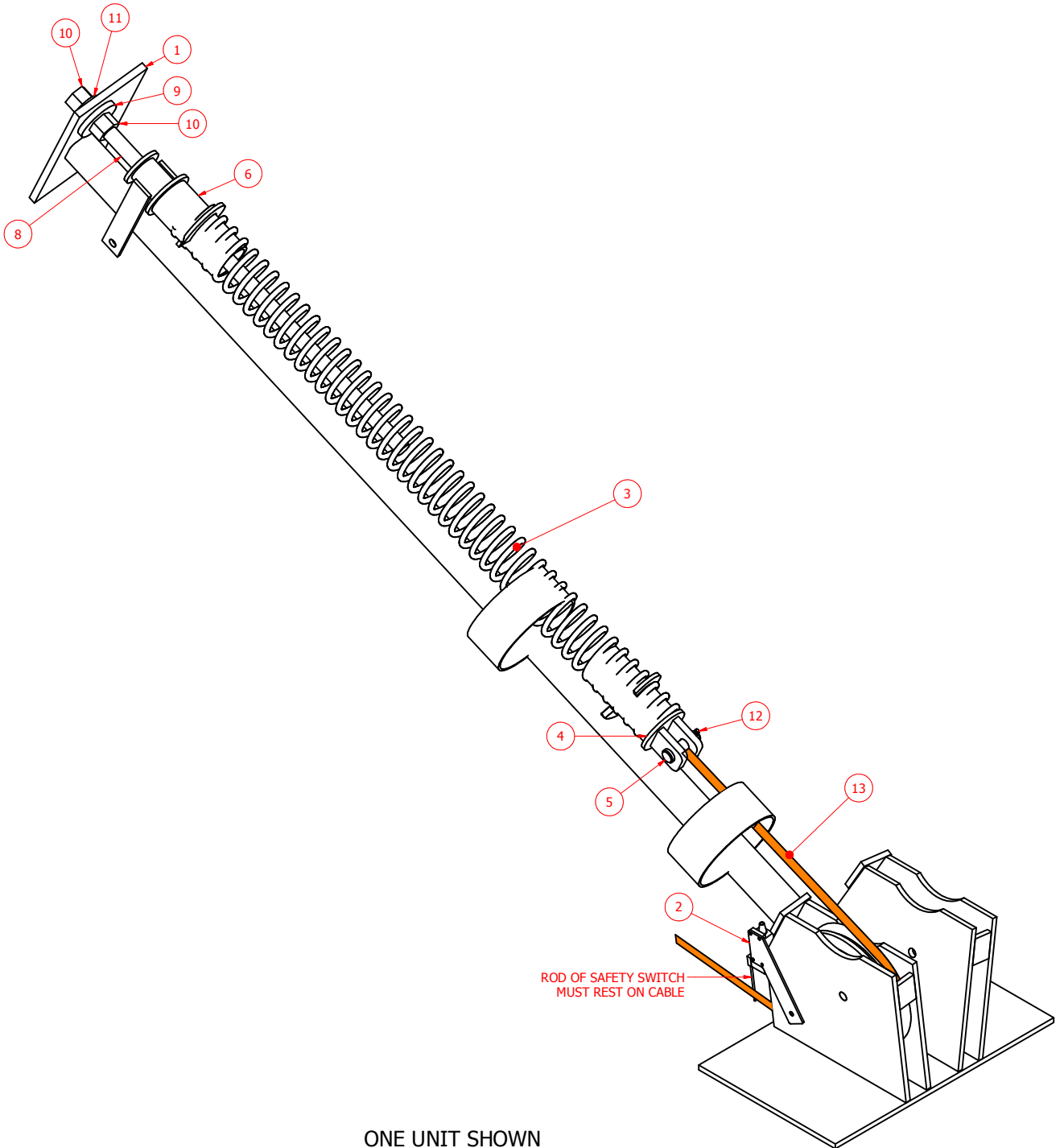

ONE UNIT SHOWN  
YOUR GATE MAY HAVE TWO

DRAWN	THenry	10/17/2013	<b>IDEAL MFG., INC.</b> 2011 Hamish Blvd. Billings MT 59101 Tel. (406) 656-4360	
CHECKED		3/23/2016		
QA			TITLE	
MFG			TILT-A-WAY DCM SPRING TENSIONER	
APPROVED			SIZE	DWG NO
			C	DCM-1011
			SCALE	REV
			SHEET 1 OF 1	



# TILT-A-WAY DCM ACTUATING SPROCKET DCM-1012

REF NO.	PART NO.	DESCRIPTION	REQ'D NO.
1	N/A	Grease Fitting	1
2	N/A	1/2-13 Nylock	1
3	N/A	Tek Screw	2
4	N/A	1/2-13 X 3 3/4ö Hex Bolt	4
5	N/A	1/2 Flat Washer	4
6	N/A	1/2 Lock Washer	4
7	N/A	1/2-13 Hex Nut	4
8	N/A	1/4-20 X 3ö Hex Bolt	1
9	N/A	1/4-20 X 1ö Hex Bolt	2
10	N/A	1/4 Flat Washer	6
11	N/A	1/4 Lock Washer	3
12	N/A	1/4-20 Hex Nut	3
13	N/A	Hex Nut	1
14	N/A	5/8-18 Jam Nut	1
15	N/A	# 8-32 Machine Screw X 1/2ö	8
16	N/A	# 8-32 Nut	8
17	N/A	# 8-32 X 3/8ö Set Screw	1
FGO408	FGO408	Carriage Pivot Linkage	1
FGO410B	FGO410B	Pivot Pin	1
FGO411	FGO411	Pivot Arm	1
FGO413	FGO413	Potentiometer Bracket	1
FGO414	FGO414	Potentiometer Sprocket	1
FGO635	FGO635	3/8 Key	1
FGO636	FGO636	Limit Switch Bracket A	2
FGO637	FGO637	Limit Switch Bracket B	2
PEO500	PEO500	Limit Switch (magnet half)	2
PEO500	PEO500	Limit Switch (contact half)	2
PEO502	PEO502	Potentiometer	1
TWO101	TWO101	Pillow Block Bearing	2
TWO313	TWO313	Linkage End	1
TWO420	TWO420	Sprocket	1
TWO429	TWO429	Shoulder Bolt	1

### Gate Barrier Adjustment

**Note: Before making adjustments to limit switches or linkage turn all power off.**

The gate barrier may need to be adjusted. If the free end of the barrier is low, or high, remove hairpin from carriage (see page 29). Loosen jam nut. Remove pivot pin. Turn linkage end clockwise to raise free end counter clockwise to lower free end. Reinstall pivot pin. Check gate barrier for level, and adjust as needed. When gate barrier is level tighten jam nut, and reinstall hairpin. Turn power back on and operate gate barrier. Watch for proper operation of gate system. The limit switches are factory set. Some adjustment maybe needed to the limit switches for proper gate close, and open position. If adjustment is needed turn all power off. Open access doors to reveal actuating sprocket (see page 29). The limit switch above the square tube that supports the sprocket bearing is the close limit. Limit switch below the same square tube is the open limit. Using 7/16 end wrench loosen the nut and bolt assembly for the appropriate limit switch. Do not loosen nut and bolt assembly that goes thru the square tube. Move the limit switch toward the magnet on the actuating sprocket to stop barrier travel sooner, away from magnet for more travel. Use small adjustments. Tighten nut and bolt assembly. Turn power on, and operate gate system. Repeat until barrier stops in the proper location. Reinstall side panel and access door. Turn power on, and check for proper operation. If the open or close limit switches have been adjusted then the carriage stops may need to be adjusted. See page 19 item FGO633 for close stop, and page 23 item 3 for open stop. When adjusting the stop the carriage should just touch the stops when the limit switch stops the carriage.

# TILT-A-WAY DCM ACTUATING SPROCKET

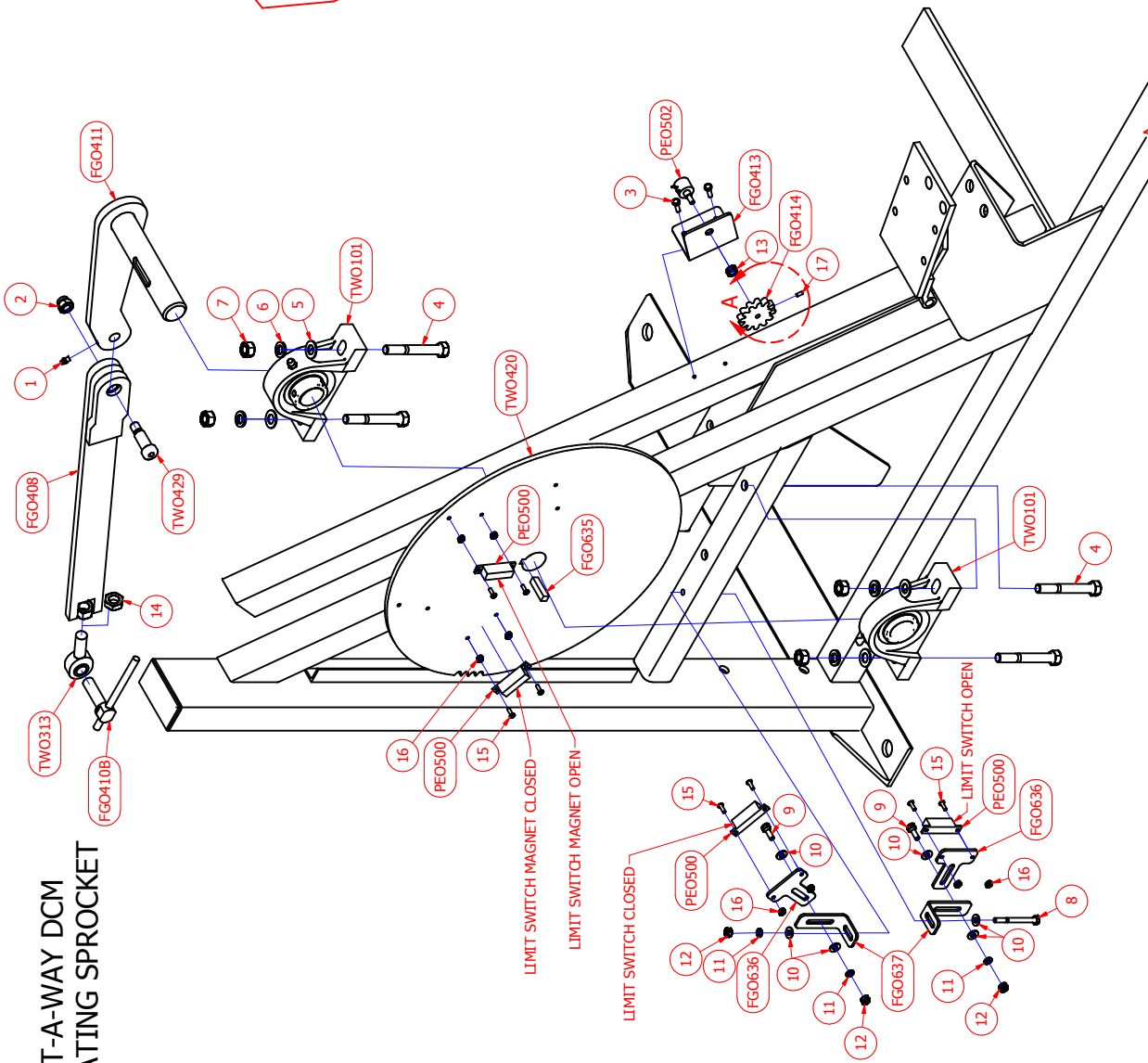

**DETAIL A**  
**SCALE 2 : 1**

POTENTIOMETER REPLACEMENT WITH THE GATE IN THE FULL CLOSED POSITION. THE POTENTIOMETER PART NUMBER PEO502 IS A 10 TURN POTENTIOMETER. CARE MUST BE TAKEN WHEN REPLACING TO BE SURE NOT TO TURN PAST STOPS. WHEN REPLACING POTENTIOMETER FOR RIGHT HAND OPERATOR ROTATE CLOCKWISE UNTIL THE STOP IS REACHED. ROTATE COUNTER CLOCKWISE 1/2 TURN. TURN BACK COUNTER CLOCKWISE 1/2 TURN. INSTALL PLASTIC SPROCKET AND TIGHTEN SET SCREW. FOR A LEFT HAND OPERATOR ROTATE COUNTER CLOCKWISE UNTIL THE STOP IS REACHED. THEN BACK 1/2 TURN CLOCKWISE.

DRAWN	10/21/2013	<b>IDEAL MFG, INC.</b>	
CHECKED	3/23/2016	2011 Harmish Blvd. Billings MT 59101 Tel. (406) 656-4360	
QA		TITLE	
MFG		TILT-A-WAY MODEL DCM ACTUATING SPROCKET	
APPROVED		SIZE	DWG NO
		C	DCM-1012
		SCALE	REV
		SHEET 1 OF 1	

**TILT-A-WAY DCM  
BALANCE SYSTEM CABLE, SPRING, AND SHEAVE REPLACEMENT  
INSTRUCTIONS**

**NOTE: TURN POWER OFF AND DISCONNECT BATTERIES BEFORE  
REPLACING BALANCE SYSTEM COMPONENTS.**

1. Open access doors, and turn power off, and disconnect batteries. If cable, or spring that is being replaced is on the opposite side from access doors remove side panels on that side.
2. Remove hairpin, and pivot pin from carriage. Manually raise barrier to about 45 degrees, and support the barrier with a sawhorse or equivalent to keep the barrier from closing.
3. Check for paint mark on square tube under tension spring by upper spring end. If there is no mark to indicate spring tension, make one to insure the spring is tightened to proper tension for balance.
4. Lubricate spring tension screw. Use a 1 5/8ö socket to turn tension screw nut counter clockwise to loosen spring, and clockwise to tighten spring.
5. **To replace broken cable.** Remove cotter pin from pin at the top of the carriage (see page 19 item ID1006). . Remove flat washer, and cable. Remove cotter pin from pin on lower spring end (see page 27 item 12). Remove pin, and cable. Remove nylock hex nut, and shoulder bolt from rear sheave plate holding on to the sheave (see page 24 item 6, 9, and 10). Remove sheave, and place new cable in between the two plates. Inspect bearing on sheave, and replace if bearing is bad (see page 24 item 11). Reinstall sheave, shoulder bolt, and nylock hex nut. Route the cable under the front sheave. It may be necessary to remove the front sheave to get the cable under it. If the sheave must be removed to replace cable make note of the hole the shoulder bolt passes thru. Place eye of cable on pin of carriage, and install flat washer, and cotter pin. Pull loose end of cable towards spring end. Make note of how far spring end must move to reach the free end of cable. Turn tension screw nut counter clockwise until the cable can be attached to spring end. Install the pin thru spring end, and cable eye. Secure with cotter pin. Be sure that rod on safety switch is to the inside of cable when tension springs are tighten (see page 24). Turn tension spring nut clockwise until upper spring end reaches the mark on the square tube. Check balance before hooking linkage back up to the carriage, and adjust accordingly. For balancing instructions see page 14.
6. **To replace broken spring.** Remove cotter pin from pin on lower spring end (see page 27 item 12). Inspect cable for broken strains. If there are 5 broken strains per lay, or 10 over all replace cable. Before unwinding spring refer to # 3 above. Turn tension screw nut counter clockwise until upper spring end comes of tension screw. If your replacement spring did not come with spring ends then you must reuse the ends from your broken spring. Start the new spring on the tension screw, and connect the cable using pin, and secure with cotter pin. Turning the tension screw nut clockwise watch the cable to make sure it is in the groove of both sheaves. Also be sure the rod on the safety switch is to the inside of the cable (see page 24 item 8). Tighten the spring up to the mark on the square tube. Check balance before hooking linkage back up to the carriage, and adjust accordingly. For balancing instructions see page 14.
7. **To replace sheave.** Before unwinding spring refer to # 3 above. Turn tension screw nut counter clockwise until there enough slack in cable to rotate the sheave freely by hand. If replacing rear sheave the cable will need to be disconnected from the spring end. Remove nylock hex nut and shoulder bolt. Remove the sheave, and replace with new sheave. Reinstall shoulder bolt, and nylock hex nut If the front sheave is being replaced make note of the hole the shoulder bolt is thru for reinstallation. Check balance before hooking linkage back up to the carriage, and adjust accordingly.
8. After checking balance, and adjusting the balance reinstall pivot pin, and hairpin.
9. Hook batteries back up, and turn power on. Cycle gate open, and closed to check for proper operation. Close and lock access doors.

# Tilt-A-Way DCM

## 24-volt dc gear motor program menu

3/23/2016

To Enter Main Menu press and hold button SW2 for about 4 seconds.  
To view menus press and release button SW4 to scroll up, and SW3 to scroll down.

To enter menu, or submenu press and release button SW1.

To save changes to submenus press, and release button SW1.

To exit submenus, or main menu press, and release button SW2.

- REALTIME STATUS. This menu is helpful for trouble shooting problems with the gate system.
  - Input Status. In this submenu you can view which inputs are active, or inactive.
    - Input state open button *"Input clear / Input asserted"*
    - Input state close button *"Input clear / Input asserted"*
    - Input state stop button *"Input clear / Input asserted"*
    - Input state single button *"Input clear / Input asserted"*
    - Input state reverse open, terminal *"Input clear / Input asserted"*
    - Input state timer set *"Input clear / input asserted"*
    - Input state timer hold *"Input clear / Input asserted"*
    - Input state aux timer *"Input clear / Input asserted"*
    - Input state UL reset (on board) *"Input clear / Input asserted"*
    - Input state remote (N.O. contact) *"Contact open / Contact closed"*
    - Input state remote (N.C. contact) *"Contact open / Contact closed"*
    - Input state loop slot #J3 *"Input clear / Input asserted"*
    - Input state loop slot #J5 *"Input clear / Input asserted"*
    - Input state loop slot #J7 *"Input clear / Input asserted"*
    - Input state auxiliary #1 *"Input clear / Input asserted"*
    - Input state auxiliary #2 *"Input clear / Input asserted"*
    - Input state leaf #1 close obstruct edge *"Input clear / Input asserted"*
    - Input state leaf #1 open obstruct edge *"Input clear / Input asserted"*
    - Input state leaf #1 close limit *"Input clear / Input asserted"*
    - Input state leaf #1 open limit *"Input clear / Input asserted"*
    - Input state leaf #2 close obstruct edge *"Input clear / Input asserted"*
    - Input state leaf #2 open obstruct edge *"Input clear / Input asserted"*
    - Input state leaf #2 close limit *"Input clear / Input asserted"*
    - Input state leaf #2 open limit *"Input clear / Input asserted"*

- Output Status. In this submenu you can view which output relays are latched, or unlatched.
  - Output state entrapment (K1) *“relay not energized / relay energized”*
  - Output state prewarn (K2) *“relay not energized / relay energized”*
  - Output state auxiliary #1 (K3) *“relay not energized / relay energized”*
  - Output state auxiliary #2 (K4) *“relay not energized / relay energized”*
  - Output state auxiliary #3 (K5) *“relay not energized / relay energized”*
- Motor Current. (for model DCM only) This submenu is used to view amp draw of the motor so the proper value can be inserted in the safety threshold submenu.
  - Leaf # 1 maximum deviation threshold, last cycle (gate stopped)
  - X.X A (gate stopped)
  - Motor Current Leaf #1 (gate moving)
  - Approx Motor Current (gate moving)
  - X.X A (this value changes as the gate moves thru a cycle. Watch for the highest value during the cycle to enter a proper setting in the safety threshold submenu leaf #1)
  - Leaf # 2 maximum deviation threshold, last cycle (gate stopped)
  - X.X A (gate stopped)
  - Motor Current Leaf #1 (gate moving)
  - Approx Motor Current (gate moving)
  - X.X A (this value changes as the gate moves thru a cycle. Watch for the highest value during the cycle to enter a proper setting in the safety threshold submenu leaf #2)
- Battery Voltage. (for model DCM only) This submenu shows voltage being supplied to the logic board. Any voltage over 24 vdc will show as 24 volts.
  - Leaf #1 / 24.0 volts
  - Leaf # 2 / 24.0 volts
- TIMING AND OPTIONS. In this menu you can adjust user settings.
  - Basic settings
    - Current clock time (factory set to mountain time) *“12:01 am”*
    - Current calendar date *“1/1/2013”*
    - Auto-Close delay (factory set at 10 seconds) *“OFF / 15:00”*
    - Close command over rides auto-close (factory set Enabled) *“Disabled / Enabled”*
    - Single input sets the auto-close timer (factory set Enabled) *“Disabled / Enabled”*
    - Single input direction reverse (factory set Enabled) *“Disabled / Enabled”*

- Pause delay before direction reversal (factory set Enabled) *“Disabled / Enabled”*
- Safety Responses
  - Maximum motor run (0:30 seconds factory set) *“0:05 to 1:30”*
  - Motion reversal on safety (factory set Enabled) *“Disabled / Enabled”*
  - Safety sets the auto-close timer (factory set Enabled) *“Disabled / Enabled”*
  - Inherent safety (for model DCM only factory set Enabled) *“Disabled / Enabled”*
  - Safety threshold Leaf # 1 closing (for model DCM only value set at factory, Inherent safety must be checked monthly) *“0.0 A to 20.0 A”*
  - Safety threshold Leaf # 1 opening (for model DCM only value set at factory, Inherent safety must be checked monthly) *“0.0 A to 20.0 A”*
  - Safety threshold Leaf #2 closing (for model DCM only value set at factory, Inherent safety must be checked monthly) *“0.0 A to 20.0 A”*
  - Safety threshold Leaf #2 opening (for model DCM only value set at factory, Inherent safety must be checked monthly) *“0.0 A to 20.0 A”*
  - Motor inrush ignore period (factory set 1.0 seconds) *“0.0 seconds to 2.0 seconds”*
  - Position Feedback Obstruction Detect (for hydraulic gate only) (factory set Disabled) *“Disabled / Enabled”*
  - Monitored Obstruction Edge *“Disabled / Enabled”*
- Speed Settings (for model DCM only)
  - Gate position for ramp up completion (factory set 5%) *“XX%”*
  - Gate position for ramp down start (factory set 80%) *“XX%”*
  - Slow stop ramp-down on gate reversal (factory set 0.5 seconds) *“0.0 seconds to 3.0 seconds”*
  - Motor ramp starting speed (factory set 60%) *“XX%”*
  - Maximum motor speed (factory set 100%) *“XX%”*
  - Motor ramp end speed (factory set 40%) *“XX%”*
- Lockout Schedule. When lockout schedule is set the gate will not open until lockout schedule ends except for a free exit loop will open the gate, or an input to terminal timer set input , I7.
  - Entry lockout enable Schedule # 1 *“Disabled / Enabled”*
  - Entry lockout start Schedule # 1 *“ set for time to start lockout am or pm and day of week”*
  - Entry lockout end Schedule # 1 *“set for time to end lockout am or pm and day of week”*
  - Repeat for all days that Lockout is needed.

- Auto-Open schedule. When auto-open schedule is set no function will close gate until auto-open schedule ends.
  - Auto-Open gate enable Schedule # 1 “*Disabled / Enabled*”
  - Auto-Open gate start time Schedule # 1 “*set for time to start auto-open am or pm and day of week*”
  - Auto-Open gate end time Schedule # 1 “*set for time to end auto-open am or pm and day of week*”
  - Repeat for all days that Auto-Open is needed.
  
- Battery (for model DCM only)
  - Fail-Safe / Fail-secure Selection “*fail safe / fail secure*”
  - Battery dropout voltage (factory set 18.0 volts) “*17.0 to 23.0*”
  - Battery recovery voltage (factory set 20.0 volts) “*18.0 to 23.0*”
  
- Auxiliary I / O
  - Auxiliary #1 input function assignment “*not used / open / close / stop / single / timer hold / reverse open loop / opening safety edge / closing safety edge / UL entrapment reset*”
  - Auxiliary #2 input function assignment “*not used / open / close / stop / single / timer hold / reverse open loop / opening safety edge / closing safety edge / UL entrapment reset*”
  - Auxiliary output #1 function “*output disabled / secondary entrapment alarm / hold aux relay when maintenance due / hold aux relay on auto-close delay / unlock pulse / pulse aux relay on close limit switch / pulse aux relay on open limit switch / pulse aux relay on open motion / pulse aux relay on close motion / hold aux relay on close limit switch / hold aux relay on open limit switch / hold aux relay on opening motion / hold aux relay on closing motion / pulse aux relay on motion prewarn / pulse aux relay on opening prewarn only / pulse aux relay on closing prewarn only / pulse aux relay on auxiliary input #1 / hold aux relay on auxiliary input #1 / pulse aux relay on auxiliary input #2 / hold aux relay on auxiliary input #2 / hold aux relay on any motion / hold aux relay on arming loop assertion*”
  - Auxiliary output #1 pulse duration “*0.1 seconds to 5.0 seconds*”
  - Auxiliary output #2 function “*output disabled / secondary entrapment alarm / hold aux relay when maintenance due / hold aux relay on auto-close delay / unlock pulse / pulse aux relay on close limit switch / pulse aux relay on open limit switch / pulse aux relay on open motion / pulse aux relay on close motion / hold aux relay on close limit switch / hold aux relay on open limit switch / hold aux relay on opening motion / hold aux relay on closing motion / pulse aux relay on motion prewarn / pulse aux relay on opening prewarn only / pulse aux relay on closing prewarn only / pulse aux relay on auxiliary input #1 / hold aux relay on auxiliary input #1 / pulse aux relay on auxiliary input #2 / hold aux relay on auxiliary input #2*”





- If service reminder on or after date is Enabled then the date can be set here “08/21/2021”
  - Test relays
    - Relay Test / Latch “no latched relays / latch relay K1 / latch relay K2 / latch relay K3 / latch relay K4 / latch relay K5”
  - Factory config. This submenu is for factory use only.
    - Caution! Apply volts and trim calibration “24.0 volts”
    - Caution! Zero life time cycle counter “no / yes”
    - Caution! Reset all settings to defaults “no / yes”
- Statistics
  - Gate Cycle Count
    - Total gate life time cycle count (000000)
    - Cycle count since last service reset (00000)
  - Motor board #1 bus. This submenu is factory use only.
  - Motor board #2 bus. This submenu is factory use only.
- Event Logs
  - General Event Log
    - Event #1 (most recent)
  - Safety Event Log
    - Event #1 (most recent)

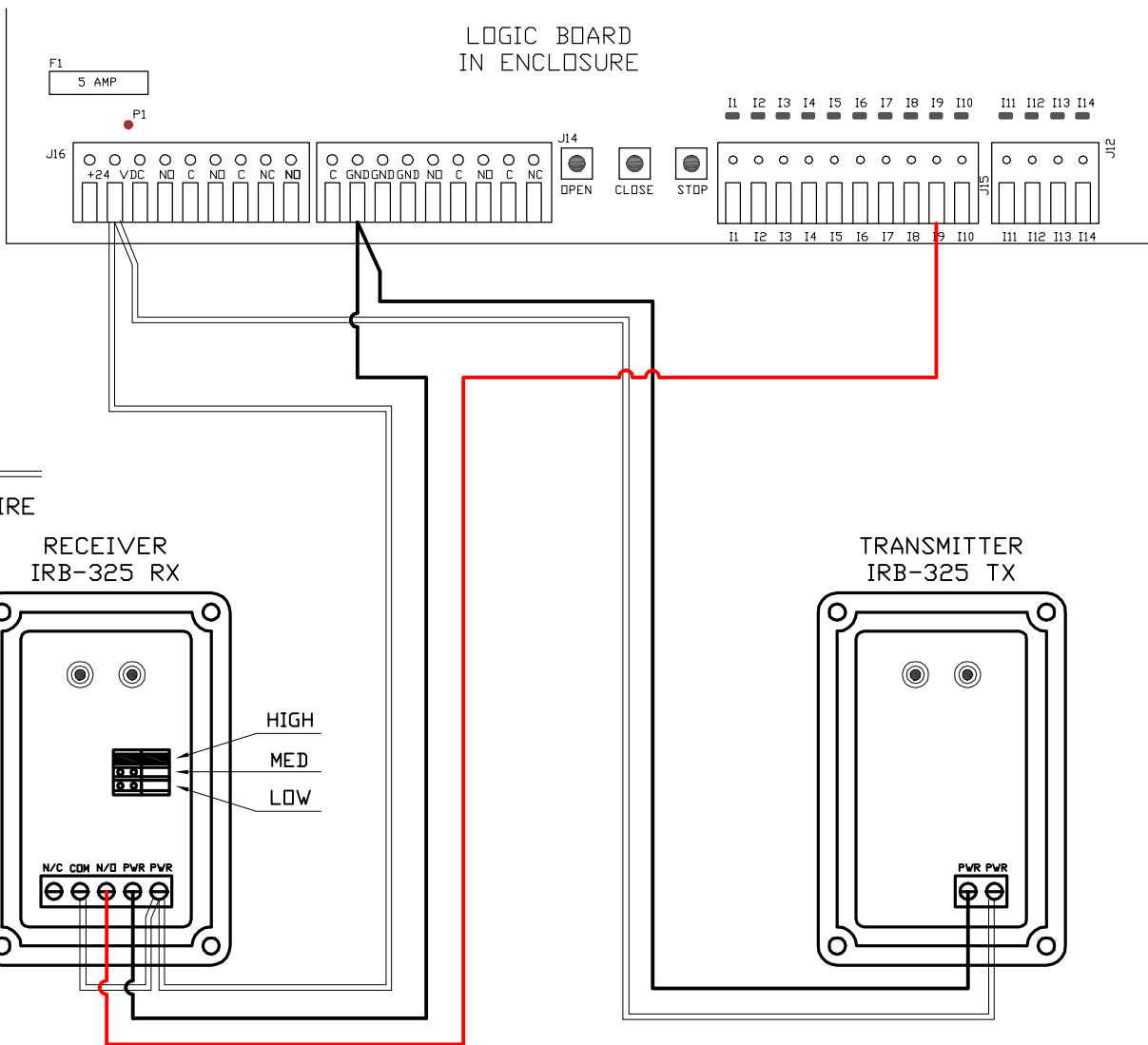

THE RECEIVER N/O CONTACT IS CONNECTED TO TERMINAL I9 ON THE LOGIC BOARD.  
 FOR THE PHOTO EYE TO ACT AS A SAFETY AUXILIARY #1 INPUT FUNCTION ASSIGNMENT WILL BE SET TO  
 "REVERSE OPEN LOOP"  
 PRESS AND HOLD BUTTON SW2 ON THE INTERFACE BOARD UNTIL DISPLAY CHANGES THEN RELEASE THE BUTTON  
 PRESS BUTTON SW4 AND RELEASE UNTIL THE DISPLAY SHOWS  
 "TIMING AND OPTIONS"  
 PRESS AND RELEASE BUTTON SW1 TO ENTER THE MENU THE DISPLAY WILL CHANGE TO  
 "TIMINGS AND OPTIONS"  
 "BASIC SETTINGS"  
 CONTINUE TO PRESS AND RELEASE BUTTON SW4 UNTIL THE DISPLAY SHOWS  
 "TIMINGS AND OPTIONS"  
 "AUXILIARY I / O"  
 PRESS AND RELEASE BUTTON SW1 TO ENTER THE SUBMENU THE DISPLAY WILL SHOW  
 "AUXILIARY # 1 INPUT FUNCTION ASSIGNMENT"  
 PRESS AND RELEASE BUTTON SW1 TO ENTER  
 PRESS AND RELEASE BUTTON SW4 UNTIL THE DISPLAY SHOWS  
 "REVERSE OPEN LOOP"  
 PRESS AND RELEASE BUTTON SW1 TO SAVE  
 PRESS AND RELEASE BUTTON SW2 UNTIL YOU EXIT ALL MENUS  
 THE GATE WILL STOP AND REVERSE WHEN CLOSING TO FULL OPEN AND SET THE AUTO CLOSE TIMER

**TILT-A-WAY DCM  
 REFLECTIVE TYPE PHOTO EYE**

REF NO.	PART NO.	DESCRIPTION	REQ NO
1	PEO404 (set)	Photo Eye 24-VDC	1
2	PEO405	Hood ( not shown)	2

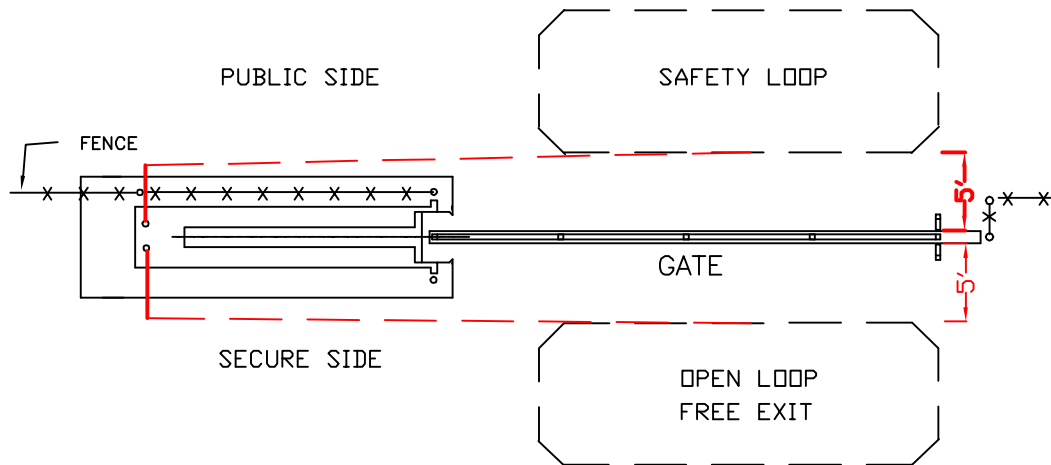

NOTE: MAKE LOOPS APPROPRIATE FOR ROADWAY  
AND SET BACK FROM GATE BARRIER 5 FEET

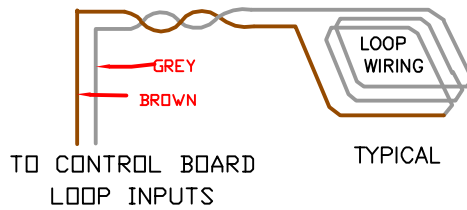

NOTE:

Lead wires from more than one loop installation may be routed in same conduit if wires from each individual loop are twisted at least 6 turns per 12 inches.

### TILT-A-WAY DCM ELECTRICAL LOOP WIRING



# ULT-PLG ULTRALOOP

## Vehicle Loop Detector



CE

# Operating Instructions



## Instruction Manual

The ULT-PLG plug-in style vehicle loop detector senses metallic objects near an induction loop. This vehicle detector may be used in center, reverse and exit loop positions. The ULTRAMETER™ display allows for easy set-up by displaying the optimum sensitivity setting for detecting a vehicle near the loop while ignoring interference. Ten sensitivity settings allow for fine adjustment of the detection level. The ULT-PLG features a user configurable Output B for fail safe/secure, pulse on entry/exit, presence or EMX exclusive, Detect-on-Stop™ (DOS®). Four frequency settings provide flexibility in preventing crosstalk in multi-loop applications.

### Cautions and Warnings



This product is an accessory or part of a system. Install the ULT-PLG according to instructions from the gate or door operator manufacturer. Comply with all applicable codes and safety regulations.

### Specifications

Power	12-24 VDC
Draw Current	15 mA
Loop Frequency	4 settings (low, med-low, med-hi, high)
Loop Inductance Range	20-2000 $\mu$ H (Q factor $\geq$ 5)
Surge Protection	Loop circuitry protected by surge suppressors
Operating Temperature	-40° to 180°F (-40° to 82°C) 0 to 95% relative humidity
Connector	10 pin female
Dimensions (L x W x H)	3.0" (76 mm) x 0.9" (22 mm) x 2.75" (70 mm)

### Ordering Information

- ULT-PLG      Plug-in vehicle loop detector (included)
- PR-XX      Lite preformed loop (XX – specify size)
- TSTL      Test loop, troubleshooting tool

# Wiring Connections

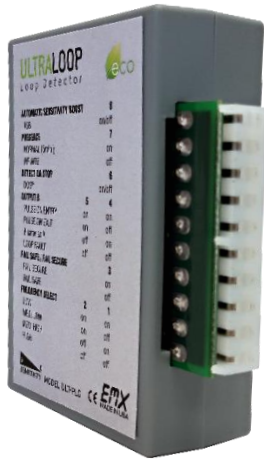

## 10 Pin Female Connector

Connector Pin	Description
1	Loop Connection
2	Loop Connection
3	Power + (12-24 VDC)
4	No Connection
5	No Connection
6	Output B
7	Output B Inverted
8	Presence Output
9	Power + (12-24 VDC)
10	Ground

# Settings & Display

## 1. DIP Switch

The DIP switch settings are explained on the next page.

## 2. Sensitivity Setting

The 10-position rotary switch allows for adjustment of detection threshold. The sensitivity threshold increases from position 0 (lowest setting) through 9 (highest setting). Typical applications require a setting of 3 or 4. The rotary adjustment must be set to a specific/whole number. There are no half settings.

## 3. Power / Loop Fault Indicator (Green LED)

Normal Operation	on
Shorted or Open Loop	fast flash
Previous Loop Fault	flashes fast twice intermittently

Upon power up, the detector initializes by automatically tuning to the loop. The green LED indicates that the detector is powered and operational.

## 4. Detect / Frequency Count (Red LED)

Presence Detected	on
No Presence	off
Frequency Count	flashing

## 5. ULTRAMETER™ Display

The display shows the sensitivity setting required to detect a vehicle near the loop. To use this feature, observe the display while a vehicle is moving into position near the loop, note the number displayed, then adjust the sensitivity setting to the displayed position. The display will adjust from 9 for a weak signal to 0 for a very strong signal. During normal operation, when a vehicle is not on or near the loop, the display is blank. The effects of cross-traffic interference can be observed on the display when the sensing area is vacant.

## 6. Frequency Count / Reset Button

Press and release the frequency count button and count the number of flashes on the red LED. Each flash represents 10 kHz. Following a frequency count cycle, the detector re-initializes.



<b>Automatic Sensitivity Boost</b>	<b>DIP Switch 8</b>
<i>ASB Enabled</i>	on
<i>ASB Disabled</i>	off

The **Automatic Sensitivity Boost** causes the sensitivity to increase following initial detection. This feature is useful to prevent dropout when detecting high-bed vehicles. The sensitivity returns to its normal setting after the vehicle exits the loop. The decimal point on the ULTRAMETER™ display indicates ASB is on.

<b>Presence</b>	<b>DIP Switch 7</b>
<i>Normal</i>	on
<i>Infinite</i>	off

**Infinite** presence mode causes the output to remain in detect as long as the vehicle remains on the loop. **Normal** presence mode causes the output to reset after 5 minutes. **Do not use Normal presence mode for reversing loop applications.**

<b>Detect-On-Stop™</b>	<b>DIP Switch 6</b>
<i>DOS® On</i>	on
<i>DOS® Off</i>	off

The **Detect-On-Stop™ (DOS®)** feature requires that a vehicle must come to a complete stop over the loop for a minimum of 1-2 seconds before Output B activates. DOS® will not function if in Loop Fault mode. **Do not use DOS® feature for reversing loop applications.**

<b>Output B</b>	<b>DIP Switch</b>	
<b>Mode</b>	<b>5</b>	<b>4</b>
<i>Pulse on Entry</i>	on	on
<i>Pulse on Exit</i>	on	off
<i>B same as A</i>	off	on
<i>Loop Fault</i>	off	off

Output B is configurable for four possible modes. In **Pulse on Entry/Exit** mode, Output B will be activated for approximately 500ms when a vehicle is entering or exiting the detection zone. In **B same as A**, relay B has the same output as relay A. In **Loop Fault** mode, the relay will trigger if a loop fault occurs.

<b>Fail Safe / Secure</b>	<b>DIP Switch 3</b>
<i>Fail Safe</i>	on
<i>Fail Secure</i>	off

The **Fail Safe** setting causes the ULT-PLG to activate the presence output in the event of a loop failure. The **Fail Secure** setting will cause the ULT-PLG not to activate the presence output in the event of a loop failure. **Do not use Fail Secure for reversing loop applications.**

<b>Frequency Settings</b>	<b>DIP Switch</b>	
	<b>2</b>	<b>1</b>
<i>Low</i>	on	on
<i>Medium Low</i>	on	off
<i>Medium High</i>	off	on
<i>High</i>	off	off

DIP switches 2 and 1 are used to assign the loop operation frequency. The primary purpose of the **Frequency Setting** is to allow the installer the ability to set different operating frequencies for multi-loop installations and is recommended to prevent crosstalk/interference from multiple loops.

# Loop Installation

## NEW SLAB POUR

Ty-wrap 1-1/4" PVC pipe to the top of the rebar in the size and configuration of the loop (ex. 4' x 8'). Then ty-wrap the loop to the top of the PVC frame. This stabilizes the loop during the pour and separates it from the rebar.

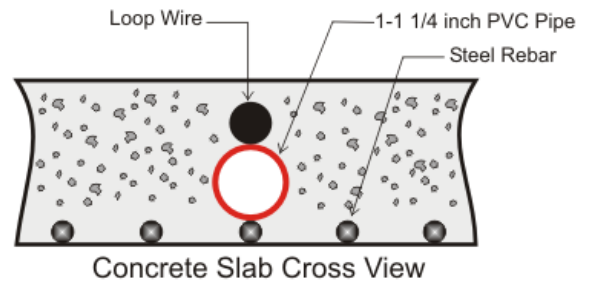

## SAW CUT EXISTING SURFACE

Cut 1" deep into the existing surface, place a 45° cut at the corners to prevent sharp edges from damaging the loop wire. Notch out for the "T" connection where the lead wire connects to the loop. Remove all debris from the finished cut with compressed air. Place the loop into the saw cut. Place backer material into the saw cut over the loop wire and pack tightly. Place a high-quality sealer over the saw cut to seal the surface.

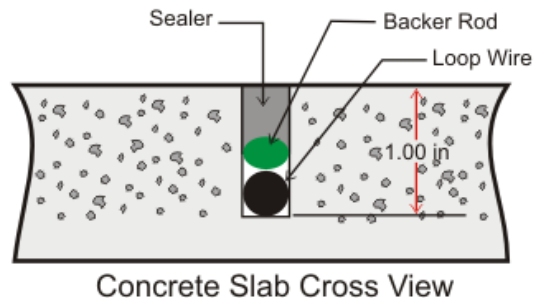

## RESURFACE ASPHALT

Saw cut the existing surface 3/4" deep and place a 45° cut at the corners to prevent sharp edges from damaging the loop wire. Remove all debris from the finished cut with compressed air. Place sand over the loop wire to the surface and pack tightly. Lay new asphalt.

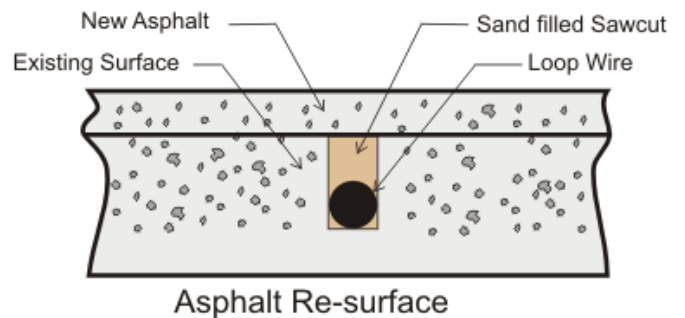

## GRAVEL OR SOIL INSTALLATION

While this is not a recommended installation for most loops, it has been used successfully with proper preparation. Remove gravel or top soil until reaching a stable base. Dig ~ 6-8" deep by ~ 6-8" wide. Fill halfway with sand and pack tightly. Place the loop into the trench and finish filling to level with sand. Pack tightly and replace gravel or soil over top.

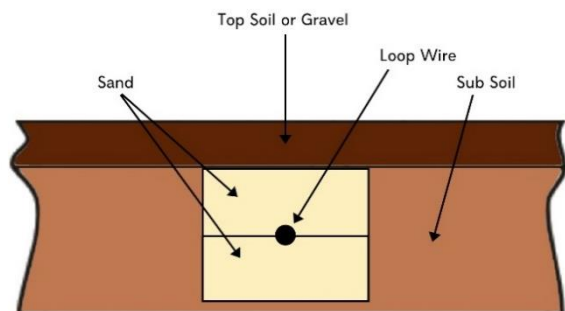

## GENERAL INSTALLATION GUIDELINES

- Use EMX lite preformed loops for quick, reliable installations.
- It is not recommended to install a loop near power lines (overhead or underground) or low voltage lighting. If necessary near these power sources, place at a 45° angle. Make the loop shape a diamond, not a square.
- Never install a loop near inductive heaters.
- If using a non-preformed loop, lead-in wire (wire from loop to detector) must be twisted a minimum of 6 turns per foot to avoid the effects of noise or other interference.
- Detection height is approximately 70% of the shortest side of the loop.  
For example: detection height for a 4' x 8' loop = 48" x .7 = 33.6"



## Installation

1. Plug the ULT-PLG into the operator according to instructions provided by the manufacturer.
2. Configure the DIP switches according to preferences. Refer to [Settings & Display](#) for more information.
3. If using multiple loops or suspect crosstalk/interference from the environment, perform a frequency count on each detector to confirm that the operation frequencies are different.
  - Press the FREQUENCY COUNT / RESET button and count the number of flashes of the red LED. Each flash represents 10kHz. Counts from 3 to 13 confirm that the detector is tuned to a loop.
  - If multiple loops and detectors are utilizing the same or very similar frequency, configure DIP switches 7 and 8 on one of the devices. For example: Move one ULT-PLG to the low frequency setting and the second ULT-PLG to the high frequency setting.
4. Press the FREQUENCY COUNT / RESET button to re-initialize the detector and program the DIP switch settings.
5. Adjust the sensitivity setting to desired level to assure detection of all vehicle traffic.
  - TIP:** • To test the sensitivity, without moving the sensing loop, drive a vehicle near the loop. When the vehicle is first detected by the loop, "9" will be displayed on the ULTRAMETER™ display. Position the vehicle over the loop where the detection point is desired, take note of the number displayed on the ULTRAMETER™ and change the sensitivity setting (10-position rotary switch) to match that number.
  - Move the test vehicle away from the loop to remove it from the detection zone (ULTRAMETER™ display should be blank).
  - Press the FREQUENCY COUNT / RESET button on the ULT-PLG.
  - Retest the product by moving the vehicle into and out of the detection zone to make sure the set-up and location are working as intended.
6. Press the FREQUENCY COUNT BUTTON / RESET button to calibrate the ULT-PLG to the loop.

## Troubleshooting

Symptom	Possible Cause	Solution
Green LED not on	No power	Check the power supplied to the ULT-PLG on pins 9 and 10. Voltage should read between 12-24 VDC.
Green LED fast flash	Loop wire shorted or open	<ol style="list-style-type: none"> <li>1. Check the loop resistance with a multimeter to confirm a reading between 0.5 ohms and 5 ohms. If the reading is outside of this range, replace the loop. The reading should be steady.</li> <li>2. Check loop connections to terminals.</li> <li>3. Press the FREQUENCY COUNT / RESET button.</li> </ol>
Green LED flashes fast twice intermittently	Loop wire was previously shorted or open	<ol style="list-style-type: none"> <li>1. Check the loop resistance with a multimeter to confirm a reading between 0.5 ohms and 5 ohms. If reading is outside of this range, replace the loop. The reading should be steady.</li> <li>2. Check loop connections to terminals.</li> <li>3. Press the FREQUENCY COUNT / RESET button.</li> </ol>
Red LED on constantly (stuck in detection mode)	<p>Faulty loop</p> <p>Poorly crimped connection or loose connection</p>	<p>Perform a megger test from loop lead to ground, it should be more than 100 megaohms.</p> <p>Check loop connections to terminals. Verify splices are properly soldered and sealed against moisture.</p> <p>Observe ULTRAMETER™ display. The level indicated on the display indicates residual frequency shift from vacant loop to vehicle presence. Press FREQUENCY COUNT / RESET button to re-initialize the detector.</p>
Detector detects intermittently when no vehicle is on the loop	<p>Faulty loop</p> <p>Poorly crimped connection or loose connection</p> <p>Cross-talk between multiple loop detectors</p> <p>Loop not securely installed to prevent movement of loop in pavement.</p>	<p>Perform a megger test from loop lead to ground, it should be more than 100 megaohms.</p> <p>Check loop connections to terminals. Verify splices are properly soldered and sealed against moisture.</p> <p>Set multiple loops to different frequencies.</p> <p>Verify that loop is securely installed in pavement and that site is in good condition preventing movement of loop wires.</p>
No detection	<p>Loop wire shorted or open</p> <p>Loop sensitivity set too low</p>	<ol style="list-style-type: none"> <li>1. Check loop resistance with a multimeter to confirm a reading between 0.5 ohms and 5 ohms. If the reading is outside of this range, replace the loop. The reading should be steady.</li> <li>2. With vehicle on loop, observe ULTRAMETER™ display. Set sensitivity level to the level indicated on the display.</li> </ol>

## Warranty

EMX Industries, Inc. products have a warranty against defects in materials and workmanship for a period of two years from date of sale to our customer.

BLANK PAGE

BLANK PAGE

BLANK PAGE

BLANK PAGE



4564 Johnston Parkway  
Cleveland, Ohio 44128  
United States of America  
[www.emxinc.com](http://www.emxinc.com)

Technical Support: (216) 834-0761  
[technical@emxinc.com](mailto:technical@emxinc.com)

Sales: (216) 518-9888  
Fax: (216) 518-9884  
[salesupport@emxinc.com](mailto:salesupport@emxinc.com)



# TILT-A-WAY DCM LOOP DETECTOR SOCKET DIAGRAM

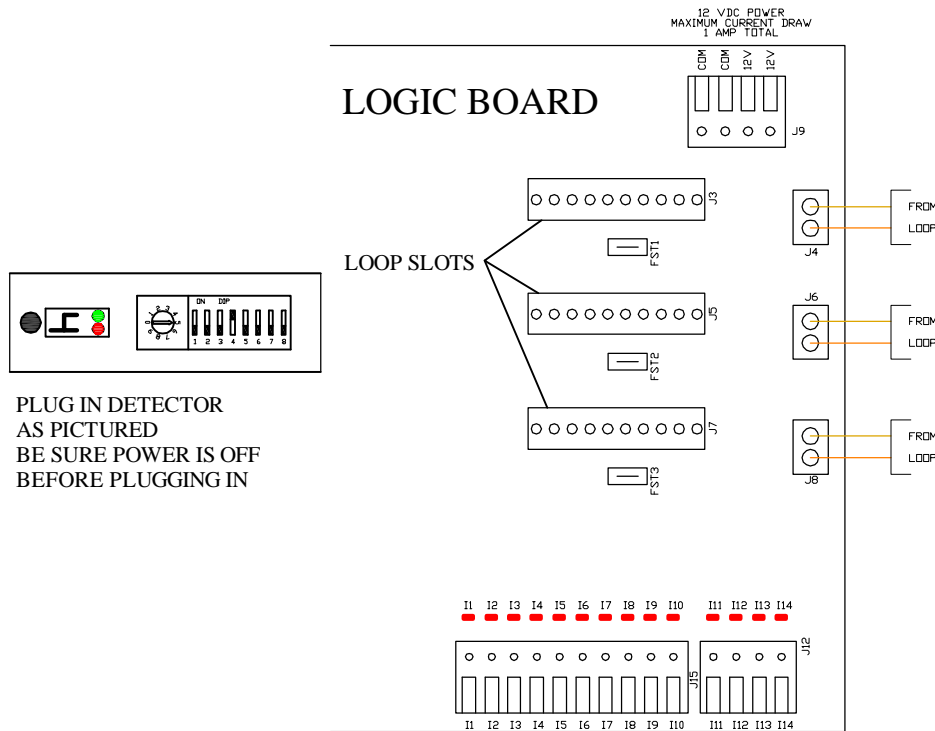

TILT-A-WAY DCM  
THERE ARE THREE LOOP SLOTS J3, J5, AND J7 THAT CAN BE PROGRAMMED FOR SEVERAL DIFFERENT FUNCTIONS  
LOOP SLOT DISABLED / SAFETY LOOP / FREE EXIT LOOP / SHADOW LOOP / ARMING LOOP  
TO ACCESS THESE FUNCTIONS PRESS AND HOLD BUTTON SW2 ON THE INTERFACE BOARD FOR ABOUT 4 SECONDS  
UNTIL THE DISPLAY CHANGES TO SHOW

### MAIN MENU

UP / DOWN - VIEW MENUS

SELECT - VIEW / EDIT

RESET - EXIT

PRESS AND RELEASE BUTTON SW4 UNTIL THE DISPLAY CHANGES TO

### TIMING AND OPTIONS

PRESS AND RELEASE BUTTON SW1 TO ENTER THIS MENU

PRESS AND RELEASE BUTTON SW4 UNTIL THE DISPLAY SHOWS

### LOOP AND REMOTE ASSIGNMENT

PRESS AND RELEASE BUTTON SW1 TO ENTER SUBMENU

THE DISPLAY WILL SHOW

### LOOP FUNCTIONALITY ASSIGNMENT J3 SLOT

USE BUTTON SW4 TO SCROLL THRU THE SUBMENU UNTIL THE SLOT THAT YOU WANT TO ACCESS IS SHOW

PRESS AND RELEASE BUTTON SW1 TO ENTER

USE BUTTON SW4 TO SCROLL THRU THE FUNCTION ASSIGNMENTS UNTIL THE DESIRE FUNCTION IS SHOW

PRESS AND RELEASE BUTTON SW1 TO SAVE

USE BUTTON SW4 TO CHANGE TO THE NEXT LOOP SLOT TO BE PROGRAMMED AND REPEAT

TO ASSIGN FUNCTIONS TO ALL SLOTS USED

WHEN ALL SLOTS HAVE BEEN PROGRAMMED PRESS AND RELEASE BUTTON SW2 TO EXIT SUBMENU

REPEAT UNTIL YOU HAVE EXITED ALL MENUS

**SAFETY LOOP** WILL STOP AND REVERES A CLOSING GATE, AND HOLD AN OPEN GATE OPEN UNTIL CLEARED

**FREE EXIT** WILL OPEN A CLOSED GATE AND STOP AND REVERSES A CLOSING GATE AND HOLD IT OPEN UNTIL CLEARED

**SHADOW LOOP** WILL HOLD OPEN A FULLY OPENED GATE UNTIL CLEARED

**ARMING LOOP** WILL LATCH AN AUXILIARY OUTPUT RELAY IF THE AUXILIARY OUTPUT RELAY FUNCTION

**HOLD AUX RELAY ON ARMING LOOP ASSERTION** HAS BEEN SELECTED IN THE **AUXILIARY I / O** SUBMENU IN

**TIMING AND OPTIONS** MENU



# TILT-A-WAY DCM MONITORED REVERSING EDGE INSTALLATION

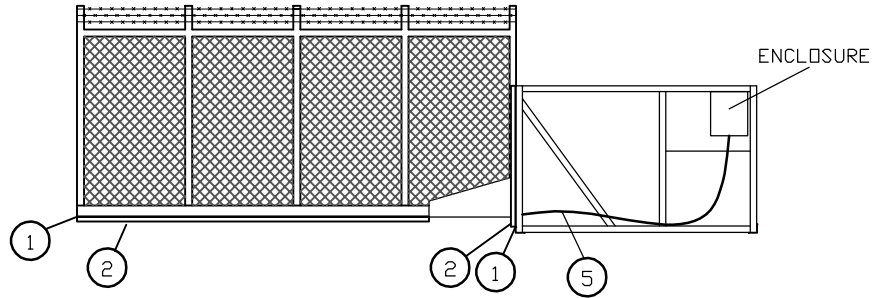

NOTE: FOR THE MONITORED EDGE TO FUNCTION PROPERLY IT MUST BE ENABLED. THIS FUNCTION IS IN THE TIMING AND OPTIONS MENU. SAFETY RESPONSES SUB MENU. MONITORED OBSTRUCTION EDGE (DISABLED / ENABLED)

TWO 9.09K OHMS RESISTORS ON EACH CIRCUIT

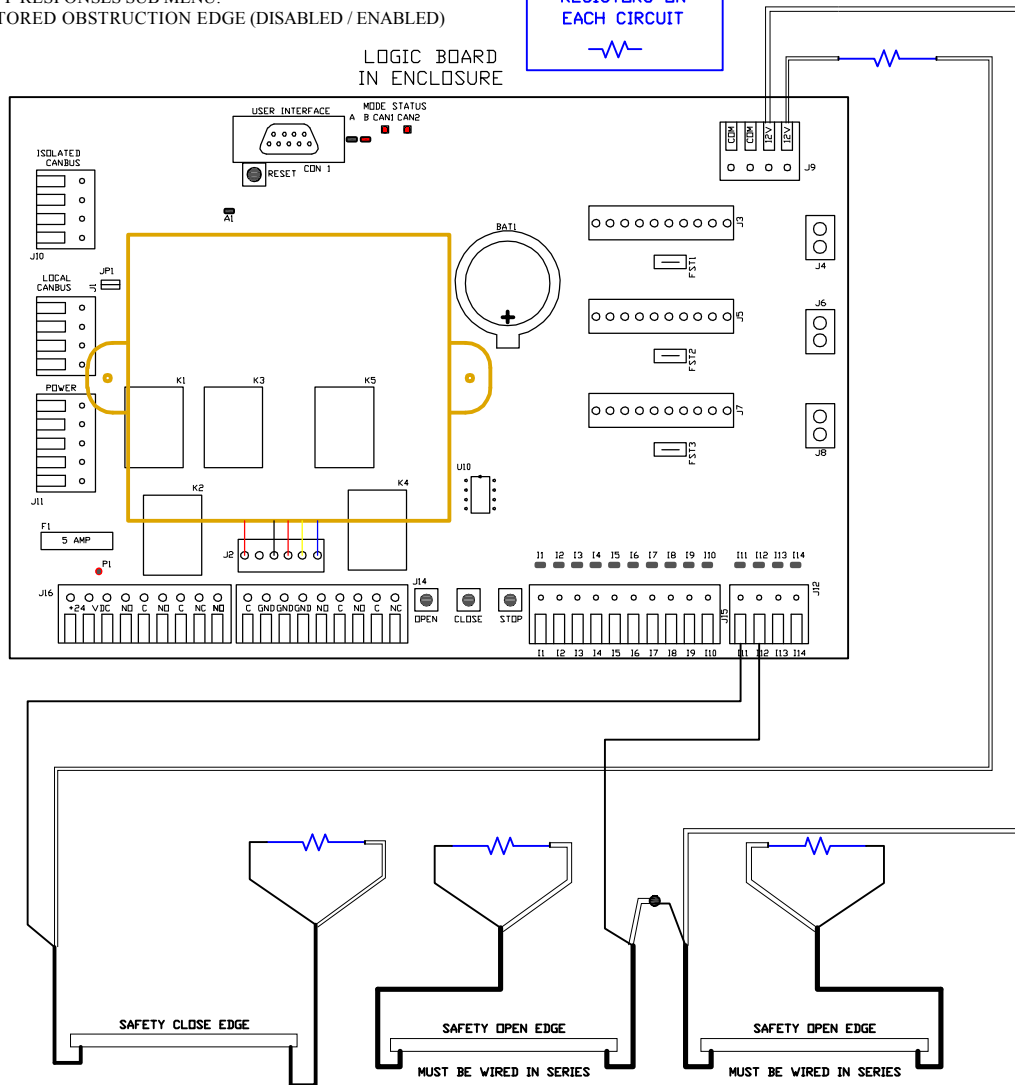

REF NO.	PART NO.	DESCRIPTION	REQ NO
1	PEO653	Opening Edge Holding Track	1
2	PEO651-A	Open safety, four wire edge two cables	2
3	PEO652-A-Length	Close safety, four wire edge two cables	1
4	PEO654	Closing Edge Holding Track (Length is required)	1
5	PEO410	Junction Box	1
6	N/A	18/5 S O Cord	AS REQ
	PEO246	1/2" Strain Relief Fitting (not shown)	4
	PEO237	Junction Box Cover (not shown)	1

## TILT-A-WAY DCM REVERSING EDGE INSTALLATION

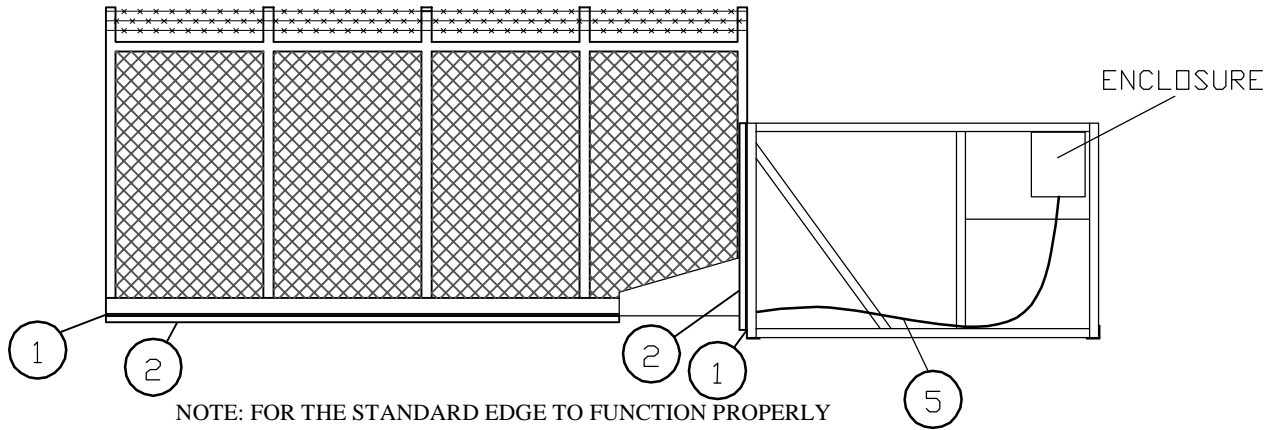

NOTE: FOR THE STANDARD EDGE TO FUNCTION PROPERLY THE MONITORED OBSTRUCTION EDGE MUST BE DISABLED. THIS FUNCTION IS IN THE TIMING AND OPTIONS MENU. SAFETY RESPONSES SUB MENU. MONITORED OBSTRUCTION EDGE (DISABLED / ENABLED)

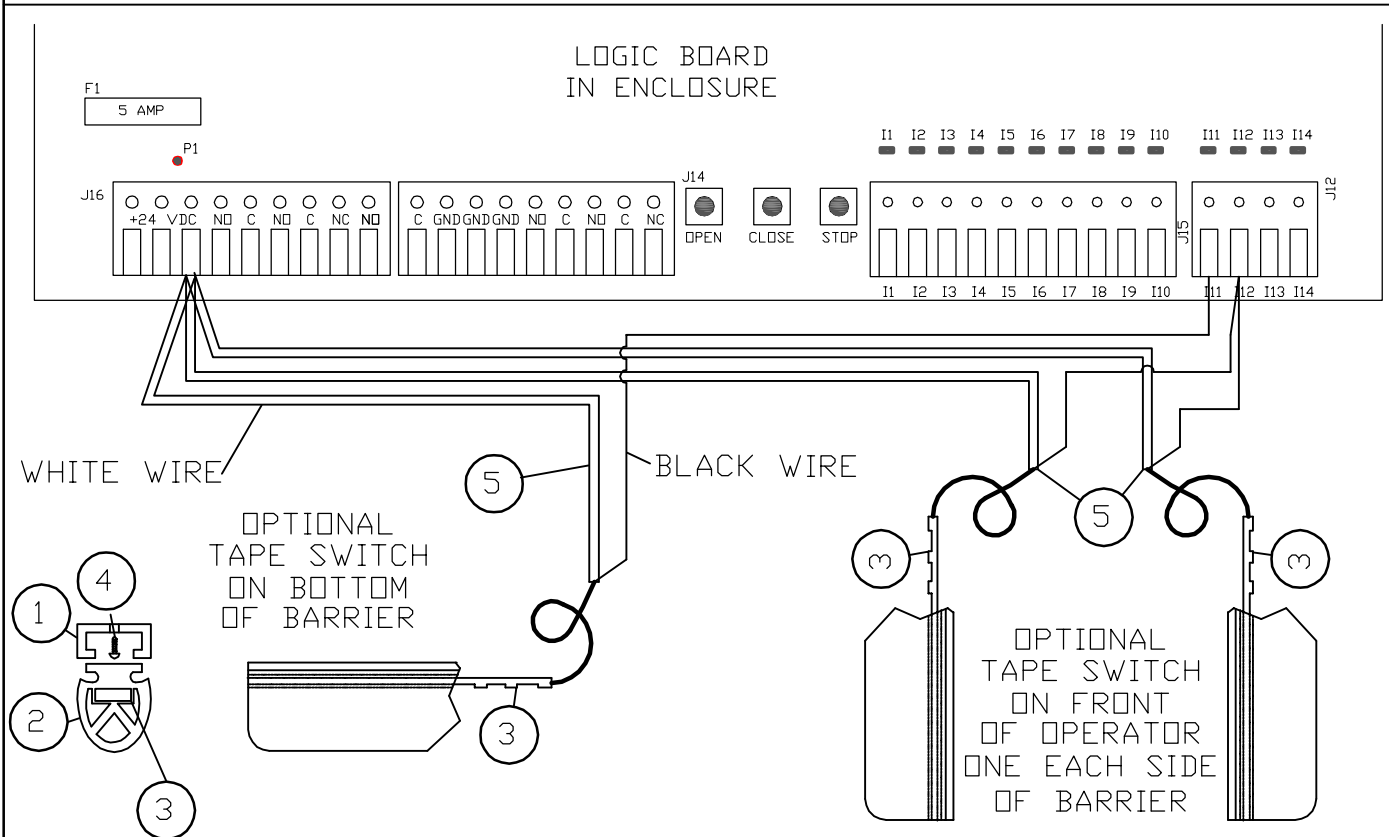

CONNECT CLOSING TAPE SWITCH BLACK WIRE TO TERMINAL I11  
CONNECT OPENING TAPE SWITCH BLACK WIRE TO TERMINAL I12

REF NO.	PART NO.	DESCRIPTION	REQ NO
1	PEO243	Reversing Edge Holding Track (Length is required)	1
2	PEO243A	Reversing Edge Rubber Strip (Length is required) (Insert in track from front)	1
3	PEO244-Length	C Switch (Order length as required) (Insert in track from front)	1
4	N/A	8 X 3/4" Tapping Phillips Pan Head Screw	as req.
5	N/A	Cord From C Switch	

**TILT-A-WAY  
DCM  
12 VOLT DC  
SAFETY WARNING LIGHT**

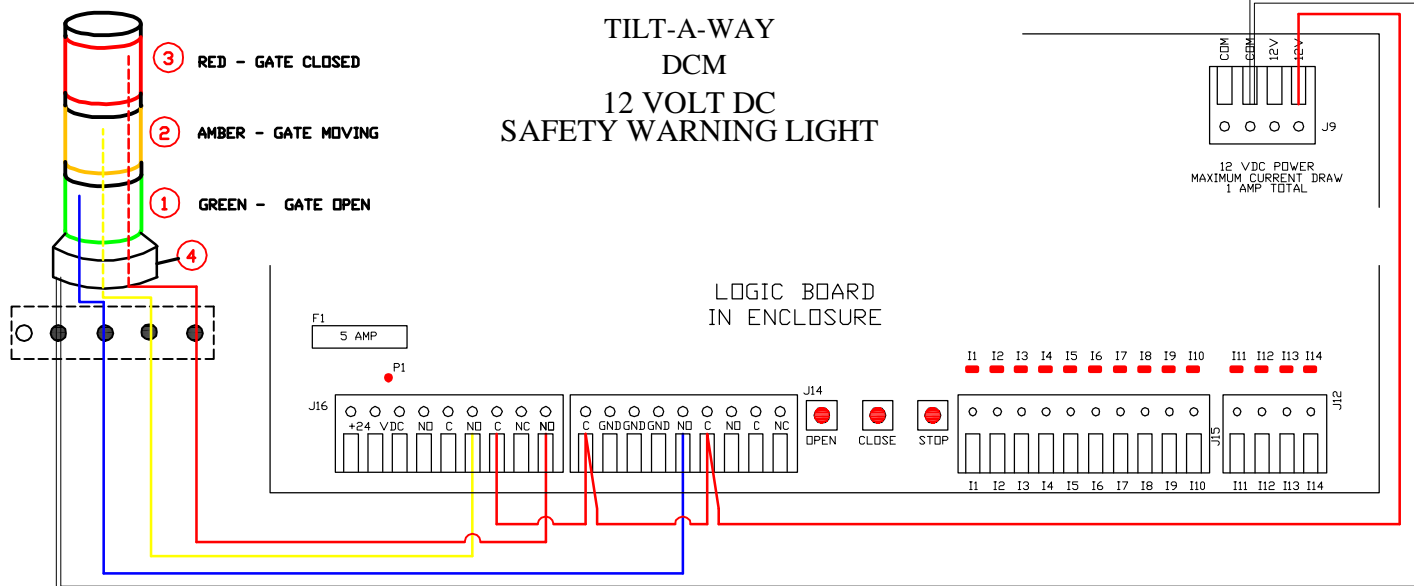

WHITE WIRE

TILT-A-WAY DCM  
12 VOLT DC SAFETY WARNING LIGHTS ARE CONNECTED TO THE NORMALLY OPEN CONTACTS  
RED LIGHT "GATE CLOSED" IS CONNECTED TO AUXILIARY OUTPUT # 1  
AMBER LIGHT "GATE MOVING" IS CONNECTED TO PREWARN OUTPUT  
GREEN LIGHT "GATE OPEN" IS CONNECTED TO AUXILIARY OUTPUT # 2  
THE OUTPUT FUNCTIONS FOR AUXILIARY OUTPUT # 1 AND # 2 NEED TO BE SET AS FOLLOWED  
PRESS AND HOLD BUTTON SW2 ON THE INTERFACE BOARD UNTIL THE DISPLAY CHANGES  
RELEASE THE SW2 BUTTON AND THE DISPLAY WILL SHOW

**MAIN MENU**

**UP / DOWN - VIEW MENUS**

**SELECT - VIEW / EDIT**

**RESET - EXIT**

PRESS AND RELEASE BUTTON SW4 UNTIL THE DISPLAY SHOWS

**TIMING AND OPTIONS**

PRESS AND RELEASE BUTTON SW1 TO ENTER THE MENU

PRESS AND RELEASE BUTTON SW4 UNTIL THE DISPLAY SHOWS

**AUXILIARY I / O**

PRESS AND RELEASE BUTTON SW1 TO ENTER THE SUBMENU

PRESS AND RELEASE BUTTON SW4 UNTIL THE DISPLAY SHOWS

**AUXILIARY OUTPUT # 1 FUNCTION**

PRESS AND RELEASE BUTTON SW1 TO ENTER THE SUBMENU

PRESS AND RELEASE BUTTON SW4 UNTIL THE DISPLAY SHOWS

**HOLD AUX RELAY ON CLOSE LIMIT SWITCH**

PRESS AND RELEASE BUTTON SW1 TO SAVE SELECTION

PRESS AND RELEASE BUTTON SW2 TO EXIT SUBMENU

PRESS AND RELEASE BUTTON SW4 UNTIL DISPLAY SHOWS

**AUXILIARY OUTPUT # 2 FUNCTION**

PRESS AND RELEASE BUTTON SW1 TO ENTER THE SUBMENU

PRESS AND RELEASE BUTTON SW4 UNTIL THE DISPLAY SHOWS

**HOLD AUX RELAY ON OPEN LIMIT SWITCH**

PRESS AND RELEASE BUTTON SW1 TO SAVE SELECTION

PRESS AND RELEASE BUTTON SW2 UNTIL YOU HAVE EXITED ALL MENUS

REF. NO.	PART NO.	DESCRIPTION	REQ. NO.
1	PEO366	Light Module - Green - Steady 12 VDC	1
2	PEO368	Light Module - Amber - Flashing 12 VDC	1
3	PEO367	Light Module - Red - Steady 12 VDC	1
4	PEO360	Pole Mount Base	
	PEO369	Single Tone Sound Module (not shown) (Optional) 12 VDC	
	PEO370	Incandescent Lamp (not shown) (replacement) 12 VDC	

## TILT-A-WAY DCM ELECTROMAGNETIC LOCK

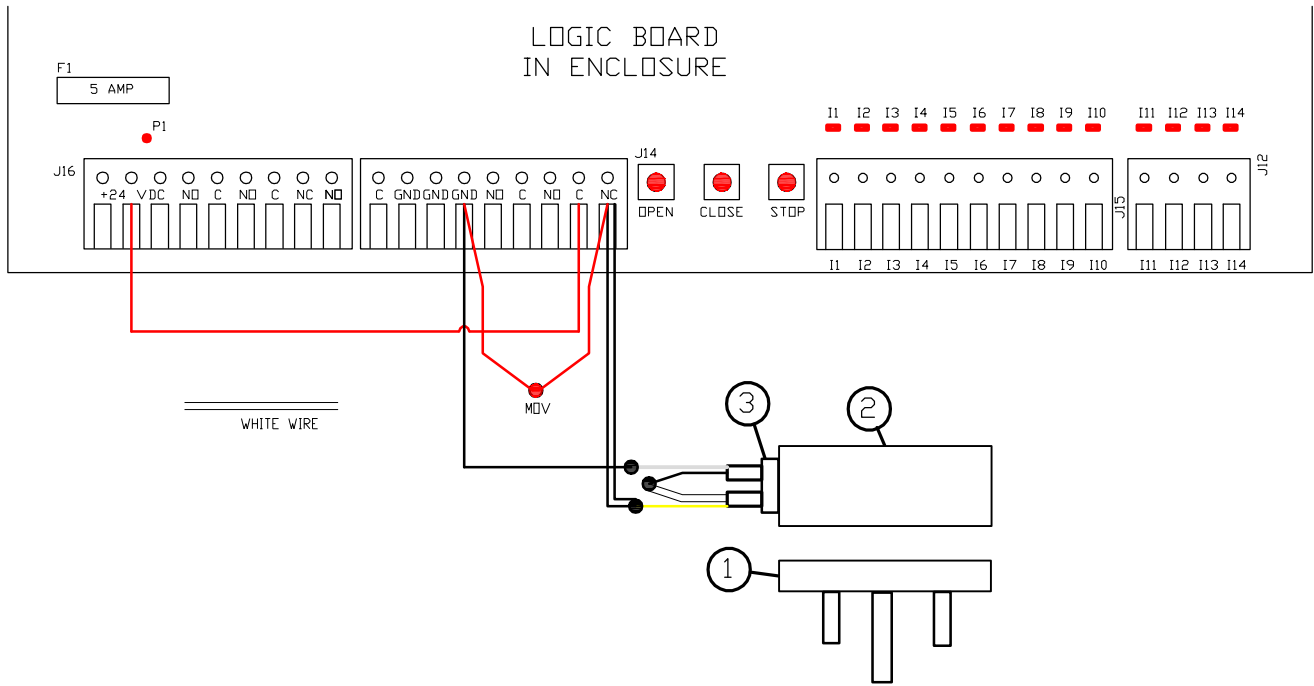

THE ELECTROMAGNETIC LOCK IS CONNECTED TO AUXILIARY OUTPUT RELAY # 3  
 THE AUXILIARY OUTPUT RELAY NEEDS TO BE SET TO UNLOCK PULSE  
 PRESS AND HOLD BUTTON SW2 ON THE INTERFACE BOARD UNTIL THE DISPLAY CHANGES  
 RELEASE THE SW2 BUTTON AND THE DISPLAY WILL SHOW

### MAIN MENU

**UP / DOWN - VIEW MENUS**

**SELECT - VIEW / EDIT**

**RESET - EXIT**

PRESS AND RELEASE BUTTON SW4 UNTIL THE DISPLAY SHOWS

### TIMING AND OPTIONS

PRESS AND RELEASE BUTTON SW1 TO ENTER THE MENU

PRESS AND RELEASE BUTTON SW4 UNTIL THE DISPLAY SHOWS

### AUXILIARY 1 / O

PRESS AND RELEASE BUTTON SW1 TO ENTER THE SUBMENU

PRESS AND RELEASE BUTTON SW4 UNTIL THE DISPLAY SHOWS

### AUXILIARY OUTPUT # 3 FUNCTION

PRESS AND RELEASE BUTTON SW1 TO ENTER THE SUBMENU

PRESS AND RELEASE BUTTON SW4 UNTIL THE DISPLAY SHOWS

### UNLOCK PULSE

PRESS AND RELEASE BUTTON SW1 TO SAVE SELECTION

PRESS AND RELEASE BUTTON SW2 UNTIL YOU HAVE EXITED ALL MENUS

REF NO.	PART NO.	DESCRIPTION	REQ NO
1	PEO277	Electromagnetic Armature (Located stationary at outer end of barrier or at outer end of an opposite barrier)	1
2	PEO277	Electromagnetic Lock ( Located at outer end of barrier 24 VDC)	1
3	PEO246	1/2" Strain Relief Fitting (one at barrier lower pipe)	1

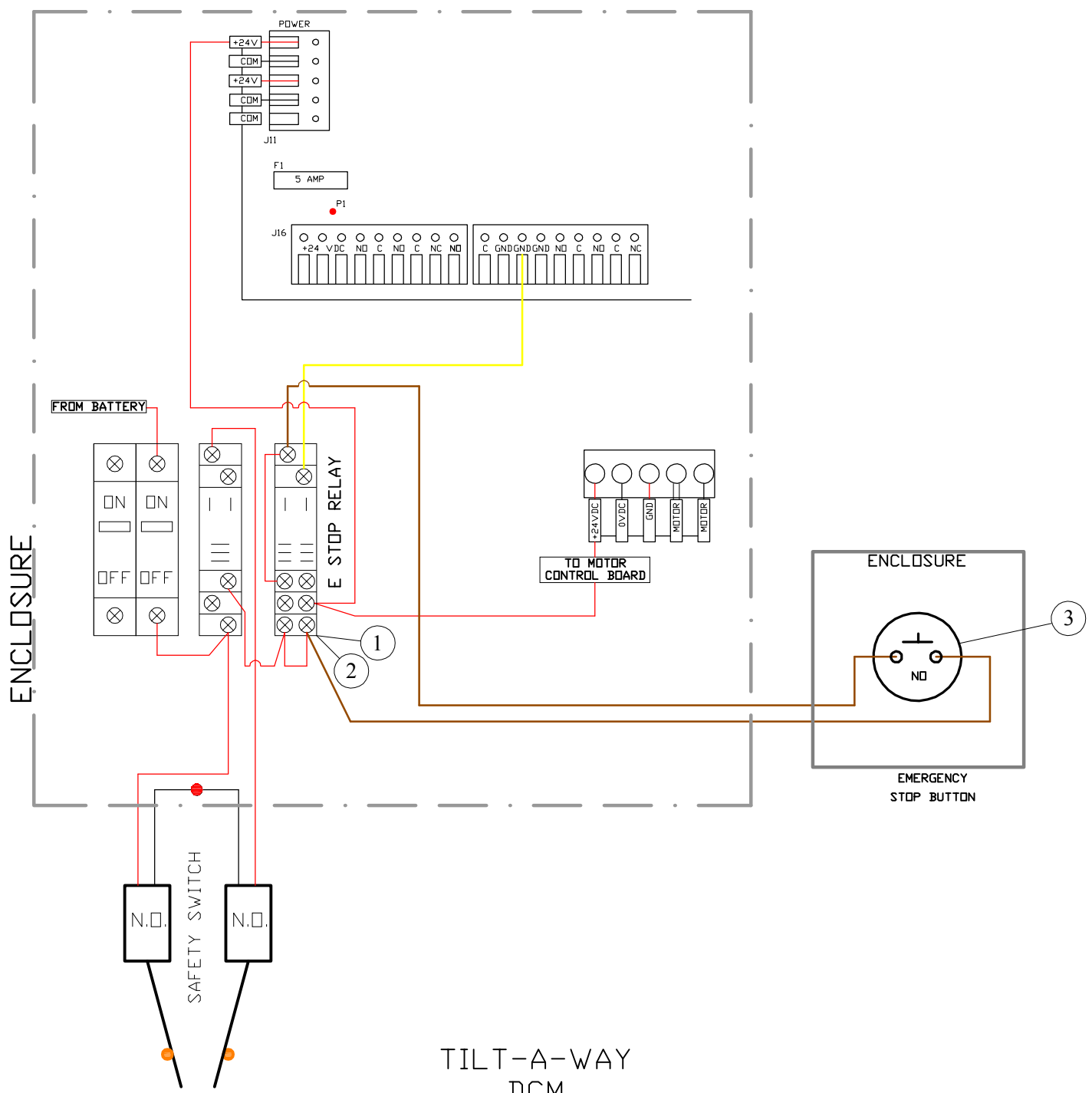

REF. NO.	PART NO.	DESCRIPTION	REQ. NO.
1	PEO678	Relay (not shown)	1
2	PEO606A	Socket, Relay	1
3	PEO257	Emergency Stop Button	1

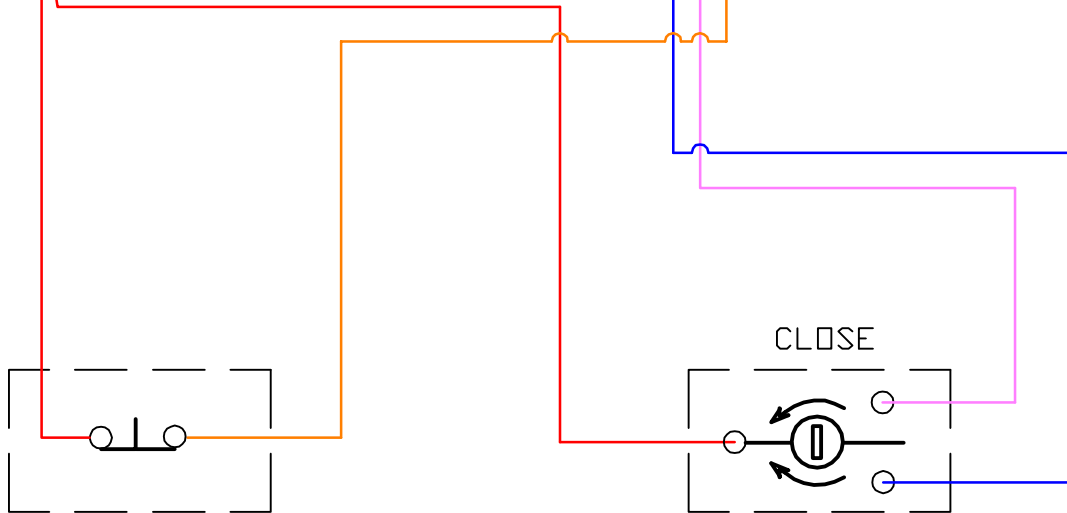
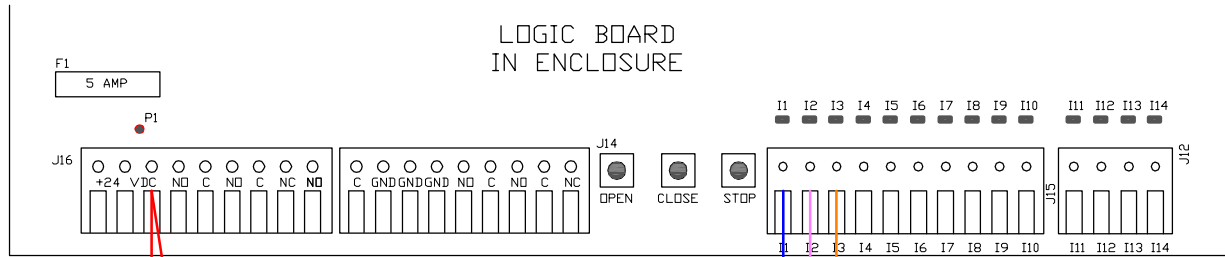

STOP  
STOP P.B.  
IF OTHER PUSH BUTTON  
STATIONS ARE BEING USED,  
WIRE IN SERIES

CLOSE  
OPEN  
MANUAL  
KEY SWITCH

**TILT-A-WAY DCM  
MANUAL KEY SWITCH**

PART NO	DESCRIPTION	REQ NO
PE0263	Manual Key Switch	as req'd

# TILT-A-WAY DCM GATE OPEN HORN AND LIGHT INDICATOR

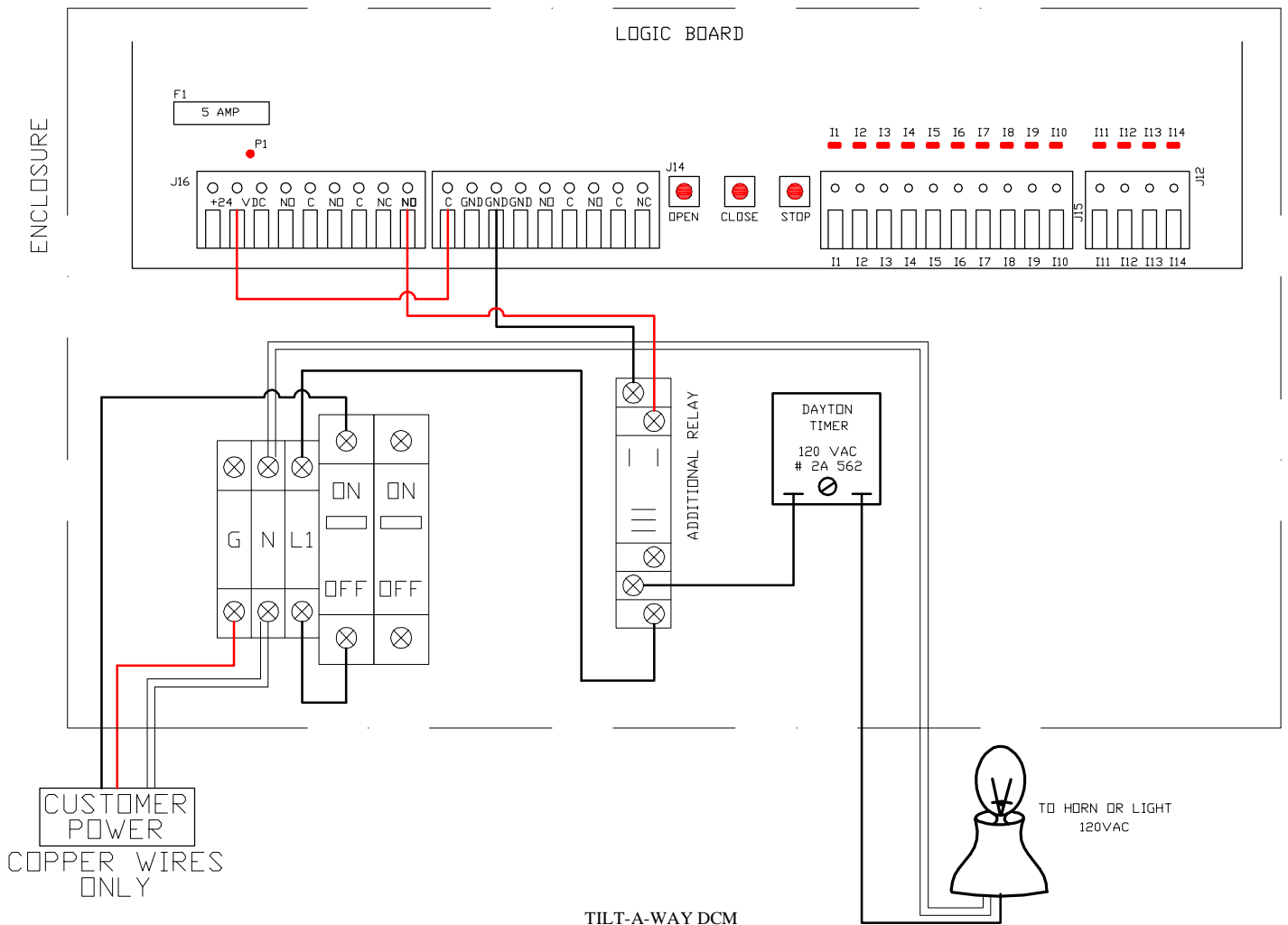

TILT-A-WAY DCM  
THE ADDITIONAL RELAY IS CONNECTED TO THE NORMALLY OPEN CONTACTS OF AUXILIARY OUTPUT # 1  
THE OUTPUT FUNCTIONS FOR AUXILIARY OUTPUT # 1 WILL NEED TO BE SET AS FOLLOVED  
PRESS AND HOLD BUTTON SW2 ON THE INTERFACE BOARD UNTIL THE DISPLAY CHANGES  
RELEASE THE SW2 BUTTON AND THE DISPLAY WILL SHOW

**MAIN MENU**  
**UP / DOWN - VIEW MENUS**  
**SELECT - VIEW / EDIT**  
**RESET - EXIT**

PRESS AND RELEASE BUTTON SW4 UNTIL THE DISPLAY SHOWS

**TIMING AND OPTIONS**

PRESS AND RELEASE BUTTON SW1 TO ENTER THE MENU  
PRESS AND RELEASE BUTTON SW4 UNTIL THE DISPLAY SHOWS

**AUXILIARY I / O**

PRESS AND RELEASE BUTTON SW1 TO ENTER THE SUBMENU  
PRESS AND RELEASE BUTTON SW4 UNTIL THE DISPLAY SHOWS

**AUXILIARY OUTPUT # 1 FUNCTION**

PRESS AND RELEASE BUTTON SW1 TO ENTER THE SUBMENU  
PRESS AND RELEASE BUTTON SW4 UNTIL THE DISPLAY SHOWS

**HOLD AUX RELAY ON CLOSE LIMIT SWITCH**

PRESS AND RELEASE BUTTON SW1 TO SAVE SELECTION  
PRESS AND RELEASE BUTTON SW2 UNTIL YOU HAVE EXITED ALL MENUS

REF NO.	PART NO.	DESCRIPTION	REQ NO
1	PEO284	Delay Timer	1
2	PEO605A	Socket, Relay	1
3	PEO679	Relay	1
		Vehicle Indicator Light ( supplied by customer)	

DUAL HEIGHT PEDESTAL

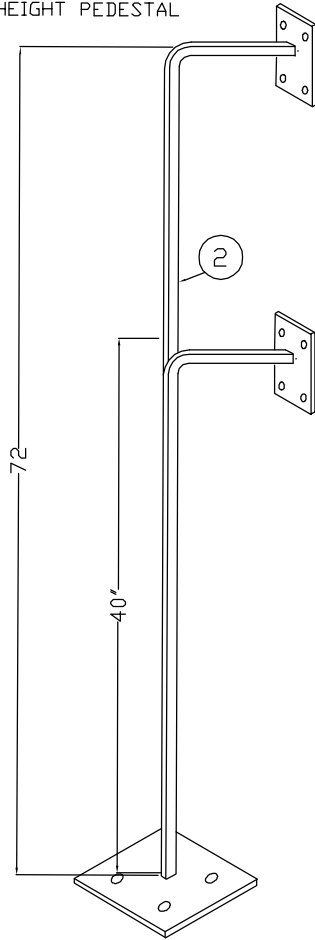

SINGLE HEIGHT PEDESTAL

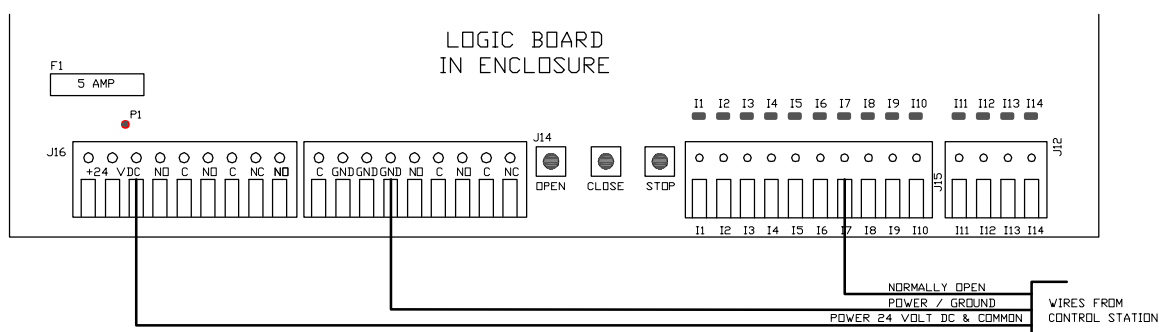
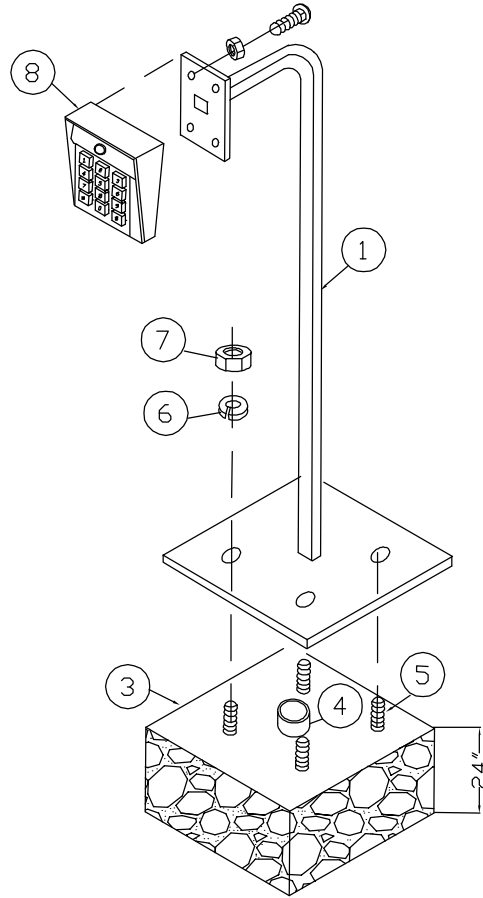

NOTE: INPUT TO TERMINAL 17 FROM THE CONTROL STATION MUST BE 24 VOLT DC POSITIVE

TILT-A-WAY DCM  
REMOTE CONTROL STATION PEDESTAL AND GATELOCK

REF NO.	PART NO.	DESCRIPTION	REQ NO
1	N/A	Single Height Pedestal	1
2	N/A	Dual Height Pedestal 72" in Height	1
3	N/A	Concrete Support Pier 15" X 15" X 24" Deep	1
4	N/A	1" in Diameter Electrical Conduit with 2 1/2" projection above Concrete. Conduit Routed from Barrier Pedestal.	1
5	N/A	1/2" x 8" Expansion Bolt	4
6	NA	1/2" Lock Washer	4
7	N/A	1/2" Hex Nut	4
8	N/A	Remote Control Station of Choice (Included are bolts, nuts, keys and plate.	4



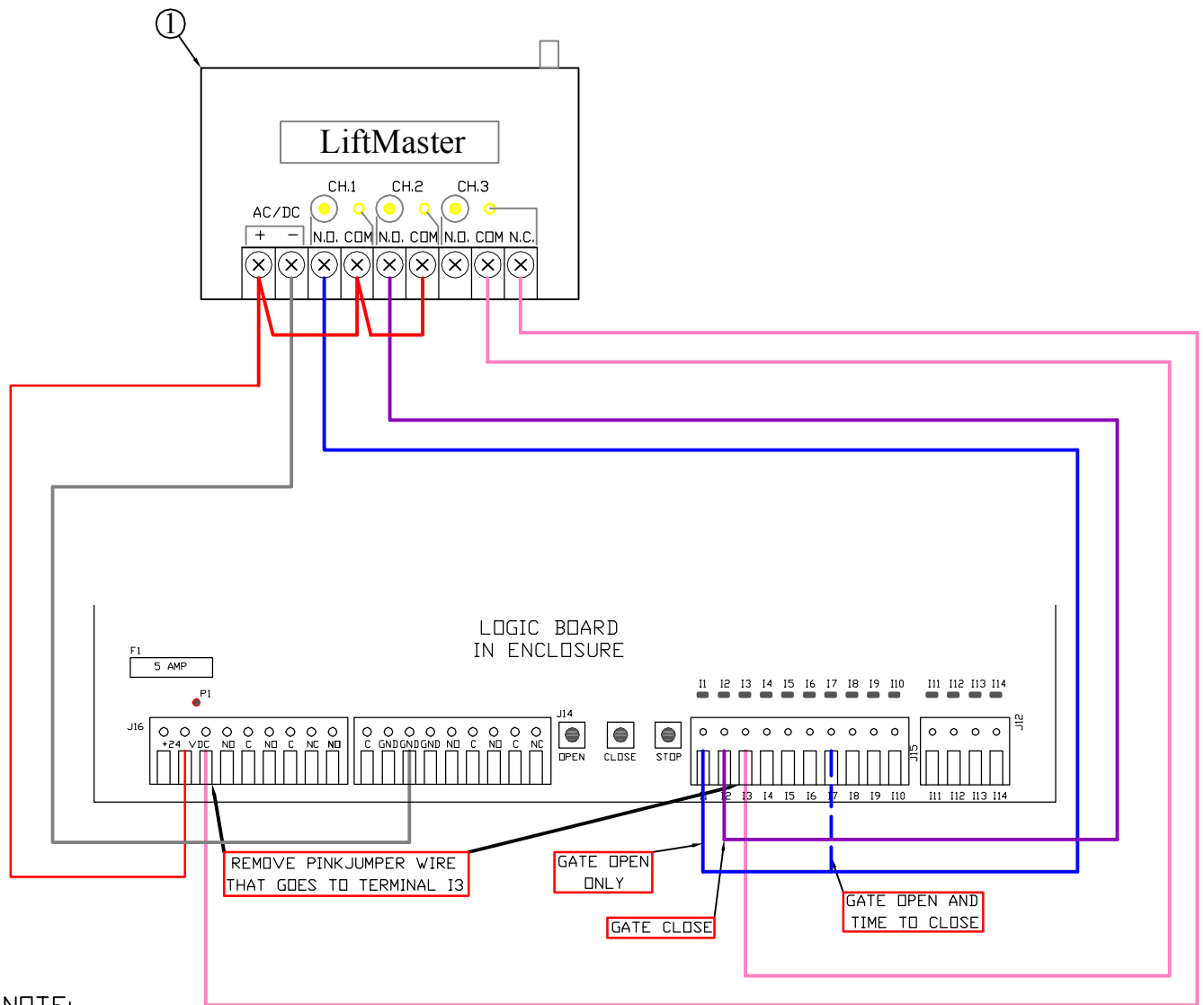

**NOTE:**

ALL STOP CONNECTIONS IN SERIES

STOP CIRCUIT  
ALL STOPS  
MUST BE  
WIRED IN  
SERIES

**TILT-A-WAY DCM  
RADIO RECEIVER - THREE BUTTON**

REF. NO.	PART NO.	DESCRIPTION	REQ. NO.
1	PEO272	Radio Receiver Model 850LM	1
2	PEO273A	Radio Transmitter 1-Button Model 811LM	as req
3	PEO273B	Radio Transmitter 3-Button Model 813LM	as req
1	G00131	Radio Receiver Mounting Plate (not shown)	1

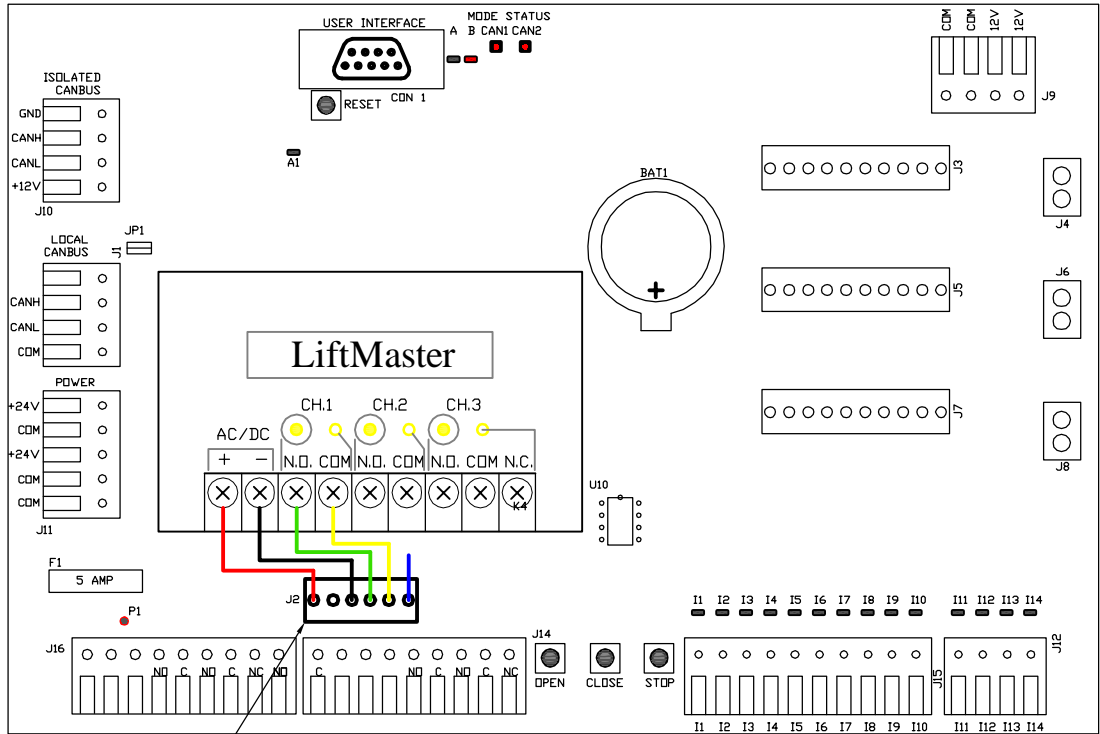

MOUNT TO LOGIC BOARD  
 USING STAND OFFS  
 CUT RED, BLACK, GREEN,  
 AND YELLOW WIRES CLOSE TO  
 WHITE PLUG END.  
 TRIM AND WIRE AS SHOWN.  
 CUT BLUE WIRE CLOSE  
 TO LOGIC BOARD.

### TILT-A-WAY DCM RADIO RECEIVER - SINGLE BUTTON

REF. NO.	PART NO.	DESCRIPTION	REQ. NO.
1	PEO272	Radio Receiver Model 850LM	1
2	PEO273A	Radio Transmitter 1-Button Model 811LM	as req
3	PEO273B	Radio Transmitter 3-Button Model 813LM	as req
4	G00131	Radio Receiver Mouting Plate (not shown)	1

### APPLICATION

The receiver can be used as a single or three channel receiver to control up to 3 gates or commercial door operators. The receiver can also be used with a 3-button remote control to operate the OPEN, CLOSE, and STOP feature on a commercial door operator. The receiver is not for use with MyQ™ enabled garage door openers or devices.

Each channel is compatible with a certain number of remote controls and keypads. Refer to the list below:

- CH1: 50 remote controls and 2 keypads
- CH2: 20 remote controls and 2 keypads
- CH3: 20 remote controls and 2 keypads

When the channel has reached full capacity for remote controls, all LEDs will blink 3 times. When the channel has reached full capacity for keypads, all LEDs will blink 4 times. Additional accessories can be programmed, however, the newly programmed accessory will replace the first programmed accessory.

**NOTE:** The receiver will only allow you to program a button on the remote control to one channel at a time. For example, if the button on the remote control is already programmed to channel 1 and then is programmed to channel 3, the button will be erased from channel 1 and will only work on channel 3.

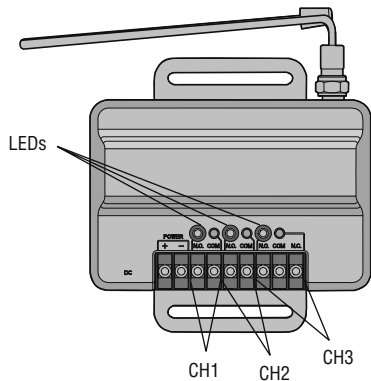

### INSTALLATION

The receiver and antenna use TV Type F coaxial connectors. The antenna can be connected directly to the receiver or it can be installed remotely using a coaxial cable extension kit (Model 86LM, 15 ft. or 86LMT, 25 ft.).

- 1 Select a location for the receiver which allows access to the terminals and space for the antenna. Ensure antenna does not touch metal surfaces. DO NOT bend or fold the antenna.
- 2 Fasten the receiver securely with the hook and loop fasteners (provided) or screws (not provided).
- 3 After installation is complete, connect power. You may use 85LM plug-in or 95LM wired-in transformer, or power provided from your operator (9-30 V AC, 9-34 Vdc or see power ratings on next page).  
**NOTE:** The receiver can command the operator to close the door or gate by constant pressure. This feature is only available with a wireless control panel (Model 885LM). To enable this feature, press and hold the push bar until the gate or garage door moves to the closed position.

### ⚡ ⚠ WARNING

- To prevent possible SERIOUS INJURY or DEATH from electrocution:
- Be sure power is NOT connected BEFORE installing the receiver.
- To prevent possible SERIOUS INJURY or DEATH from a moving gate or garage door:
- ALWAYS keep remote controls out of reach of children. NEVER permit children to operate, or play with remote control transmitters.
  - Activate gate or door ONLY when it can be seen clearly, is properly adjusted, and there are no obstructions to door travel.
  - ALWAYS keep gate or garage door in sight until completely closed. NEVER permit anyone to cross path of moving gate or door.

### ⚠ WARNING

To prevent possible SERIOUS INJURY or DEATH, the use of CONSTANT OPERATION on residential openers is PROHIBITED. When a receiver is used to activate a commercial door opener, a reversing edge MUST be installed on the bottom of the door. Failure to install a reversing edge under these circumstances may result in SERIOUS INJURY or DEATH to persons trapped beneath the door.

### WIRING

Refer to your commercial door operator or gate operator owner manual or wiring diagrams for specific wiring information.

#### SINGLE CHANNEL

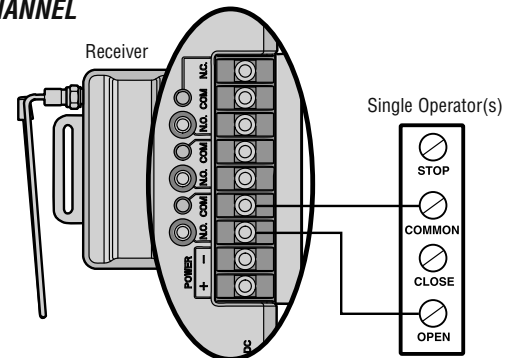

#### THREE CHANNEL

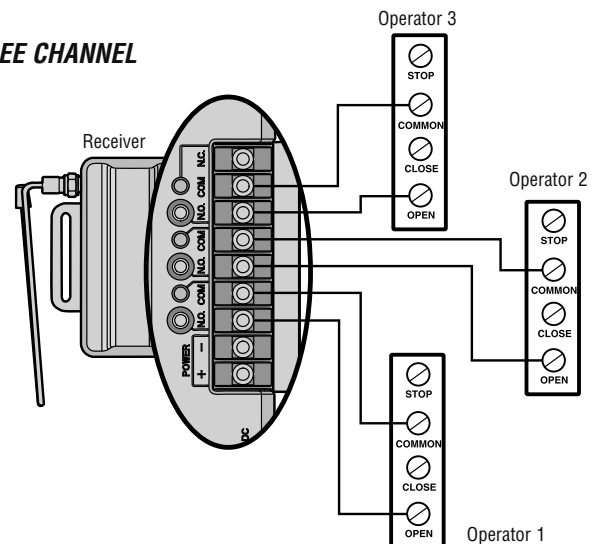

# WIRING CONTINUED

**OPEN, CLOSE, STOP**

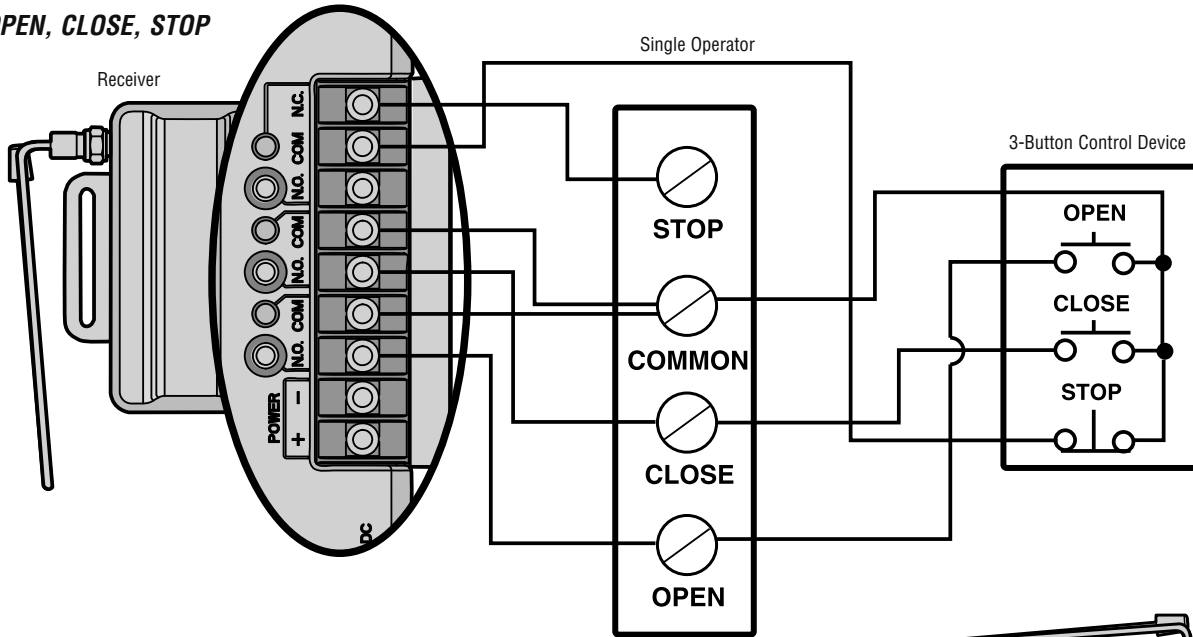

Refer to your commercial door operator or gate operator wiring diagrams for instructions on connecting two or more 3-Button control devices.

## PROGRAMMING

### PROGRAM A SINGLE BUTTON REMOTE CONTROL

- 1 Press and release the Learn button for the selected channel on the receiver. The corresponding LED will glow steadily for 30 seconds.
- 2 Within 30 seconds press and hold the button on the remote control that you wish to program to the receiver.
- 3 Release the remote control button when the LED on the receiver blinks, then turns off. Programming is complete.

Repeat the steps above for each remote control you would like to program.

### PROGRAM A 3-BUTTON REMOTE CONTROL AS OPEN, CLOSE, AND STOP

- 1 Press and release the CH1 Learn button on the receiver.
- 2 Within 30 seconds press the desired OPEN button on the remote control.
- 3 Press and release the CH2 Learn button on the receiver.
- 4 Within 30 seconds press the desired CLOSE button on the remote control.
- 5 Press and release the CH3 Learn button on the receiver.
- 6 Within 30 seconds press the desired STOP button on the remote control.

**NOTE:** If a remote control button is not pressed within 30 seconds, the LED next to the selected Learn button will turn OFF. In that case, repeat the programming.

### TO ERASE THE MEMORY

- 1 Press and hold the Learn button for the channel you want to erase. Release the button when the corresponding LED turns off; the memory has been erased.

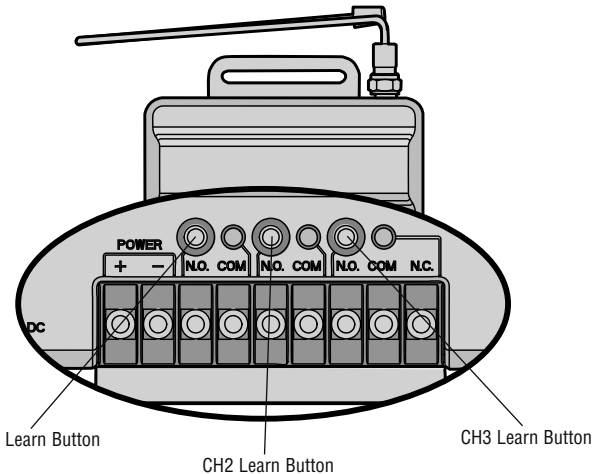

### SPECIFICATIONS

Contact Rating . . . . . 5 Amps 28 Vac or dc Max.  
 Power. . . . . 9-30V AC or 9-34V DC, 50mA, 60Hz  
 RF Frequency: . . . . . 310, 315, and 390 MHz

**NOTE:** If your operator does not meet the power specifications you will need a transformer (Model 85LM plug-in or 95LM wired-in).

### COMPATIBLE ACCESSORIES

Remote Controls . . . . . Models 811LM, 813LM, 891LM, 893LM, 890MAX, 893MAX, 895MAX, 892LT, 894LT  
 Keypads . . . . . Models 877LM, 877MAX  
 Antenna Extension Kits . . . . . Models 86LM, 86LMT  
 Antenna Only . . . . . K77-36541

**NOTICE:** To comply with FCC and/or Industry Canada (IC) rules, adjustment or modifications of this receiver are prohibited. THERE ARE NO USER SERVICEABLE PARTS.  
 This device complies with Part 15 of the FCC rules and IC RSS-210. Operation is subject to the following two conditions: (1) this device may not cause harmful interference, and (2) this device must accept any interference received, including interference that may cause undesired operation.

**FOR TECHNICAL SUPPORT DIAL OUR TOLL FREE NUMBER:**

**1-800-528-2806**

### UTILISATION

Cet appareil peut s'utiliser comme récepteur à un ou trois canaux de manière à commander jusqu'à trois ouvre-porte ou ouvre-portail commerciaux. Il peut aussi s'utiliser avec une télécommande à 3 boutons pour actionner les fonctions **OUVERTURE**, **FERMETURE** et **ARRÊT** d'un ouvre-porte commercial. Il n'est pas conçu pour fonctionner avec les ouvre-porte et autres appareils compatibles MyQ™.

Chaque canal est compatible avec un certain nombre de télécommandes et de claviers comme indiqué ci-dessous :

- Canal 1 : 50 télécommandes et 2 claviers
- Canal 2 : 20 télécommandes et 2 claviers
- Canal 3 : 20 télécommandes et 2 claviers

Lorsque le canal a atteint la pleine capacité des télécommandes, tous les témoins DEL clignotent trois fois. Lorsque le canal a atteint la pleine capacité des claviers, tous les témoins DEL clignotent quatre fois. On peut programmer des accessoires supplémentaires; toutefois, l'accessoire nouvellement programmé remplacera celui qui a été programmé en premier.

**REMARQUE :** Le récepteur ne vous permet de programmer un bouton de télécommande que pour un seul canal à la fois. Par exemple, si le bouton de la télécommande est déjà programmé pour le canal 1, puis pour le canal 3, il sera effacé du canal 1 et ne fonctionnera que sur le canal 3.

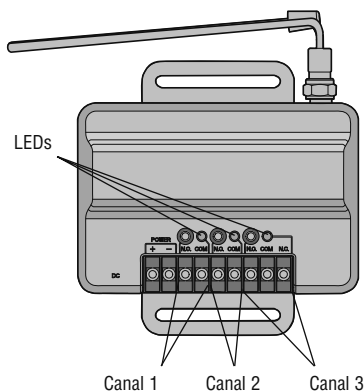

### INSTALLATION

Le récepteur et l'antenne utilisent des connecteurs coaxiaux de type F. L'antenne peut être connectée directement au récepteur ou installée à distance avec une rallonge coaxiale modèle 86LM (4,57 m) ou 86LMT (7,62 m).

- 1 Choisir pour installer le récepteur un emplacement permettant d'accéder aux bornes et laissant assez d'espace pour l'antenne. S'assurer que l'antenne ne touche pas de surfaces métalliques. NE PAS plier ou courber l'antenne.
- 2 Fixer solidement le récepteur avec les bandes auto-agrippantes (fournies) ou avec des vis (non fournies).
- 3 Une fois l'installation terminée, branchez le cordon d'alimentation. Vous pouvez utiliser un transformateur 85LM à prise ou 95LM à câble, ou alimenté par votre opérateur (9-30 V c.a., 9-34 V c.c. ou consultez les régimes d'alimentation à la page suivante).

**REMARQUE :** Le récepteur peut commander à l'opérateur de fermer la porte ou le portail par une pression constante. Cette fonction est uniquement disponible avec un panneau de commande sans fil (modèle 885LM). Pour activer cette fonction, appuyez sur la barre de poussée et gardez-la enfoncée jusqu'à ce que le portail ou la porte de garage se déplace vers la position fermée.

### ⚠️ AVERTISSEMENT

Pour prévenir le risque de BLESSURES GRAVES ou de DÉCÈS par électrocution :

- S'assurer que l'alimentation n'est PAS branchée AVANT d'installer le récepteur.

Pour prévenir le risque de BLESSURES GRAVES ou de DÉCÈS causés par un portail ou une porte de garage en mouvement :

- TOUJOURS tenir les télécommandes hors de portée des enfants. Ne JAMAIS laisser un enfant utiliser une télécommande ou jouer avec.
- Actionner la porte ou le portail UNIQUEMENT lorsqu'ils sont bien visibles et bien ajustés et que rien ne fait obstacle à leur mouvement.
- TOUJOURS surveiller du regard le portail ou la porte de garage jusqu'à sa fermeture complète. Ne JAMAIS laisser personne franchir une porte ou un portail en mouvement.

### ⚠️ AVERTISSEMENT

Pour prévenir le risque de BLESSURES GRAVES ou de DÉCÈS, il est INTERDIT d'utiliser les ouvre-porte résidentiels EN FONCTIONNEMENT CONTINUËL.

Avant d'utiliser un récepteur pour actionner un ouvre-porte commercial, il est IMPÉRATIF d'installer une tranche de sécurité (barre palpeuse) au bas de la porte. L'absence de tranche de sécurité convenablement installée peut entraîner des BLESSURES GRAVES ou un DÉCÈS si quelqu'un se retrouve coincé sous la porte.

### CÂBLAGE

Pour obtenir des informations précises sur le câblage, consulter la notice ou les schémas de câblage de l'ouvre-porte ou ouvre-portail.

#### UN CANAL

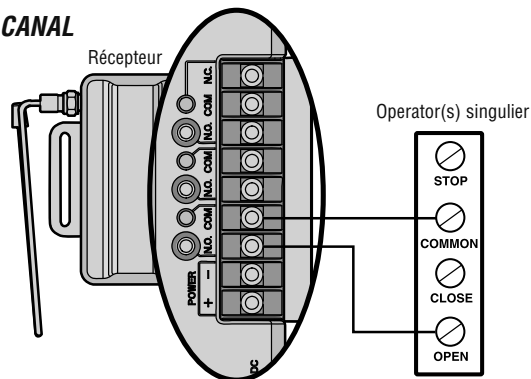

#### TROIS CANAL

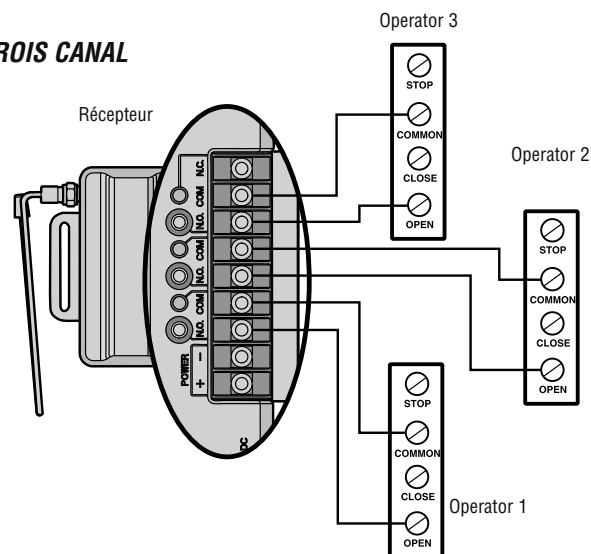

## CÂBLAGE (SUITE)

OUVERTURE, FERMETURE,  
ARRÊT

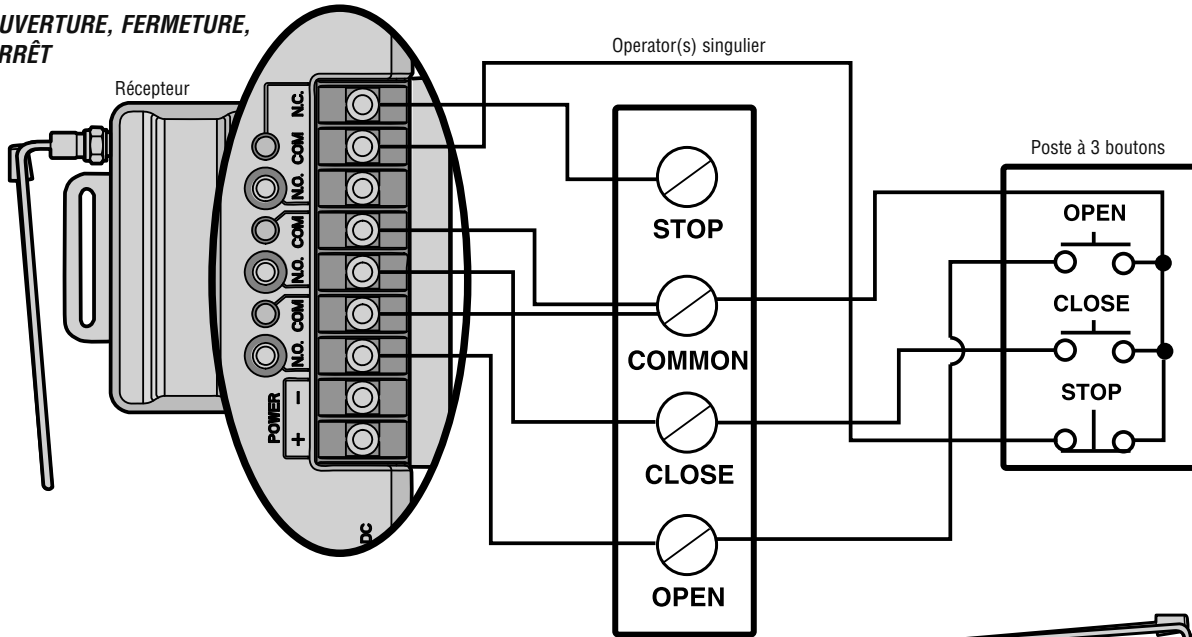

Consulter les schémas de câblage de l'ouvre-porte ou de l'ouvre-portail pour obtenir des instructions sur la connexion de deux ou plusieurs télécommandes à 3 boutons.

## PROGRAMMATION

### PROGRAMACIÓN DE UN CONTROL REMOTO DE 1 BOTÓN

- 1 Presser et relâcher le bouton de programmation du canal sélectionné sur le récepteur. Le témoin correspondant s'allume et reste allumé pendant 30 secondes.
- 2 Dans les 30 secondes, presser et maintenir enfoncé le bouton de la télécommande à programmer pour ce récepteur.
- 3 Le témoin du récepteur se met à clignoter, puis s'éteint. Relâcher alors le bouton de la télécommande. La programmation est terminée.

Répéter les étapes ci-dessus pour chaque télécommande à programmer.

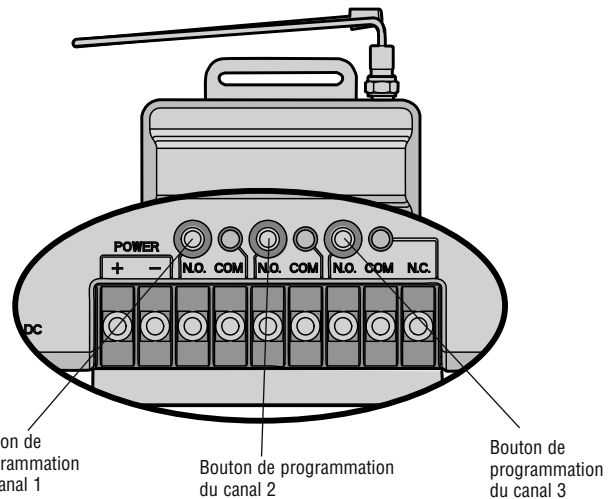

### PROGRAMMATION DES FONCTIONS OUVERTURE, FERMETURE ET ARRÊT D'UNE TÉLÉCOMMANDE À 3 BOUTONS

- 1 Presser et relâcher le bouton de programmation du canal 1 sur le récepteur.
- 2 Dans les 30 secondes, appuyer sur le bouton d'ouverture souhaité sur la télécommande.
- 3 Presser et relâcher le bouton de programmation du canal 2 sur le récepteur.
- 4 Dans les 30 secondes, appuyer sur le bouton de fermeture souhaité sur la télécommande.
- 5 Presser et relâcher le bouton de programmation du canal 3 du récepteur.
- 6 Dans les 30 secondes, appuyer sur le bouton d'arrêt souhaité sur la télécommande.

**REMARQUE :** Si aucun bouton de la télécommande n'est enfoncé dans les 30 secondes, le témoin du bouton de programmation sélectionné s'éteint. Dans ce cas, recommencer la programmation.

### POUR EFFACER LA MÉMOIRE

- 1 Presser et maintenir enfoncé le bouton de programmation du canal à effacer. Relâcher le bouton lorsque le témoin correspondant s'éteint. La mémoire est alors effacée.

### CARACTÉRISTIQUES TECHNIQUES

Régime de contact . . . . . 5 A, 28 V (c.a. ou c.c.) max.  
Alimentation . . . . . 9 à 30 V c.a. ou 9 à 34 V c.c., 50 mA, 60 Hz  
Fréquences radio . . . . . 310, 315 et 390 MHz

**REMARQUE :** Si l'ouvre-porte ou l'ouvre-portail ne répond pas à ces spécifications électriques, il est nécessaire d'utiliser un transformateur modèle 85LM (à fiche de branchement) ou 95LM (à câblage direct).

### ACCESSOIRES COMPATIBLES

Télécommandes . . Modèles 811LM, 813LM, 891LM, 893LM, 890MAX, 893MAX, 895MAX, 892LT, 894LT  
Claviers . . . . . Modèles 877LM, 877MAX  
Rallonges d'antenne . . . . . Modèles 86LM, 86LMT  
Antenne seule . . . . . K77-36541

AVIS : Conformément aux règlements de la FCC et d'Industrie Canada, il est interdit de modifier ce récepteur ou ses réglages d'origine. CET APPAREIL NE COMPORTE AUCUNE PIÈCE POUVANT ÊTRE RÉPARÉE PAR L'UTILISATEUR.

Cet appareil est conforme à la partie 15 des règlements de la FCC et à la norme RSS-210 d'Industrie Canada. Son utilisation est subordonnée aux deux conditions suivantes : (1) l'appareil ne doit pas causer d'interférences nuisibles et (2) l'appareil doit accepter toute interférence reçue, y compris celles qui pourraient un fonctionnement indésirable.

**POUR L'ASSISTANCE TECHNIQUE, APPELER LE NUMÉRO SANS FRAIS SUIVANT :**

**1-800-528-2806**

© 2011, The Chamberlain Group, Inc.  
All Rights Reserved  
Tous droits réservés

### Introduction

This product is for use with models 850LM and 860LM universal receivers as well as any Security+ 2.0™ compatible LiftMaster gate operators. Depending on the receiver channel, you may program up to 20 or 50 remote control dip switch configurations to your receiver. To exceed the 20/50 limit, match the dip switches in the new remote control to the dip switches in an existing remote control.



811LM



813LM

### WARNING

To prevent possible **SERIOUS INJURY** or **DEATH** from a moving gate or garage door:

- ALWAYS keep remote controls out of reach of children. NEVER permit children to operate, or play with remote control transmitters.
- Activate gate or door ONLY when it can be seen clearly, is properly adjusted, and there are no obstructions to door travel.
- ALWAYS keep gate or garage door in sight until completely closed. NEVER permit anyone to cross path of moving gate or door.

### Set the Dip Switches

- 1 Slide the cover open to access the dip switches in the remote control.
- 2 Use a pen or screwdriver to slide the dip switches to any position you want (ON or OFF).

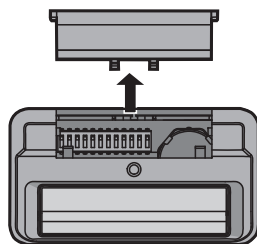

### Programming

- 1 Press and release the Learn button for the selected channel on the receiver. The corresponding LED will glow steadily for 30 seconds.
- 2 Within 30 seconds press and hold the button on the remote control that you wish to program to the receiver.
- 3 Release the remote control button when the LED on the receiver blinks, then turns off. Programming is complete.

Repeat the steps above for each remote control you would like to program.

If you would like to program an 813LM as an OPEN, CLOSE, STOP, refer to the 850LM receiver manual.

For programming to the 860LM receiver or to a Security+ 2.0™ compatible gate operator, please refer to the receiver/operator instructions manual for location of the learn button(s).

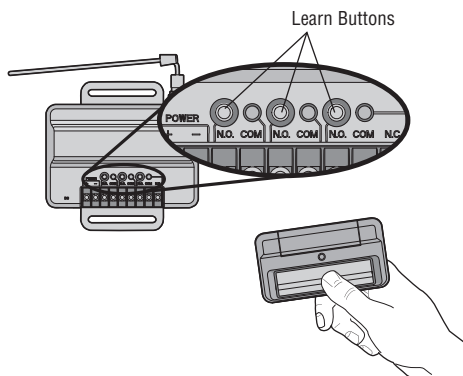

## The Remote Control Battery

The 3 volt battery should produce power for 1 year. Dispose of old batteries properly.

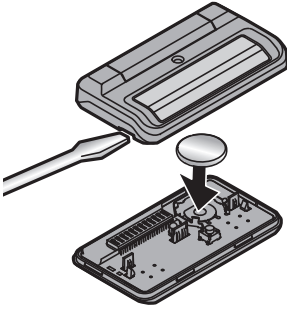

## **WARNING**

To prevent possible **SERIOUS INJURY** or **DEATH**:

- NEVER allow small children near batteries.
- If battery is swallowed, immediately notify doctor.

**NOTICE:** To comply with FCC and/or Industry Canada (IC) rules, adjustment or modifications of this transceiver are prohibited. THERE ARE NO USER SERVICEABLE PARTS.

This device complies with Part 15 of the FCC rules and IC RSS-210. Operation is subject to the following two conditions: (1) this device may not cause harmful interference, and (2) this device must accept any interference received, including interference that may cause undesired operation.

## Replacement Parts

Visor Clip .....	29C137
3V Battery .....	10A20

**FOR TECHNICAL SUPPORT DIAL OUR TOLL FREE NUMBER:**

**1-800-528-9131**

[www.liftmaster.com](http://www.liftmaster.com)



### Introduction

Cet article est utilisé avec les récepteurs universels modèles 850LM et 860LM, ainsi qu'avec toute commande de barrière LiftMaster compatible au Security+ 2.0™. Selon le canal de réception, vous pouvez programmer de 20 à 50 configurations de commutateurs DIP de télécommande sur votre récepteur. Pour dépasser la limite 20/50, appariez les commutateurs DIP de la nouvelle télécommande aux commutateurs DIP de la télécommande existante.



811LM



813LM

### **!** AVERTISSEMENT

Afin d'éliminer les risques de BLESSURES GRAVES ou de MORT découlant de l'actionnement d'une clôture ou d'une porte de garage :

- TOUJOURS garder les télécommandes hors de la portée des enfants. NE JAMAIS laisser un enfant manipuler une télécommande ni jouer avec elle.
- Actionner la clôture ou la porte UNIQUEMENT lorsqu'elle est clairement visible, correctement ajustée et que le mécanisme est libre de toute entrave.
- TOUJOURS garder la clôture ou la porte de garage en vue jusqu'à sa fermeture complète. NE permettez à quiconque de passer lorsqu'une clôture ou une porte est en mouvement.

### Réglage des commutateurs DIP

- 1 Ouvrez le couvercle en le faisant glisser pour avoir accès aux commutateurs DIP de la télécommande.
- 2 À l'aide d'une plume ou d'un tournevis, glissez les commutateurs DIP à la position souhaitée (ON ou OFF).

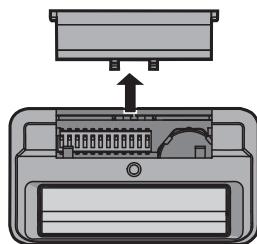

### Programmation

- 1 Pressez puis relâchez le bouton Learn du canal sélectionné sur le récepteur. Le voyant DEL correspondant reste allumé pendant 30 secondes.
- 2 Dans les 30 secondes, pressez et maintenez le bouton de la télécommande que vous voulez programmer sur le récepteur.
- 3 Relâchez le bouton de la télécommande lorsque le voyant DEL du récepteur clignote, puis s'éteint. La programmation est terminée.

Reprenez les étapes précédentes avec chaque télécommande que vous souhaitez programmer.

Reportez-vous au manuel du récepteur 850LM si vous souhaitez programmer les fonctions OPEN, CLOSE, STOP (ouverture, fermeture, arrêt) sur un 813LM.

Pour programmer sur le récepteur 860LM ou un dispositif de commande compatible à un Security+ 2.0™, reportez-vous au manuel d'instructions récepteur/dispositif de commande pour l'emplacement du/des bouton(s) Learn.

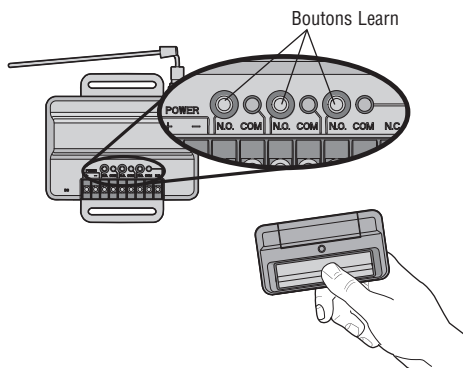

## La pile de télécommande

La pile de 3 V devrait produire suffisamment de puissance pour au moins un an. Se débarrasser des vieilles piles convenablement.

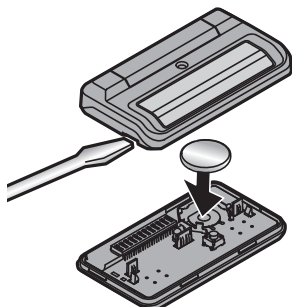

## **!** AVERTISSEMENT

Pour prévenir d'éventuelles BLESSURES GRAVES ou la MORT :

- Ne JAMAIS laisser de petits enfants à proximité des piles.
- Aviser immédiatement un médecin en cas d'ingestion de la pile.

AVIS : Les règles de la FCC et/ou d'Industrie Canada (IC) interdisent tout ajustement ou toute modification de ce récepteur. IL N'EXISTE AUCUNE PIÈCE SUSCEPTIBLE D'ÊTRE ENTRETENUE PAR L'UTILISATEUR.

Cet appareil est conforme aux dispositions de la partie 15 du règlement de la FCC et de la norme IC RSS-210. Son utilisation est assujettie aux deux conditions suivantes : (1) ce dispositif ne peut causer des interférences nuisibles, et (2) ce dispositif doit accepter toute interférence reçue, y compris une interférence pouvant causer un fonctionnement non souhaité.

## Pièces de rechange

Pince du pare-soleil .....	29C137
Pile de 3V .....	10A20

**POUR OBTENIR DE L'ASSISTANCE TECHNIQUE, COMPOSER NOTRE NUMÉRO GRATUIT :**

**1-800-528-9131**

**[www.liftmaster.com](http://www.liftmaster.com)**

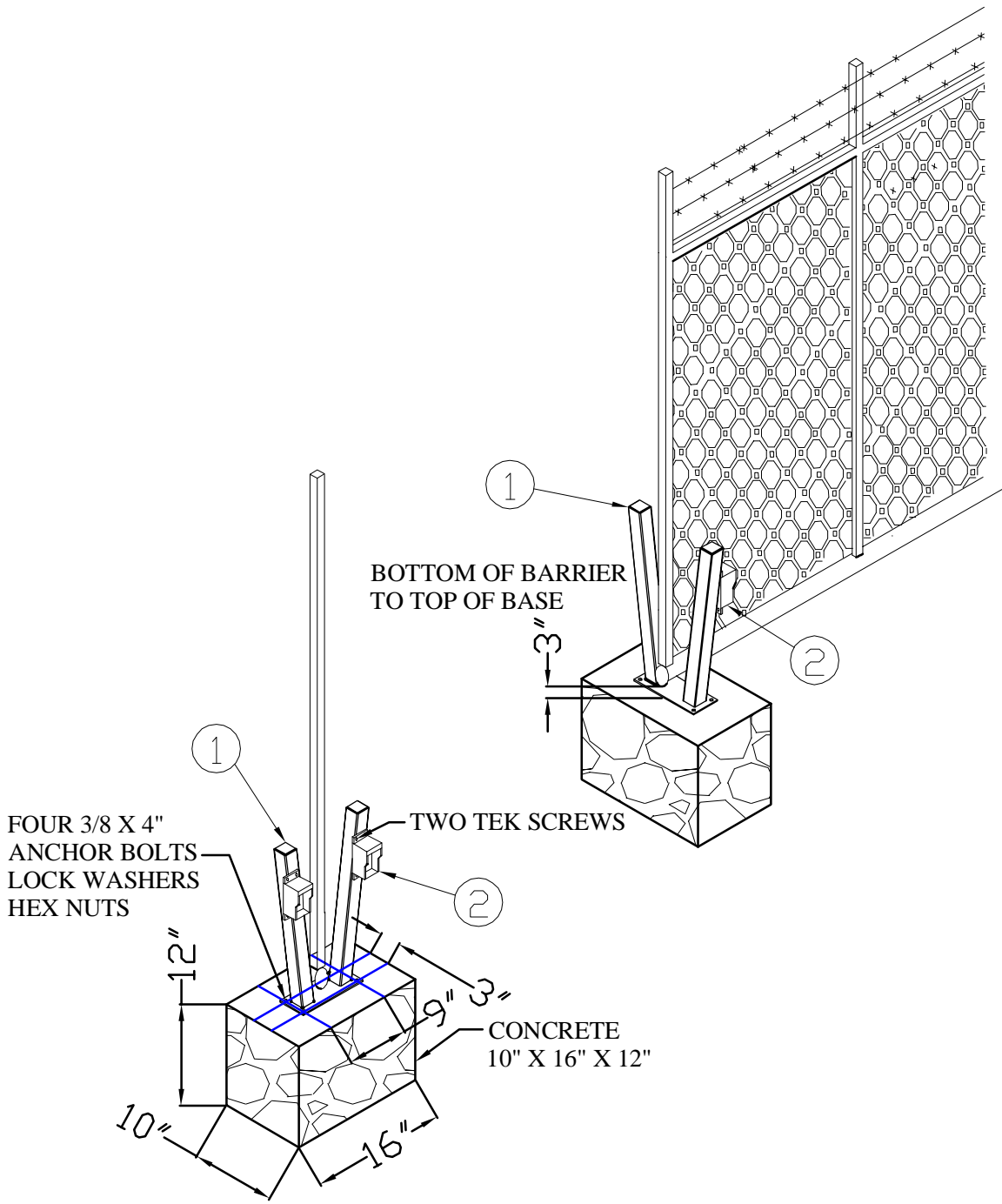

**SURFACE MOUNT STANCHION**

REF NO.	PART NO.	DESCRIPTION	REQ NO
1	FGO638	Surface Mount Stanchion Unit	1
2	PEO404	Photo Eye ( 2 on operator)	2
3	N/A	Tek Screw	4
4	N/A	3/8" x 4" Anchor Bolt	4
5	N/A	3/8" Lock Washer	4
6	N/A	3/8" Hex Nut	4
7	N/A	CONCRETE PAD 10" X 16" X 12"	4

# TILT-A-WAY DCM MAGLOCK ASSEMBLY

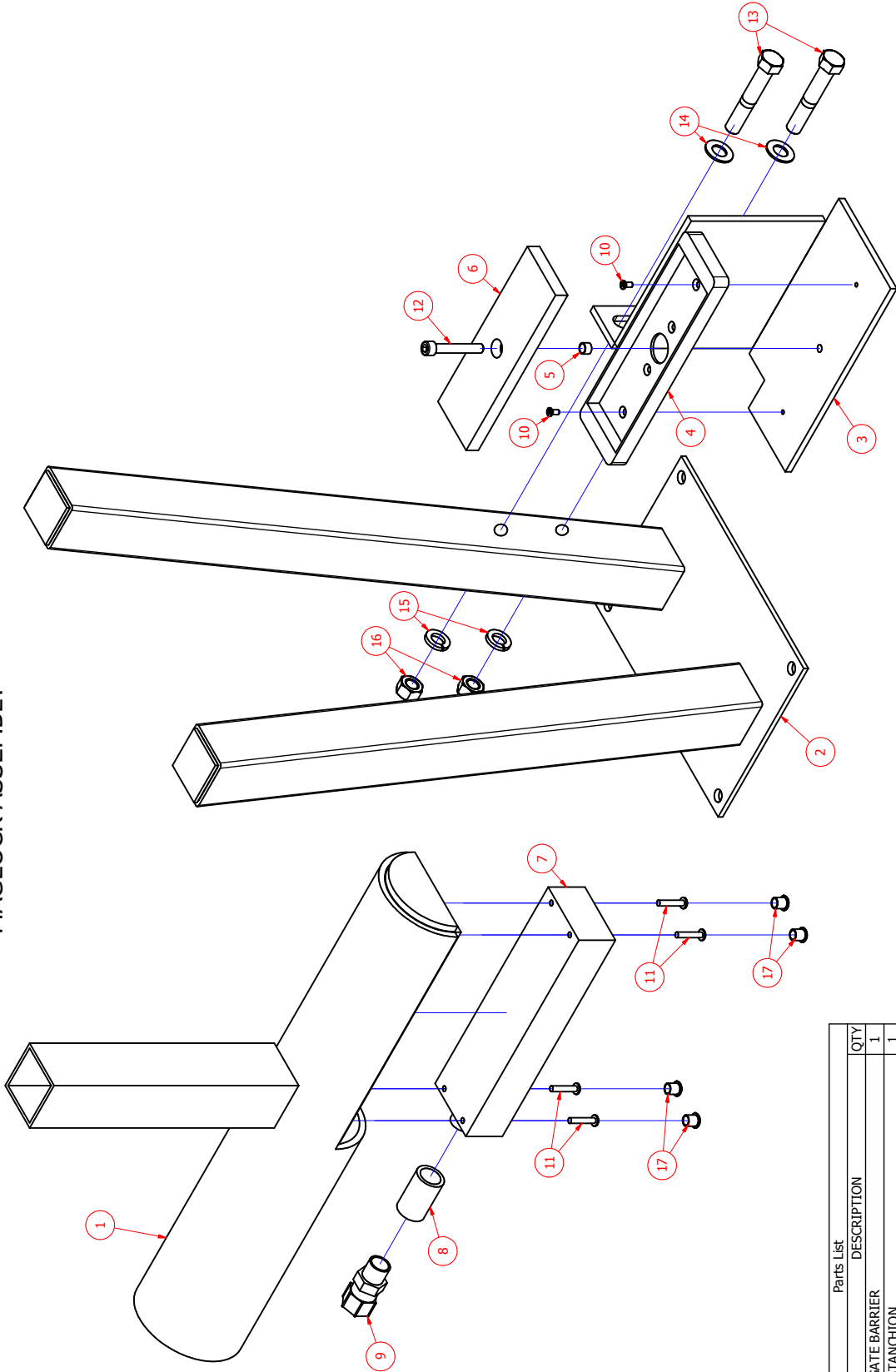

ITEM	PART NUMBER	DESCRIPTION	QTY
1	N/A	GATE BARRIER	1
2	FG0638	STANCHION	1
3	FG0419R	ARMATURE MOUNT RIGHT HAND (DYNALOCK)	1
	FG0419L	ARMATURE MOUNT LEFT HAND (DYNALOCK)	1
4	N/A	ANTI-SPIN BRACKET	1
5	N/A	ARMATURE SPACER	1
6	N/A	ARMATURE	1
7	N/A	MAGNET ASSEMBLY	1
8	PE0279-1	CONDUIT COUPLER	1
9	PE0279	1/2 STEEL STRIAN RELEASE	1
10	N/A	8-32 X 3/8 Countersunk Flat Head Screw	2
11	N/A	10-32 X 1" Machine Screw	4
12	N/A	5/16-18 x 2" Hexagon Socket Button Head Cap Screw	1
13	N/A	1/2-13 X 3" Hex Bolt	2
14	N/A	1/2 Flat Washer	2
15	N/A	1/2 Lock Washer	2
16	NA	1/2-13 Hex Nut	2
17	N/A	PLUG BUTTON	4

DRAWN T.Henry	10/31/2013	IDEAL MFG., INC.	2011 Harnish Blvd. Billings MT 59101	Rel. (406) 656-4360
CHECKED QA	3/24/2016	TITLE	DCM MAGLOCK ASSEMBLY	
MFG		SIZE	DCM-1015	REV
APPROVED		SCALE		
		DWG NO		
		SCALE		
				SHEET 1 OF 1

## Tilt-A-Way DCM Trouble Shooting Guide

When calling Ideal Mfg., Inc. for trouble shooting help please note which lights on all of the boards are on.

The following lights are normally on.

### Logic Board.

Light P1 (red power light).

Light CAN1 (green communication to Motor Board, red communication lost to Motor Board)

Light I3 (red stop circuit normally closed).

### Motor Board.

Light DS2 (green power light).

PROBLEM	DISPLAY	LIGHTS ON	SOLUTION
Gate closed and will not open	Blank	None	Power lost. Breaker turned off. Check battery connections and incoming ac power. Broken spring or cable safety switch open.
Gate closed and will not open	Full Closed	P1 CAN1	Stop circuit open. Check all external stop push buttons.
Gate closed and will not open	Full Closed	P1 CAN1 I3 I12	Opening safety edge active or shorted. Check for obstruction or replace if shorted.
Gate closed and will not open	Full Closed Schedule Lockout	P1 CAN1 I3	Lockout Schedule active, Turn lockout schedule off in menu.
Gate closed and will not open	Full Closed Low Voltage Secure	P1 CAN1 I3	Battery voltage is low. Check battery charge for proper operation and battery connections.
Gate closed and will not open	Full Closed Scheduled auto-open	P1 CAN1 I3	Check Lockout schedule for over lapping times with Auto-open schedule.
Gate closed and will not open	Full Closed Service Lockout	P1 CAN1 I3	Service lockout for all maintenance has been disabled. In menu Service change to Controller Enabled.
Gate opened and will not close	Blank	None	Power lost. Breaker turned off. Check battery connections and incoming ac power. Broken spring or cable safety switch open.
Gate opened and will not close	Full Open	P1 CAN1	Stop circuit open. Check all external stop push buttons.
Gate opened and will not close	Full Open	P1 CAN1 I3 I11	Closing safety edge active or shorted. Check for obstruction or replace if shorted.

## Trouble Shooting Guide

<b>PROBLEM</b>	<b>DISPLAY</b>	<b>LIGHTS ON</b>	<b>SOLUTION</b>
Gate opened and will not close	Full Open Pending Auto Close	P1 CAN1 I3 I5	Aux timer is active. Clear input to I5 Aux timer.
Gate opened and will not close	Full Open Pending Auto Close	P1 CAN1 I3 I6	Timer hold is active. Clear input to I6 Timer hold.
Gate opened and will not close	Full Open Pending Auto Close	P1 CAN1 I3 I7	Timer set is active. Clear input to I7 Timer set
Gate opened and will not close	Full Open Pending Auto Close	P1 CAN1 I3 I8	Reveres open loop is active. Clear input to I8 Reveres open loop.
Gate opened and will not close	Full Open Pending Auto Close	P1 CAN1 I3 I9	Aux # 1 input is active. Clear input to I9 Aux # 1 input.
Gate opened and will not close	Full Open Pending Auto Close	P1 CAN1 I3 I10	Aux # 2 input is active. Clear input to I10 Aux # 2 input.
Gate opened and will not close	Full Open Schedule Auto-Open	P1 CAN1 I3	Auto-Open Schedule active. Turn Auto-Open Schedule off in menu.
Gate opened and will not close	Full Open Low Voltage Failsafe	P1 CAN1 I3	Battery voltage is low. Check battery charge for proper operation and battery connections.
Gate in any position and will not move		CAN1	Fuse F1 5 amp blown on Logic Board. Replace with same type and rating.
Gate in any position and will not move	No Motor Current or Current Sensor Fail	P1 CAN1 I3 DS2	Fuse F2 20 amp slow blow on Motor Control Board blown. Replace with same type and rating. Check wires to motor for damage. Current Sensor on Motor Control Board has Failed. Replace Motor Control Board

## Trouble Shooting Guide

<b>PROBLEM</b>	<b>DISPLAY</b>	<b>LIGHTS ON</b>	<b>SOLUTION</b>
Gate stopped mid-travel	Stopped mid-travel Entrapment stop Obstruction detected UL reset to clear	P1 CAN1 (red) A1 (red) I3	UL Entrapment activated. Check for obstructions in operator and around barrier. Push red UL rest button. Check inherent settings.
Gate stops and reverses and stops during closing cycle	Stopped mid-travel	P1 CAN1 I3	Safety threshold closing set to low. Check gate balance and mechanical functions. Check motor current in Real-Time menu and adjust threshold closing in Timing and Options / Safety Responses.
Gate stops and reverses and stops during opening cycle	Stopped mid-travel	P1 CAN1 I3	Safety threshold opening set to low. Check gate balance and mechanical functions. Check motor current in Real-Time menu and adjust threshold opening in Timing and Options / Safety Responses.
Gate runs slow in both open and close cycle.	Bad Position Pot		Check potentiometer, turns with drive sprocket, loose or broken wire.
Gate will not function.	General System Error		Press and release ENT/MAIN button on display board. Make note of error message. Repeat until all errors are cleared. Gate should now function, so long as the problem isn't continuing to exist. Check CANBUS wiring on logic board, and motor control board.
Gate stopped mid travel	No Motor Current or Current Sensor Fail		Check Potentiometer wiring, (+5V and GND wires switched)

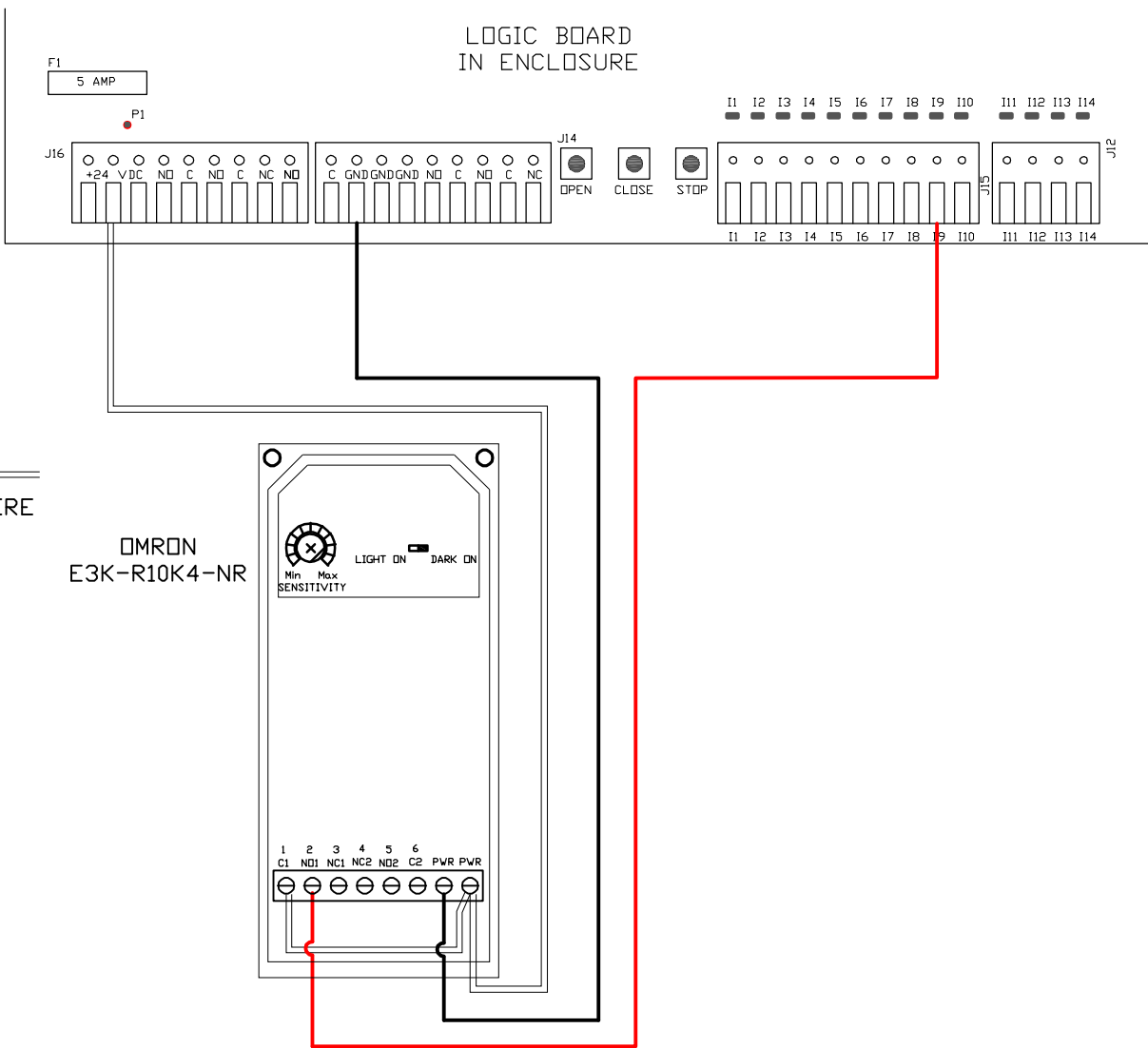

THE RECEIVER N/O CONTACT IS CONNECTED TO TERMINAL 19 ON THE LOGIC BOARD.  
 FOR THE PHOTO EYE TO ACT AS A SAFETY AUXILIARY #1 INPUT FUNCTION ASSIGNMENT WILL BE SET TO  
 "REVERSE OPEN LOOP"  
 PRESS AND HOLD BUTTON SW2 ON THE INTERFACE BOARD UNTIL DISPLAY CHANGES THEN RELEASE THE BUTTON  
 PRESS BUTTON SW4 AND RELEASE UNTIL THE DISPLAY SHOWS  
 "TIMING AND OPTIONS"  
 PRESS AND RELEASE BUTTON SW1 TO ENTER THE MENU THE DISPLAY WILL CHANGE TO  
 "TIMINGS AND OPTIONS"  
 "BASIC SETTINGS"  
 CONTINUE TO PRESS AND RELEASE BUTTON SW4 UNTIL THE DISPLAY SHOWS  
 "TIMINGS AND OPTIONS"  
 "AUXILIARY I / O"  
 PRESS AND RELEASE BUTTON SW1 TO ENTER THE SUBMENU THE DISPLAY WILL SHOW  
 "AUXILIARY # 1 INPUT FUNCTION ASSIGNMENT"  
 PRESS AND RELEASE BUTTON SW1 TO ENTER  
 PRESS AND RELEASE BUTTON SW4 UNTIL THE DISPLAY SHOWS  
 "REVERSE OPEN LOOP"  
 PRESS AND RELEASE BUTTON SW1 TO SAVE  
 PRESS AND RELEASE BUTTON SW2 UNTIL YOU EXIT ALL MENUS  
 THE GATE WILL STOP AND REVERSE WHEN CLOSING TO FULL OPEN AND SET THE AUTO CLOSE TIMER

**TILT-A-WAY DCM  
 REFLECTIVE TYPE PHOTO EYE**

REF NO.	PART NO.	DESCRIPTION	REQ NO
1	PEO434	Photo Eye 24-VDC	1



## INFORMATIONS IMPORTANTES SUR LA SÉCURITÉ

**Avant d'installer le programme d'installation doit lire et comprendre les instructions du manuel et de sécurité du propriétaire. Le propriétaire doit lire et conserver ce manuel du propriétaire. Lire et suivre toutes les instructions.**

### **AVERTISSEMENT-POUR RÉDUIRE LE RISQUE DE BLESSURES OU LA MORT AUX PERSONNES**

1. Ne pas faire fonctionner la porte à moins que tous les dispositifs de sécurité sont connectés et fonctionnent correctement.
2. Ne pas permettre aux enfants de jouer sur ou autour d'une porte. Gardez tous les contrôles hors de portée des enfants.
3. Portes automatiques ne sont pas destinés à un usage piéton. Les piétons doivent être fournis une entrée séparée distincte de la porte automatique.
4. Ne jamais faire fonctionner un système de porte automatique sans contact visuel afin qu'il puisse être arrêté si nécessaire.
5. Les contrôles d'accès, sont nécessaires, à monter au moins 6 pieds de la porte et l'opérateur.
6. Coupez l'alimentation avant d'effectuer toute opération de maintenance sur votre portail ou de l'opérateur.
7. Gardez votre porte bien entretenus-ont une personne qualifiée faire toutes les réparations.
8. Un technicien qualifié doit tester votre porte mensuelle. La porte DOIT remonter au contact avec un objet rigide ou d'arrêt quand un objet active un capteur sans contact. Après réglage de la force de la limite de Voyage, retester l'opérateur de porte. Ne pas ajuster et tester à nouveau l'opérateur de porte correctement peut augmenter le risque de blessure ou de décès.
9. La porte et l'opérateur doivent avoir deux dispositifs de sécurité appropriés pour correspondre à l'installation de la classe de porte.
10. Opérateur et la barrière doivent afficher des panneaux d'avertissement sur les deux côtés, en vue de l'opérateur.
11. Ne pas installer le poids supplémentaire à la barrière de la porte, votre barrière a été équilibré à l'usine, si vous ajoutez du poids à la porte barrière il fera de votre porte hors de l'équilibre, ce qui pourrait entraîner un dysfonctionnement.
12. Seul le personnel qualifié doit installer cet équipement. Le non-respect de cette exigence pourrait causer des blessures graves et ou la mort, pour lesquels le fabricant ne peut pas être tenu responsable.
13. Les dispositifs de sécurité, tels que les yeux de photo et les bords d'inversion doivent être installés pour assurer la protection personnelle la propriété et les piétons.
14. Avant la mise sous tension Assurez-vous que la tension correcte a été fournie au moteur électrique et l'équipement a été correctement mise à la terre.
15. Toujours garder les gens et les objets de la porte. PERSONNE NE DOIT TRAVERSER LE PARCOURS DE LA PORTE EN MOUVEMENT.

## CLASSE DE GATES VEHICULES

### Glossaire

#### **CLASS I-RÉSIDENTIEL OPÉRATEUR GATE VÉHICULAIRE (3.19)**

Un opérateur de porte de véhicule (ou système) destinés à être utilisés dans des garages ou des aires de stationnement associés à une résidence de un à quatre familles monoparentales.

#### **CLASSE II-COMMERCIAL / GENERAL accès véhiculaire PORTAIL (3.4)**

Un opérateur de véhicule de grille (ou système) destiné à être utilisé dans un emplacement commercial ou la construction tels que l'unité multi-logements collectifs (cinq ou plus unité familiale), hôtel, garages, magasins de détail, ou d'autres bâtiments accessibles par le service de la population en général .

#### **CLASSE III-INDUSTRIEL / LIMITED ACCESS VÉHICULAIRE PORTAIL (3.11)**

Un opérateur de porte de véhicule (ou système) destinés à être utilisés dans un emplacement industriel ou la construction comme une zone de l'usine ou le quai de chargement ou d'autres endroits non accessibles par ou destinés à desservir le grand public. **CLASS IV-RESTRICTED**

#### **ACCÈS VÉHICULAIRE OPÉRATEUR GATE (3.20)**

Un opérateur de véhicule de grille (ou système) destiné à être utilisé dans un emplacement industriel surveillé ou la construction, comme une zone de sécurité de l'aéroport ou autre lieux d'accès restreint pas l'entretien du grand public, dans lequel l'accès non autorisé est empêché par l'intermédiaire d'une surveillance par un personnel de sécurité.

### INSTRUCTIONS POUR MODE D'EMPLOI TILT-A-WAY MODÈLE DCM

**Remarque: Utilisez le déverrouillage d'urgence que lorsque la porte ne se déplace pas**

1. Eteignez toutes les alimentations électriques. Vérifiez l'intérieur de l'opérateur pour voir si tous les ressorts et les câbles sont en contact. voir page Si elles ont brisé 12 et 13.
2. Repérez l'épingle à cheveux sur le chariot, voir page 17. Retirer la goupille de cheveux, puis retirer l'axe de pivot.
3. Gate barrière peut maintenant être soulevée manuellement à partir à la fin de la porte.
4. Reverse procédure pour fonctionner porte normalement.

## PROTECTION CONTRE LE PIÉGEAGE

Porte catégorie d'opérateurs	
glissière horizontale, ascenseur vertical, et le pivot vertical	Swing et barrière verticale (bras)
types de protection de Entrapment (A)	types de protection de Entrapment (A)
A, B1, B2, ou D	A, B1, B2, C, ou D
Notez-Le même type de dispositif ne doit pas être utilisé pour les deux moyens de protection piégeage. L'utilisation d'un seul appareil à la fois le sens d'ouverture et de fermeture est conforme à l'exigence; cependant, un seul appareil ne soit pas nécessaire pour couvrir les deux directions. Une combinaison d'un type B1 pour une direction et un de type B2 pour l'autre sens est l'équivalent d'un dispositif dans le but de se conformer aux exigences des moyens de protection soit piégeage. (a) Entrapment protection types: Type A - Inhérente système de protection de la provocation policière. Voir 31.1.5. Tapez B1 capteur -Non-contact (capteur photoélectrique ou l'équivalent). Voir 31.1.6 - 31.1.9. Tapez capteur B2 -Contactez (dispositif de bord ou l'équivalent). Voir 31.1.7 et 31.1.11 - 31.01.13. Type C - la force intrinsèque de limitation, d'embrayage réglables intrinsèque ou inhérente dispositif de décharge de pression. Voir 31/01/15 et 31.2.1.2 (b). Tapez dispositif D -Actuating exigeant une pression continue à maintenir l'ouverture ou le mouvement de fermeture de la porte. Voir 31/01/16 et 31/01/17.	

## **Tilt-A-Way DCM**

### **INFORMATIONS GÉNÉRALES**

Tilt-A-Way DCM porte pivot vertical fonctionne sur deux batteries de 12 Vdc (piles non comprises). Nous recommandons deux entretien de l'acide sans plomb 12 volts série de cycle profond 27 batterie 85 ampères-heures ou équivalent. Les deux batteries de 12 volts sont câblés en série pour fournir 24 volts aux tableaux de commande. Le faisceau de câblage est équipé de bornes d'anneau destiné à se connecter à la batterie post type boulon (fil rouge à fil positif et noir au négatif). Voir le schéma de câblage à la page 9 de ce manuel. Ne pas inverser la polarité des piles à la carte de la batterie ou circuit. De graves dommages se produira. Débranchez la batterie et toutes les sources d'alimentation avant d'installer tous les périphériques. Ne pas effectuer le soudage alors que le câble moteur est branché sur la carte de commande ou de la batterie connectée. graves dommages à la carte de commande et la batterie se produira.

Attention - Risque d'explosion si la batterie est remplacée par un type incorrect.

Jetez les piles usagées conformément aux instructions.

Tilt-A-Way DCM porte pivot vertical a un tableau de commande programmable, ce qui permet de nombreuses fonctions programmables dans diverses combinaisons (voir la section de programmation à la fin de ce manuel). Le panneau de contrôle a des ajustements de détection de courant, qui peuvent être réglés au niveau désiré. Si la porte change de direction deux fois et arrête en raison de la détection de courant de la carte de contrôle devra être UL réinitialisé. Cet ajustement est réglé en usine, mais peut-être besoin de réglage. Rappelez-vous, si la porte change de direction lorsqu'il est actionné sans contact avec un obstacle, puis de minimiser la sensibilité (augmentation vigueur) peut être nécessaire. Ne pas augmenter plus que nécessaire.

Un chargeur de batterie est fourni pour garder les batteries chargées. Voir le manuel du chargeur propriétaire pour un bon fonctionnement.

Un technicien qualifié doit vérifier et régler les commandes de la force, la vitesse et la sensibilité mensuelle. Le solde de la barrière doit également être vérifié et ajusté mensuellement par un technicien qualifié.

**TILT-A-WAY DCM  
OPÉRATEUR AJUSTEMENT DU SYSTÈME DE BALANCE  
DESSIN # DCM-1003**

**Porte de route TILT-A-WAY doit être équilibrée pour offrir le moins de résistance contre le mouvement à la fois des positions extrêmes ou combinaison des deux haut et en bas.**

**Réglage de la balance est réalisé par la tension du câble, la position de la poulie de câble ou d'une combinaison des deux.**

**Un ou deux systèmes de câbles sont intégrés et tout ajustement préformés d'un côté doivent être dupliqués sur le côté opposé, si deux systèmes de câbles sont utilisés.**

**Procédure d'instruction pour le remplacement des câbles, ou les ressorts sont à la page 30.**

**AVERTISSEMENTS-TRÈS IMPORTANT DE SÉCURITÉ**

- 1. Avant d'effectuer tout entretien ou de réglage, mettre l'interrupteur d'alimentation hors tension situé à l'intérieur de l'enceinte du panneau de commande, et débrancher la batterie. Avant d'effectuer tout réglage, retirer la broche de liaison de transport (voir page 19)**
- 2. Tout ajustement préformé sur le câble réa doit être précédée par la libération de toutes les tensions de câble au niveau des connexions à ressort.**

**CONDITIONS ET SOLUTIONS**

- 1. Condition: Porte lourde à la fois haut et en bas des positions.  
Solution: Augmente la tension du câble.**
- 2. Condition: la lumière porte à la fois haut et en bas des positions.  
Solution: Diminuer la tension du cable.**
- 3. Condition: Porte lourde en position vers le bas seulement.  
Solution: Lower réa de câble et la tension du câble d'augmentation.**
- 4. Condition: la lumière porte à la position vers le bas seulement.  
Solution: Raise câble réa et de diminuer la tension du câble.**
- 5. Condition: Porte lourde en position haute seulement.  
Solution: Raise câble réa et de diminuer la tension du câble.**
- 6. Condition: la lumière porte jusqu'à la position seulement.  
Solution: la tension du câble d'augmentation câble réa inférieur.**
- 7. Condition: Porte lourde à des positions intermédiaires.  
Solution: Déplacer le câble réa avant.**
- 8. Condition: la lumière porte à des positions intermédiaires.  
Solution: Déplacer câble réa vers l'arrière.**

## Tilt-A-Way DCM

24 volts menu du programme de moteur à engrenages à courant continu  
23/03/2016

Pour accéder au menu principal, appuyez et maintenez le bouton SW2 pendant environ 4 secondes.

Pour accéder au menu principal, appuyez et maintenez le bouton SW2 pendant environ 4 secondes.

Pour entrer dans le menu ou sous-menu presser et relâcher le bouton SW1.

Pour enregistrer les modifications des sous-menus appuyez sur, puis relâchez la touche SW1.

Pour quitter les sous-menus, ou le menu principal, appuyez sur et relâchez le bouton SW2.

ÉTEMPS RÉEL ÉTAT. Ce menu est utile pour résoudre les problèmes avec le système de grille.

- Statut d'entrée. Ce sous-menu vous pouvez afficher les entrées sont actives, ou inactif.

bouton d'ouverture de l'état d'entrée "Input clair / Input affirmé"

Etat d'entrée bouton de fermeture "Input clair / Input affirmé"

bouton d'arrêt d'état d'entrée "Input clair / Input affirmé"

Etat d'entrée unique bouton "Input clair / Input affirmé"

Etat d'entrée inverse ouvert, borne "Input clear / Input a affirmé"

Entrée état timer set "Input clair / entrée affirmé"

Entrée état temps de maintien "Input clair / Input affirmé"

Etat d'entrée aux minuterie "Entrée Taquet / Entrée affirmé"

Etat d'entrée UL reset (à bord) "Input clair / Input affirmé"

Etat d'entrée à distance (n.ö. de contact) "Contact ouvert / Contact fermé"

Etat d'entrée à distance (N.C. de contact) "Contact ouvert / Contact fermé"

fente de la boucle d'état d'entrée # J3 "Input clair / Input affirmé"

fente de la boucle d'état d'entrée # J5 "Input clair / Input affirmé"

fente de la boucle d'état d'entrée # J7 "Input clair / Input affirmé"

Etat d'entrée auxiliaire # 1 "Entrée claire / Entrée affirmé"

Etat d'entrée auxiliaire # 2 "Entrée claire / Entrée affirmé"

Etat d'entrée feuille # 1 fermer obstrue bord "Input clair / Input affirmé"

Etat d'entrée feuille # 1 bord obstruent ouvert "Input clair / Input affirmé"

Etat d'entrée feuille # 1 limite de fermeture "Input clair / Input affirmé"

Etat d'entrée feuille # 1 limite d'ouverture "Input clair / Input affirmé"

Etat d'entrée feuille # 2 à proximité obstrue bord "Input clair / Input affirmé"

Etat d'entrée feuille # 2 bord obstruent ouvert "Input clair / Input affirmé"

Etat d'entrée feuille # 2 limite de fermeture "Input clair / Input affirmé"

Etat d'entrée feuille # 2 limite d'ouverture "Input clair / Input affirmé"

Etat de sortie. Dans ce sous-menu, vous pouvez voir les relais de sortie de sorcière sont verrouillés ou déverrouillés.

Etat de sortie piègeage (K1) "relais non activé / relais excité"

Etat de la sortie pré-alarme (K2) "relais non activé / relais excité"

Etat de la sortie auxiliaire # 1 (K3) "relais non alimenté / relais excité"  
Etat de la sortie auxiliaire # 2 (K4) "relais non alimenté / relais excité"  
Etat de la sortie auxiliaire # 3 (K5) "relais non alimenté / relais excité"

Courant moteur. (Pour le modèle DCM uniquement) Ce sous-menu est utilisé pour afficher ampérage du moteur de sorte que la valeur appropriée peut être insérée dans le seuil de sécurité sous-menu.

Feuille # 1 seuil d'écart maximal, dernier cycle (porte arrêté)  
X.X A (porte arrêté)

Feuille Courant moteur # 1 (portail mobile)  
Approx Courant moteur (portail mobile)

x.x (changements de cette valeur que la porte se déplace à travers un cycle. Suivre la plus forte valeur au cours du cycle pour entrer dans un bon réglage du seuil de sécurité sous-menu feuille # 1) A

Feuille # 2 seuil d'écart maximal, dernier cycle (porte arrêté)  
X.X A (porte arrêté)

Feuille Courant moteur # 1 (portail mobile)  
Approx Courant moteur (portail mobile)

x.x (changements de cette valeur que la porte se déplace à travers un cycle. Suivre la plus forte valeur au cours du cycle pour entrer dans un bon réglage du seuil de sécurité sous-menu feuille # 2) A

Voltage de batterie. (Pour le modèle DCM uniquement) Ce sous-menu affiche la tension étant fournie à la carte logique. Toute tension sur 24 Vcc montrera que 24 volts.

Feuille # 1 / 24.0 volts

Feuille # 2 / 24.0 volts

- TIMING ET OPTIONS. Dans ce menu, vous pouvez régler les paramètres de l'utilisateur.

Réglages de base

Heure de l'horloge actuelle (réglée en usine en temps de montagne) "12:01 am"

Date actuelle du calendrier "01/01/2013"

Auto-Close retard (réglé en usine à 10 secondes) "OFF / 15:00"

Fermer commande sur manèges fermeture automatique (réglage d'usine Enabled) "Activé / Désactivé"

entrée unique règle la minuterie fermeture automatique (réglage d'usine Enabled) "Activé / Désactivé"

entrée unique sens inverse (réglage d'usine Enabled) "Activé / Désactivé"

Pause délai avant inversion de sens (réglage d'usine Enabled) "Activé / Désactivé"

Réponses de sécurité

Le fonctionnement du moteur maximum (0:30 secondes réglée en usine) "midi 05-01:30"

Inversion de mouvement sur la sécurité (réglé en usine Enabled) "Activé / Désactivé"

Sécurité règle la minuterie (réglage d'usine Enabled) de fermeture automatique "Désactivé / Activé"

La sécurité intrinsèque (pour le modèle DCM uniquement réglé en usine Enabled) "Activé / Désactivé"

Seuil de sécurité Feuille # 1 fermeture (pour le modèle DCM seule valeur fixée à l'usine, la sécurité intrinsèque doit être vérifiée par mois) "0.0 A à 20.0 A"

Seuil de sécurité Feuille # 1 ouverture (pour le modèle DCM seule valeur fixée à l'usine, la sécurité intrinsèque doit être vérifiée par mois) "0.0 A à 20.0 A"

Seuil de sécurité Feuille # 2 fermeture (pour le modèle DCM seule valeur fixée à l'usine, la sécurité intrinsèque doit être vérifiée par mois) "0.0 A à 20.0 A"

Seuil de sécurité Feuille # 2 ouverture (pour le modèle DCM seule valeur fixée à l'usine, la sécurité intrinsèque doit être vérifiée par mois) "0.0 A à 20.0 A"

Appel du moteur ignorer période (réglé en usine 1.0 secondes) "0.0 secondes à 2.0 secondes"

Position Feedback Obstruction Detect (pour portail hydraulique uniquement) (réglé en usine Désactivé) "Désactivé / Activé"

Surveillé Obstruction Edge "Activé / Désactivé"

Réglage de la vitesse (pour le modèle DCM uniquement)

Position de la porte pour la rampe jusqu'à la fin (réglé en usine 5%) "XX%"

Position de la porte pour rampe descendante démarrage (réglé en usine 80%) "XX%"

Arrêt lente descente de la rampe sur la porte inversion (réglé en usine 0.5 secondes) "0.0 secondes à 3.0 secondes"

Vitesse rampe du moteur de départ (réglé en usine 60%) "XX%"

La vitesse maximale du moteur (réglé en usine à 100%) "XX%"

La vitesse finale de la rampe du moteur (réglé en usine 40%) "XX%"

Fermeture annexe. Lorsque le calendrier de verrouillage est réglé la porte ne sera pas ouvert jusqu'à ce que le calendrier de lock-out se termine, sauf pour une boucle libre de sortie va ouvrir la porte, ou une entrée de borne d'horloge d'entrée, I7.

Entrée verrouillage permet annexe # 1 "Activé / Désactivé"

Horaire de début de verrouillage d'entrée # 1 "fixé pour le temps de commencer à lockout am ou pm et jour de la semaine"

Entrée fin de lock-out annexe n ° 1 "fixé pour le temps de mettre fin à un lock-out am ou pm et jour de la semaine"

Répétez l'opération pour tous les jours que le verrouillage est nécessaire.

Auto-Ouvrir le calendrier. Lorsque le calendrier d'ouverture automatique est réglé aucune fonction fermera la porte jusqu'à ce que le calendrier d'ouverture automatique se termine.

Porte à ouverture automatique permettent annexe # 1 "Activé / Désactivé"

Auto-Open Gate heure de début Annexe # 1 "fixé pour le temps de commencer h auto-ouvert ou h et jour de la semaine"

Auto-porte ouverte fin Horaire du temps # 1 "fixé pour temps de mettre fin h auto-ouvert ou h et jour de la semaine"

Répétez l'opération pour tous les jours à ouverture automatique est nécessaire.

- Batterie (pour le modèle DCM uniquement)
  - Fail-Safe / Fail-sécurisé sélection "sécurité positive / échec sécurisé"
  - Tension de la batterie de décrochage (réglé en usine de 18.0 volts) "17.0 à 23.0"
  - Tension de rétablissement de la batterie (réglé en usine 20.0 volts) "18.0 à 23.0"
- Auxiliaire I / O
  - Auxiliaire # 1 entrée affectation de la fonction "non utilisé / open / close / stop / cale unique / minuterie / marche arrière en boucle ouverte / ouverture bord de sécurité / bord de sécurité de fermeture / UL piégeage remise à zéro"
  - Auxiliaire # 2 entrée affectation de la fonction "non utilisé / open / close / stop / cale unique / minuterie / marche arrière en boucle ouverte / ouverture bord de sécurité / bord de sécurité de fermeture / UL piégeage remise à zéro"
  - Sortie auxiliaire # 1 fonction "sortie désactivée / secondaire piégeage alarme / maintien aux relais lorsque la maintenance due / hold aux relais fermeture automatique impulsion de retard / déverrouillage / impulsion aux relais fermer l'interrupteur de fin de course / impulsion aux relais limite d'ouverture commutateur / impulsion aux relais ouverts mouvement / impulsion aux relais à proximité mouvement / tenir aux relais fermer l'interrupteur de fin de course / tenir aux relais de fin de course d'ouverture / tenir aux relais mouvement d'ouverture / hold aux relais mouvement de fermeture / impulsion aux relais sur motion pré-alarme / impulsion aux relais sur l'ouverture pré-alarme seulement / impulsion aux relais fermeture Pré alarme seulement / impulsion aux relais entrée auxiliaire # 1 / hold aux relais entrée auxiliaire # 1 / impulsion aux relais entrée auxiliaire # 2 / hold aux relais entrée auxiliaire # 2 / hold aux relais sur une motion / hold aux relais sur la boucle d'armement assertion "
  - Sortie auxiliaire # 1 durée d'impulsion "0.1 secondes à 5.0 secondes"
  - Sortie auxiliaire fonction # 2 "sortie désactivée / secondaire piégeage alarme / maintien aux relais lorsque la maintenance due / hold aux relais fermeture automatique impulsion de retard / déverrouillage / impulsion aux relais fermer l'interrupteur de fin de course / impulsion aux relais limite d'ouverture commutateur / impulsion aux relais ouverts mouvement / impulsion aux relais à proximité mouvement / tenir aux relais fermer l'interrupteur de fin de course / tenir aux relais de fin de course d'ouverture / tenir aux relais mouvement d'ouverture / hold aux relais mouvement de fermeture / impulsion aux relais sur motion pré-alarme / impulsion aux relais sur l'ouverture pré-alarme seulement / impulsion aux relais fermeture Pré alarme seulement / impulsion aux relais entrée auxiliaire # 1 / hold aux relais entrée auxiliaire # 1 / impulsion aux relais entrée

auxiliaire # 2 / hold aux relais entrée auxiliaire # 2 / hold aux relais sur une motion / hold aux relais sur la boucle d'armement assertion "

Sortie auxiliaire # 2 durée d'impulsion "0.1 secondes à 5.0 secondes"

Sortie auxiliaire fonction # 3 "sortie désactivée / secondaire piégeage alarme / maintien aux relais lorsque la maintenance due / hold aux relais fermeture automatique impulsion de retard / déverrouillage / impulsion aux relais fermer l'interrupteur de fin de course / impulsion aux relais limite d'ouverture commutateur / impulsion aux relais ouverts mouvement / impulsion aux relais à proximité mouvement / tenir aux relais fermer l'interrupteur de fin de course / tenir aux relais de fin de course d'ouverture / tenir aux relais mouvement d'ouverture / hold aux relais mouvement de fermeture / impulsion aux relais sur motion pré-alarme / impulsion aux relais sur l'ouverture pré-alarme seulement / impulsion aux relais fermeture Pré alarme seulement / impulsion aux relais entrée auxiliaire # 1 / hold aux relais entrée auxiliaire # 1 / impulsion aux relais entrée auxiliaire # 2 / hold aux relais entrée auxiliaire # 2 / hold aux relais sur une motion / hold aux relais sur la boucle d'armement assertion "

Sortie auxiliaire # 3 durée d'impulsion "0.1 secondes à 5.0 secondes"

○ Boucle et cession à distance

Affectation de fonctionnalité Loop, slot J3 "slot de boucle désactivé boucle / sécurité / sans boucle de sortie / boucle d'ombre / armement boucle"

affectation de fonctionnalité Loop, slot J5 "slot de boucle désactivé boucle / sécurité / sans boucle de sortie / boucle d'ombre / armement boucle"

affectation de fonctionnalité Loop, slot J7 "slot de boucle désactivé boucle / sécurité / sans boucle de sortie / boucle d'ombre / armement boucle"

Télécommande affectation des boutons "à distance ne sont pas utilisés open-seule commande / commande / single"

○ Porte physique

SetupNumber de grille leafs installé "1/2" 1 est la porte simple, 2 est maître esclave

Type de moteur (DC doit être orientée) "DC orientée / DC entraînement direct pompe hydraulique / AC"

Position feed-back capteur installé (réglage d'usine Enabled) "Désactivé / Activé"

Droite de sélection gauche-main "/ gauche à droite" Ceci permet de sélectionner ce qui porte commence d'abord dans un système maître-esclave.

Feuille stagger delay "0.0 secondes à 15.0 secondes"

○ Un service

Lockout Service

Définir un lock-out de service pour tout l'entretien "contrôleur activé / désactivé du contrôleur (portail ne bouge pas)"



- Rappels d'entretien
  - entretien de rappel de service non nécessaire / Maintenance nécessaire
  - Réinitialiser le cycle de service compteur à zéro "non / oui"
  - Définir rappel de service sur compteur de cycle "off / xxx (réglé en usine à 2500"
  - Définir rappel de service ou après la date "Activé / Désactivé"
  - Si le service de rappel ou après la date est activée, la date peut être réglée ici "21/08/2021"
- Relais de testrelais de test
  - Test de relais / Latch "Les relais ne verrouillées / verrouillage le relais K1 / verrouillage relais K2 / K3 Relais à verrou / Relais à verrou K4 / K5 Relais à verrou"
- Config usine. Ce sous-menu est pour une utilisation en usine.
  - Attention! Appliquer volts et couper étalonnage "24.0 volts"
  - Attention! Zéro vie compteur de temps de cycle "non / oui"
  - Attention! Réinitialiser tous les réglages par défaut "non / oui"Statistics
- Porte Cycle Count
  - Nombre de cycles total de la durée de vie de grille (000000)
  - Count o Cycle depuis la réinitialisation dernière de service (00000)
- Moteur bord # 1 bus. Ce sous-menu est une utilisation en usine.
- Moteur conseil # 2 bus. Ce sous-menu est une utilisation en usine.
- Des journaux d'événements
  - General Event Log
    - Event # 1 (le plus récent)
  - Sécurité Event Log
    - Event # 1 (le plus récent)

## Détecteur de boucle de véhicule



CE

# Mode d'emploi

---

## PRÉCAUTIONS ET AVERTISSEMENTS

---



*CEXIGENCES de la CE: Utiliser boucles pré-formé EMX avec suppression des surtensions intégrée pour conformité CE. À la terre, raccorder le blindage du câble en fil.*

*EXIGENCES de la CE: Utilisez CE coté alimentation pour conformité CE fournissant la répression comme spécifié par EN61000-4-5.*

*Ne doit pas être utilisé dans des applications de sécurité*

*Lorsque plus d'un détecteur de boucle est utilisé, valeur chacun d'eux à une fréquence différente.*

*Référez-vous au diagramme de DIP-switch pour les paramètres de fréquence.*

### IMPORTANT :

Ce produit est un accessoire ou une partie d'un système. Toujours lire et suivre les instructions du fabricant de l'équipement avant de connecter ce produit. Se conformer aux codes et normes de sécurité. Faute de quoi peut entraîner des dommages, blessures ou la mort.

---

## PRÉSENTATION DU PRODUIT

---

Détecteur de boucle ULT-PLG le véhicule est compatible avec la plupart des opérateurs de porte. L'ULT-PLG peut être utilisé dans le centre, en sécurité et sortie bouclent postes. Fonction d'affichage du The UltraMETER™, installation facile en affichant le réglage optimal requis pour détecter un véhicule étant placé sur la boucle. Dix réglages de sensibilité permettent un réglage fin du niveau de détection. Le fonctionnalité détecter sur Stop (DOS®) permet de détecter uniquement lorsqu'un véhicule est venu à un arrêt complet. Sortie B interrupteur permet la configuration de la sortie 2 pour FAIL, PULSE ON entrée, sortie ON PULSE ou même AS OUPUT A. Quatre réglages de fréquence une flexibilité dans la prévention de diaphonie dans les boucles multiples applications.

L'ULT-PLG est compatible avec une grande variété d'opérateurs de porte notamment :

- Advanced Access automatisation/FAAC CSL2000, CSW2000, RSW1000
- All-O-Matic SL100-DC
- Apollon 4300, 4500
- Chamberlain/Elite SL3000, CSW200
- IntelliGate systèmes IQ500, IQ5000
- Linéaire (OSCO) avec le contrôleur de l'APeX
- PowerMaster opérateurs avec les contrôleurs PowerMaster
- Les systèmes hilaires rotatif modèles SL1000C, SL1000I, SL1000R
- SECOM tard modèle opérateurs avec 10 connecteurs Molex
- TYM TyMetal 1000, TYM 2000
- Accès Viking modèles L-3, F-1, T-21, H-10, B-12, Q-4

## Spécifications

Sensibilité	10 niveaux, 0-9
UltraMETER™ Affichage	Indique le niveau de sensibilité optimale, 0-9 Aide au diagnostic
Boucle fréquence	4 réglages (low, med-low, med-Salut, élevé)
Boucle inductance	20... 2000µH (facteur Q > 5)
Boucle de mise à la terre	Transformateur d'isolation permet un fonctionnement avec des boucles de mauvaise qualité
Syntonisation automatique	Détecteur de tunes à boucle sur la mise sous tension et en suivant la fonction count de fréquence
Suivi environnemental	Compensation automatique
Protection contre les surtensions	Boucle des circuits protégés par des supresseurs de surtension
Détecter la sortie	État solide
Sortie B	État solide
B sortie inversée	État solide
Alimentation / boucle voyant de défaillance	LED verte
Détecter / fréquence count indicateur	LED rouge
ASB (sensibilité automatique Boost)	Augmente la sensibilité après la détection initiale afin d'éviter l'abandon en raison de la haute-lit véhicules
Puissance	12VDC... 24VDC (voir mises en garde et avertissements)
D'exploitation courant	15 mA
Température de fonctionnement	-40 ° C... 82°C (-40°F... 180°F) 0... 95 % d'humidité relative
Dimensions (L x l x H)	3.0"(76mm) x 0.9"(22mm) x 2.75"(70mm)
Poids	0.15 lbs. (68 g)
Connecteur	10 broches femelle



---

# OPÉRATION

---

## Mise sous tension

À mettre sous tension l'initialise de détecteur en ajustant automatiquement à la boucle. La LED verte indique que le détecteur est alimenté et opérationnel.

## Réglage de la fréquence

La fréquence de fonctionnement de la boucle est fonction de l'inductance de boucle spécifique et les réglages du commutateur DIP 1 et 2. L'objectif principal de la réglage de la fréquence est de permettre à l'installateur la possibilité de définir différentes fréquences pour les installations de boucles multiples, recommandée pour éviter diaphonie/interférence des noeuds adjacents. Après avoir changé le réglage de la fréquence, appuyez sur l'interrupteur de comptage de la fréquence de ré-initialiser le détecteur. Pour vérifier la fréquence de fonctionnement d'une boucle reportez-vous à la section de fréquence de comptage. Pour déterminer si la diaphonie entre les boucles adjacentes se produit, reportez-vous à la section Affichage de sensibilité UltraMETER.

## Affichage de sensibilité UltraMETER™

Affichage de sensibilité the UltraMETER™ simplifie le processus d'installation en affichant le réglage de la sensibilité nécessaire pour détecter un véhicule sur la boucle. Pour utiliser cette fonctionnalité, observer l'écran alors qu'un véhicule se déplace en position sur la boucle, notez le numéro affiché, puis ajuster le réglage de sensibilité (commutateur rotatif) à la position affichée.

En fonctionnement normal, lorsqu'un véhicule n'est pas sur la boucle, l'affichage est vierge. Les effets de diaphonie ou d'autres interférences peuvent être observés sur l'écran lorsque la boucle est vacante. Interférence ou diaphonie provoquera l'affichage pour indiquer un niveau, généralement de 8 ou 9. Il peut être nécessaire d'observer l'écran pendant une minute ou deux pour voir à cet effet. Changez la fréquence pour éviter la diaphonie.

## Réglage de la sensibilité ity setting

L'interrupteur rotatif 10 broches permet un réglage précis du niveau de détection. Le niveau de sensibilité augmente de la position 9 à 0 à la position 0 étant la sensibilité la plus faible. Les applications typiques nécessitent un réglage de 3 ou 4. The UltraMETER™ affichage de sensibilité simplifie le processus d'installation en affichant le réglage de la sensibilité nécessaire pour détecter un véhicule sur la boucle. Pour utiliser cette fonctionnalité, observer l'écran alors qu'un véhicule se déplace en position sur la boucle, notez le numéro affiché, puis ajuster le réglage de sensibilité (commutateur rotatif) à la position affichée.

## Compte de fréquence / Reset

Appuyez sur le commutateur de fréquence comte et compter le nombre de clignotements de la LED rouge. Chaque flash représente 10kHz. Pour aider à prévenir les interférences lorsque plusieurs détecteurs sont utilisés pour les lignes adjacentes, effectuer un comptage de la fréquence sur chaque détecteur pour confirmer que les fréquences de fonctionnement sont différents. Après un cycle de compte de fréquence, le détecteur réinitialise

## Boost de sensibilité automatique

Le Boost de sensibilité automatique provoque la sensibilité d'augmenter après la détection initiale. Cette fonctionnalité est utile pour prévenir l'abandon lors de la détection de véhicules haute-lit. La sensibilité revient à son niveau normal après que le véhicule quitte la boucle. Point décimal sur l'afficheur indique l'ASB sur.

## Sortie de présence output

Les paramètres de présence fournit deux sélections, la sortie peut être réglée pour présence infinie ou présence normale. Causes de présence infinies la sortie de rester en mode tant que le véhicule demeure sur la boucle de détection. Normal présence provoque la sortie pour remettre à zéro après 5 minutes. N'utilisez pas le paramètre de présence normale à moins que l'ouverture est protégée par un dispositif de sécurité secondaire tels que la CISR-4 X.

## Détecter-stop (DOS™)

Le detect-stop affecte B/b (inversé B sortie). Cette fonction exige qu'un véhicule fait un arrêt complet sur la boucle pour la sortie à activer. Cette fonctionnalité est utile dans les cas où le trafic transversal provoque la détection. detect-on-stop affects B and /B (inverted B output). This function requires that a vehicle come to a complete stop on the loop for the output to activate. This feature is useful in cases where cross-traffic causes the detection.

## Sortie B

Paramètres de sortie B permettent des impulsions sur l'entrée, des impulsions à la sortie, sortie B même comme présence et faute de boucle.

## Fail Safe / pas sûr

Causes de définir l'ULT-PLG pour activer la sortie de la présence à l'événement ne parviennent pas un échec de la boucle. Fail sûr paramètre provoque l'ULT-PLG ne pas à activer la sortie de la présence dans le cas où une défaillance de la boucle

## Controls and Indicators

### BOOST DE SENSIBILITÉ AUTOMATIQUE

	DIP Position de l'interrupteur 8
ASB a permis	sur
ASB hors	hors

### PRÉSENCE

	DIP Position de l'interrupteur 7
NORMAL	sur
INFINI	hors

### DÉTECTER-MARCHE-ARRÊT (DOS)

	DIP Position de l'interrupteur 6
DOS sur	sur
DOS horsoff	hors

### SORTIE B

MODE	Position de l'interrupteur DIP	
	4	5
Impulsion sur l'entrée	sur	sur
Impulsion sur la sortie (1)	hors	sur
B même que A	sur	hors
Boucle Faute	hors	hors

(1) Not used when DOS is selected

(1) n'est pas utilisé lorsque le DOS est sélectionné

### FAIL SAFE / SÉCURISÉ

	DIP Position de l'interrupteur 3
Sûr en cas d'échec	sur
Fail Safe	hors

### PARAMÈTRES DE FRÉQUENCE

FRÉQUENCE	DIP Position de l'interrupteur	
	2	1
Faible	sur	sur
Moyenne basse	sur	hors
Moyenne élevée	hors	sur
Haute	hors	hors

### RÉGLAGE DE LA SENSIBILITÉ

Sensibilité	Position 0.....9
	Faible... haut

### D DÉTECTER / FRÉQUENCE COUNT

	Red LED
Présence détectée	sur
Aucune présence	hors
Compte de fréquence	clignotant

### ULTRAMETER™ AFFICHAGE

Indique le réglage de la sensibilité nécessaire pour la détection de véhicule

### COMTE DE FRÉQUENCE / RESET

Appuyez sur pour commencer le nombre de fréquences, ré-Initialise après dépouillement



## Connexions

Broche du connecteur	Description
1	Boucle
2	Boucle
3	Power + (12VDC... 24VDC)
4	Pas de connexion
5	Pas de connexion
6	Sortie B
7	B sortie inversée
8	Sortie de présence
9	Power + (12VDC... 24VDC)
10	Commune

## Dépannage

Symptôme	Cause possible	Solution
LED verte clignote	Fil en boucle ouverte ou court-circuit	Vérifier la résistance de la boucle sur les broches boucle approprié sur le connecteur de carte de contrôle, .5 va de 5 $\omega$ .
LED verte clignote, 2 rapide	Boucle a été précédemment mises en court-circuit ou ouvrir	Vérifier la résistance de la boucle sur la boucle des broches sur le connecteur de la carte de contrôle.
Restes de détecteur à détecter après que véhicule a quitté la boucle	<ol style="list-style-type: none"><li>1. Défectueux en boucle</li><li>2. Mal sertis terminaux</li><li>3. Connexions desserrées</li></ol>	<ol style="list-style-type: none"><li>1. Tester megger de fil de la boucle à la terre, doit être &gt; 100 mégohms</li><li>2. Vérifier les connexions de boucle aux bornes</li><li>3. Les épissures de cocher sont correctement soudés et étanche à l'humidité</li><li>4. Affichage ULTRAMETER observer, niveau indiqué sur l'affichage indique décalage de fréquence résiduelle de boucle vacant à la présence de véhicule, appuyez sur le commutateur de fréquence nombre de ré-initialiser le détecteur</li></ol>
Détection intermittente	<ol style="list-style-type: none"><li>1. Défectueux en boucle</li><li>2. Mal sertis terminaux</li><li>3. Connexions desserrées</li><li>4. Diaphonie entre les boucles adjacentes</li></ol>	<ol style="list-style-type: none"><li>1. Tester megger de fil de la boucle à la terre, doit être &gt; 100 mégohms</li><li>2. Vérifier les connexions de boucle aux bornes</li><li>3. Les épissures de cocher sont correctement soudés et étanche à l'humidité</li><li>4. Définir les boucles adjacentes à des fréquences différentes (voir Réglage de la fréquence)</li></ol>
Pas de détection	<ol style="list-style-type: none"><li>1. Boucle en court-circuit ou ouvrir</li><li>2. Boucle sensibilité réglé trop basses</li></ol>	<ol style="list-style-type: none"><li>1. Résistance de boucle de cocher sur la ligne appropriée broches sur le connecteur de carte de contrôle, .5 va de 5 <math>\omega</math>.</li><li>2. Avec véhicule sur boucle, observer ULTRAMETER afficher, réglage de sensibilité au niveau indiqué sur l'affichage</li></ol>



---

## Boucle Installation

---

### NOUVELLE DALLE POUR

Ty-wrap 1-1/4 po en PVC tuyau vers le haut de la barre d'armature dans la taille et la configuration de la boucle (ex. 4 « x 8 »). Alors ty-envelopper la boucle vers le haut du châssis en PVC. Cela stabilise la boucle lors de la coulée et la sépare de l'armature.

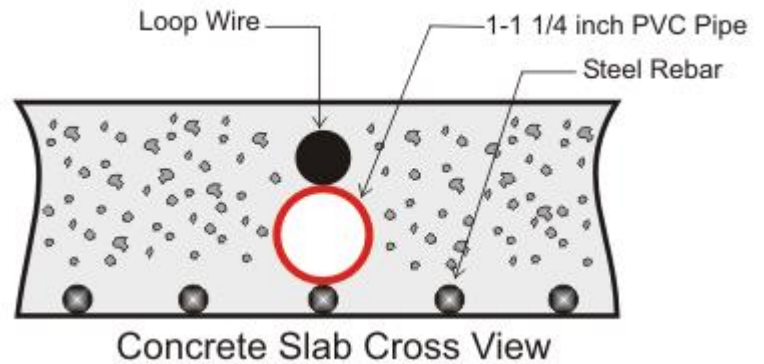

---

### SVU LA SURFACE EXISTANTE DE LA COUPE

Couper 1" profondément dans la surface existante, placer une coupe dans les coins pour éviter les bords tranchants d'endommager le fil de la boucle de 45°. Encocher pour la connexion « T » où le câble est connecté à la boucle. Retirer tous les débris de la coupe finie avec l'air comprimé. Placez la boucle dans la coupe de la scie. Placer le matériau de backer dans la scie entaille au dessus de la boucle et le pack étroitement. Placez un scellant de qualité sur la scie coupe afin de sceller la surface.

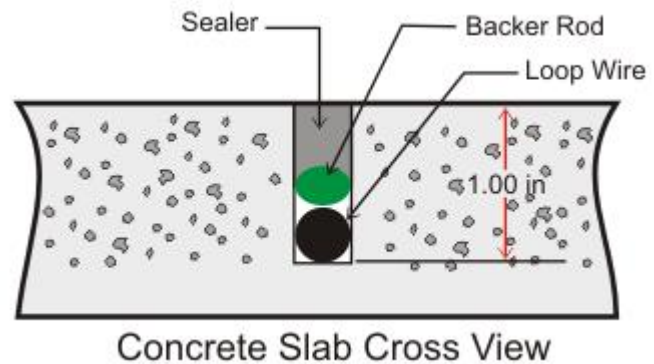

---

### REFAIRE SURFACE ASPHALTE

Scie à découper la surface existante 3/4" de profondeur et place un 45° couper dans les coins pour éviter les bords tranchants d'endommager le fil de la boucle. Retirer tous les débris de la coupe finie avec l'air comprimé. Placez sable sur le fil en boucle à la surface et le pack étroitement. Poser le nouvel asphalte

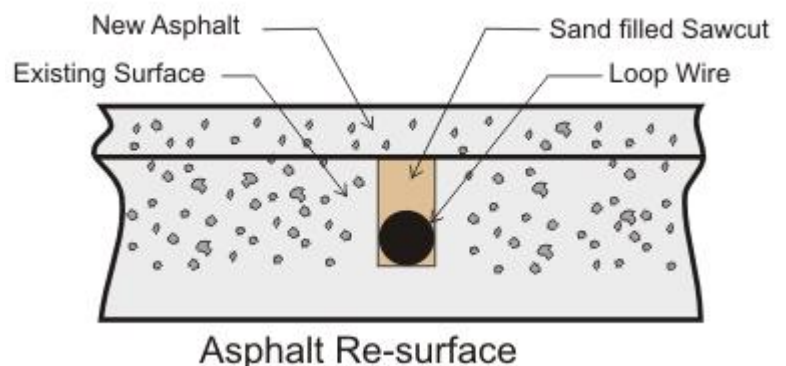

---

### Directives d'Installation générale

- Utilisez des boucles EMX Lite préformé pour des installations rapides, fiables et conformité CE.
- L Câble (fil détecteur de boucle) doit être tordu un minimum de 6 tours / pied pour éviter les effets de bruit ou d'autres interférences.
- Hauteur de détection est d'environ 70 % du côté le plus court de la boucle. Exemple : hauteur de détection pour une boucle de 4 « x 8 » =  $48 \text{ "x} .7 = 33,6 \text{ "}$

---

## Informations de commande

---

ULT-PLG ULTRALOOP véhicule détecteur de boucle

---

## Accessories

---

PR-XX EMX Lite préformé Loops™

---

## Garantie

---

### **WARRANTY**

**EMX Industries Incorporated warrants all products to be free of defects in materials and workmanship for a period of two years under normal use and service from the date of sale to our customer. This warranty does not cover normal wear and tear, abuse, misuse, overloading, altered products, damage caused by incorrect connections, lightning damage, or use other than intended design.**

**There is no warranty of merchantability. There are no warranties expressed or implied or any affirmation of fact or representation except as set forth herein.**

**EMX Industries Inc. sole responsibility and liability, and the purchaser's exclusive remedy shall be limited to the repair or replacement at EMX Industries option of a part or parts found not conforming to the warranty. In no event shall EMX Industries Inc. be liable for damages of any nature, including incidental or consequential damages, including but not limited to damages resulting from non-conformity, defect in material or workmanship.**

*effective date January 1, 2002*



BLANK PAGE

BLANK PAGE



4564 Johnston Parkway  
Cleveland, Ohio 44128  
United States of America  
[www.emxinc.com](http://www.emxinc.com)

Technical Support: (216) 834-0761  
[technical@emxinc.com](mailto:technical@emxinc.com)

Sales: (216) 518-9888  
Fax: (216) 518-9884  
[salesupport@emxinc.com](mailto:salesupport@emxinc.com)

